

VIVOTEK

A Delta Group Company

User Manual

Network Video Recorder

ND9442P/9542P

ND9326P/9426P

Revision History

Document Version	Release Date	Change Description
2.0	2025-08-30	Complete rewrite for firmware 5.0 Applied new manual layout
2.1	2025-12-09	Revision based on firmware 5.1

Table of Contents

1 Introduction	P9
Overview of the Core+ AI Series NVRs	
Core Features	
System Specifications	
Software Compatibility	
2 Getting Started	P11
Locating and Identifying the NVR (See Appendix C)	
Initial Setup and Configuration	
Logging In to the NVR	
Reset Password	
Steps to Reset a Password	
Additional Scenario: Verification via QR Code	
System Overview	
Navigation Panel	
Header Bar	
Main Display Area	
3 Live	P27
Accessing Live View	
Local Console	
Web Interface	
Viewing Modes	
Local Console	
Web Interface	

Layout Management

Local Console

Web Interface

Controlling Individual Camera Feeds

Local Console

Web Interface

4 Playback

P38

Accessing Playback

Camera and Time Selection

Selecting Cameras

Selecting a Date and Time

Playback Controls and Event Tags

Playback Controls

Camera Control Bar

Event Tags and Timeline

Exporting Recorded Footage

Local Console

Web Interface

5 Search

P48

Alarm Search

Setting Search Criteria

Viewing Search Results

Exporting Alarm Search Results

Smart VCA Event Search

Setting Search Criteria

Viewing Search Results

Exporting Smart VCA Event Search Results

Trend Micro IoT Security Search

Setting Search Criteria

Viewing Search Results

Exporting Trend Micro IoT Security Search Results

Bookmark Search

Setting Search Criteria

Viewing Search Results

Exporting Bookmark Search Results

6 AI

P60

Accessing AI

Using Smart Search II

Setting Search Parameters

Viewing and Managing Results

Using Deep Search

Setting Search Parameters

Viewing and Managing Results

7 Cameras

P70

Management

Viewing Camera List and Status

Camera Add/Edit

Network

Camera Network Settings

Media

Video

Audio

Image

Display

Image Settings

Scheduling Options

Exposure

Focus

Privacy Mask

Lens

Smart VCA Detection

Rule List

Detection Types

Detection Configuration

IR Illuminator Bidirectional Detection and Activation

Configuring Motion Detection

PTZ Settings

Configuring PTZ Presets

Configuring Patrol Sequences

Port Forwarding

Camera List

External Port

Router Setup

Update Firmware

Update via Cloud

Manual Update

Batch Upload

Apply to Matching Cameras

8 System

P108

Device

Information

Language & Time

Display

Multiple Display

Storage

NVR Storage

Volume

Recording

Recording Option

Backup

Alarm

Alarm
Recipien
SMTP

Network

Network Settings
Security

Service

VORTEX Connect
VSS & iViewer Companion

PoE

PoE Status
PoE Configuration

User

User
Login & Timeout

Maintenance

System Maintenance
Logs & Support

9 Video Export (Local Only) P135

Configuring the Export

Disk Space Evaluation
Exporting Footage
Completion Status

Appendix P139

A. Physical Overview (ND9442P / ND9542P)

Chassis Dimensions
Front View
Rear View
Quick Installation Guide (ND9442P / ND9542P)
AM-612 Rack Mount Rail Installation

B. Physical Overview (ND9326P / ND9426P)

Chassis Dimensions

Front View

Rear View

Quick Installation Guide (ND9326P / ND9426P)

C. Using Device Manager and Shepherd

Using Device Manager to Locate and Identify NVR on the LAN

Using Shepherd to Locate and Identify NVRs on the LAN

D. Safety and Compliance

Safety Instructions

Regulatory Compliance

Licensing Notices

Introduction

This chapter provides a comprehensive introduction to the VIVOTEK Core+ AI Series Network Video Recorders (NVRs), covering the ND9326P, ND9426P, ND9442P, and ND9542P models. It outlines the purpose, shared capabilities, and system requirements that are common across these devices. It is intended to help users understand the capabilities of the NVR before proceeding to installation and operation.

Overview of the Core+ AI Series NVRs

The Network Video Recorder (NVR) is a centralized surveillance management system designed to record, store, and manage video streams from multiple IP cameras. It supports both local console operation and remote web access, providing flexibility for deployment in environments such as offices, retail stores, factories, and public facilities.

The system accommodates multiple high-definition video channels from VIVOTEK and third-party IP cameras through standard protocols. It integrates AI-powered analytics for advanced detection and classification, and provides intelligent search tools, such as Smart Search II and Deep Search, for rapid retrieval of recorded events. Recording can be scheduled or event-triggered, and video export tools are available for incident review and evidence preservation.

The Core+ AI Series includes models with varying channel capacities—8-ch (ND9326P), 16-ch (ND9426P, ND9442P), and 32-ch (ND9542P)—all featuring embedded PoE, AI-enhanced search capabilities, and high compatibility with multiple camera brands.

Core Features

The NVR series provides powerful AI-driven functions for efficient surveillance operations:

Multi-channel High-Definition Recording

Support a wide range of IP cameras with H.264/H.265/MJPEG formats, enabling up to 4K local video output for high-detail monitoring.

Core+ AI Deep Search

Leverage metadata from Vision Object Analytics-enabled cameras; Attribute Search and Scene Search enable rapid identification of people or vehicles based on attributes such as gender, clothing, or vehicle type.

Smart VCA Event Search

Support searching, playback, and export of event-triggered recordings from Smart VCA-enabled cameras.

Embedded PoE and RAID Storage

Integrate 802.3at/af PoE ports (with PoE management on select models) for simplified wiring. ND9442P and ND9542P also support RAID 0/1/5 for enhanced data protection.

Cybersecurity Measures

Incorporate Trend Micro IoT Security to enhance device security.

Versatile Display and Usability

Equip with HDMI and VGA outputs, support multi-layout live viewing (1×1 to matrix formats) across dual monitors, and include watchdog and auto-restart after power recovery.

System Specifications

Item	Details
Operating Environment	Embedded Linux with hardware/software watchdog; auto-restart after power recovery (Embedded PoE assumes stable ambient conditions)
Channel Count	8 (ND9326P), 16 (ND9426P, ND9442P), 32 (ND9542P)
PoE Support	802.3af/at PoE; PoE management in ND9442P and ND9542P
Search & Analytics	Core+ AI Deep Search (Attribute & Scene) and Smart VCA Event Search
RAID	RAID 0/1/5 support on ND9442P and ND9542P
Cybersecurity	Trend Micro IoT Security on ND9442P and ND9542P
Display Output	HDMI & VGA, up to 4K; multi-layout live viewing
Storage	Internal SATA Bay Support (up to 4 drives; varies by model)
Cloud Integration	VORTEX / VAST platform; VIVOCLOUD discontinued since firmware v4.8
Application Scenarios	Corporate, retail, industrial, and public spaces requiring advanced AI-enhanced surveillance

Software Compatibility

Item	Details
Supported Browsers	<ul style="list-style-type: none"> • Chrome
Browser Limitations	Safari does not support Snapshot and Auto Screen Ratio
Supported OS	<ul style="list-style-type: none"> • Windows 7 (64-bit) • Windows 10
Minimum PC Requirements	<ul style="list-style-type: none"> • CPU: Intel i5 (4th generation or higher) • RAM: 4 GB or higher

Getting Started

This chapter provides the basic steps required to prepare the NVR for first-time operation.

The following sections describe how to locate the device on the network, complete the initial setup, log in, and become familiar with the main interface.

These instructions are intended as a quick start reference, while advanced configuration details are presented in later chapters and in the appendices.

Locating and Identifying the NVR (See Appendix C)

For local management, connect the NVR to a monitor using HDMI or VGA, and ensure that the unit is powered on and connected to the network.

Once these connections are in place, the local interface is displayed directly on the monitor without the need for additional discovery tools.

For management through a web browser, the NVR must first be located on the network. The supplied utilities—**Device Manager** and **Shepherd**—scan the local network segment and list all detected VIVOTEK devices together with their model names, IP addresses, and status.

After the NVR appears in the list, confirm its model and IP address before accessing it through a web browser.

Status	Model	Host Name	IP	MAC	Firmware
Unauthorized	ND9542P		10.42.2.33	0002D1A35CDF	5.0.0.5
Unreachable	ND9326P		10.42.2.119	0002D1AAAFB2	4.6.0.6.v0711

Detailed procedures for using Device Manager and Shepherd are provided in **Appendix C: Using Device Manager and Shepherd**.

Initial Setup and Configuration

When the NVR is powered on for the first time, a series of setup screens will appear to complete the initial configuration. This configuration process includes the following steps:

1. Name & Language

Specify a device host name and select the preferred interface language.

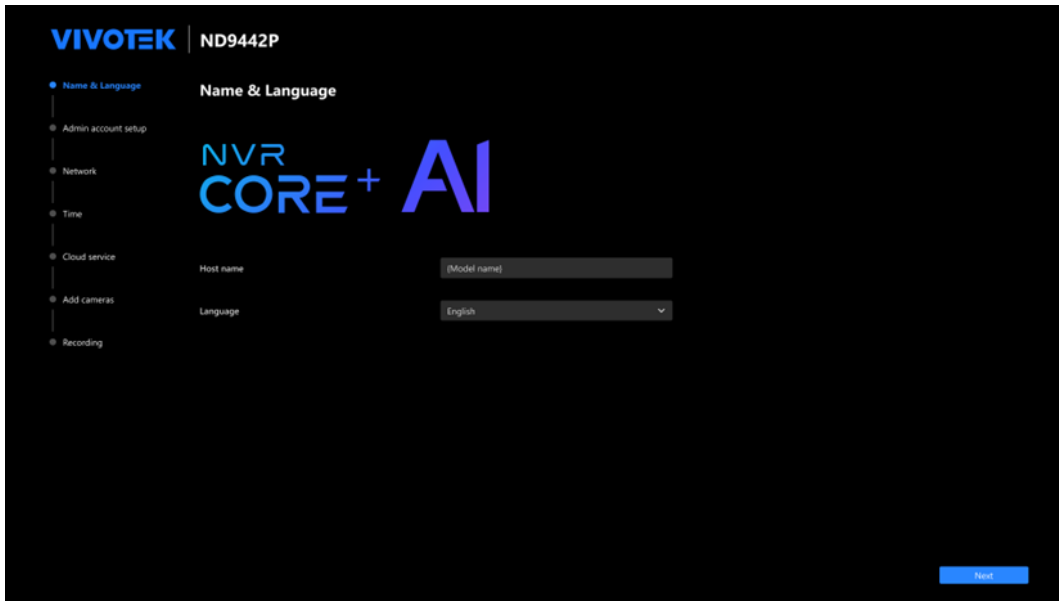

The screenshot shows the 'Name & Language' configuration page for a VIVOTEK ND9442P device. The page features a sidebar with navigation options: Name & Language (selected), Admin account setup, Network, Time, Cloud service, Add cameras, and Recording. The main content area is titled 'Name & Language' and displays the device logo 'NVR CORE+ AI'. Below the logo, there are two input fields: 'Host name' with a placeholder '(Model name)' and 'Language' with a dropdown menu set to 'English'. A blue 'Next' button is located at the bottom right of the page.

2. Admin account setup

Create an administrator password to protect system access. An email address is also required, which will be used to receive verification codes during password-reset procedures.

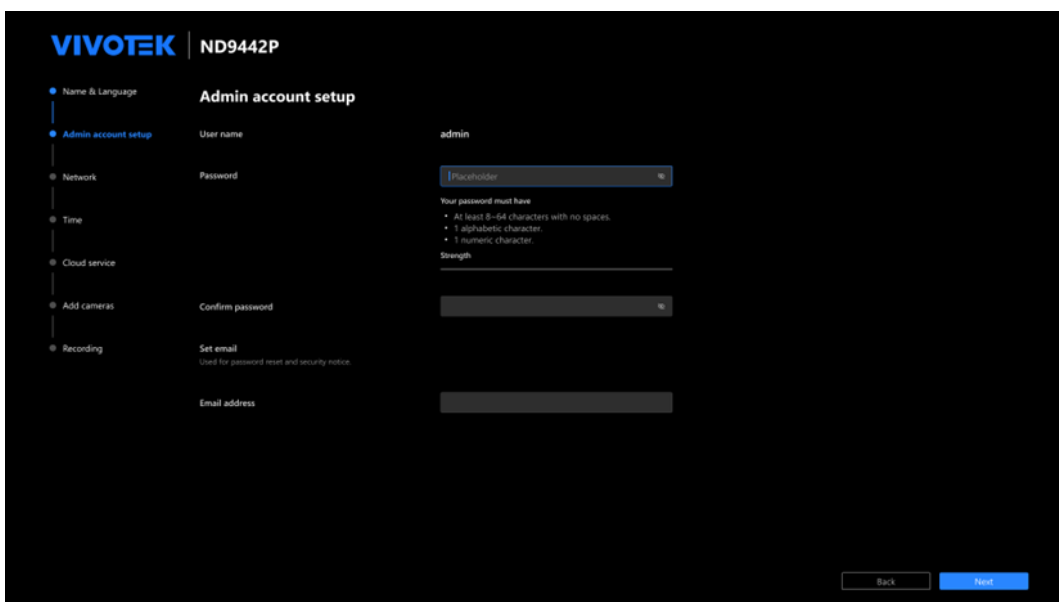

The screenshot shows the 'Admin account setup' configuration page for a VIVOTEK ND9442P device. The page features a sidebar with navigation options: Name & Language, Admin account setup (selected), Network, Time, Cloud service, Add cameras, and Recording. The main content area is titled 'Admin account setup' and contains the following fields: 'User name' with the value 'admin', 'Password' with a placeholder '[Placeholder]' and a strength indicator, 'Confirm password' with a placeholder, and 'Set email' with a sub-label 'Used for password reset and security notice' and an 'Email address' field. The password strength indicator shows requirements: 'Your password must have' followed by a list: 'At least 8-64 characters with no spaces', '1 alphabetic character', and '1 numeric character'. A 'Back' button and a blue 'Next' button are located at the bottom right of the page.

3. Network

Confirm the network connection. Select NET1 or NET2 (with PoE) as needed, and choose whether to obtain an IP address automatically (DHCP) or configure it manually.

VIVOTEK ND9442P

Network

Default gateway: NET 1 NET 2 (with PoE)

NET 1

IPv4 **Configuration**: Manual setup

IP: 10.10.10.10

Subnet mask: 255.255.128.0

Gateway: 10.10.10.10

DNS server 1: 10.135.101.51

DNS server 2: 10.135.1.51

IPv6 **Link local address**: fe80::202:d1ff:feaa:afe4 / 64

IPv6 **Configuration**: Manual setup

IPv6 **IP / Prefix length**: aaaa:aaaa:aaaa:aaaa::aaaa:aaaa

Buttons: Back, Next

4. Time

Specify the date, time, and time zone. The system can synchronize with an NTP server or use manual input.

VIVOTEK ND9442P

Time

Set date and time: Auto

NTP server: NTP server Custom NTP server

NTP server: Worldwide (pool.ntp.org)

Time zone: America / Los Angeles (PST, GMT-8:00)

Buttons: Back, Next

5. Cloud Service

If the NVR is connected to the Internet, an option to link the device to VORTEX Connect will be available. This step can be completed immediately or skipped for later configuration.

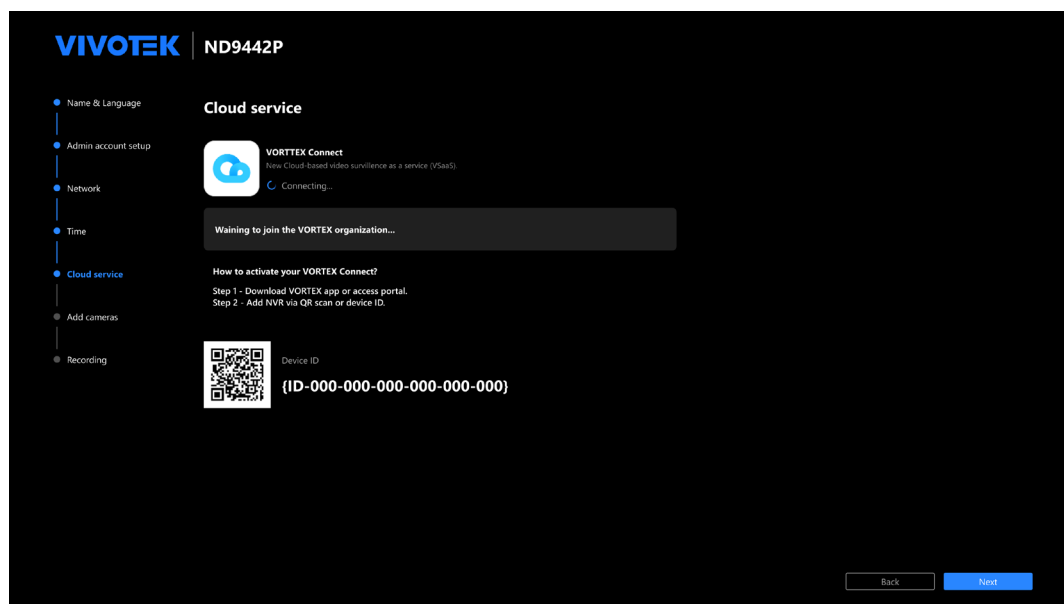

For Existing VORTEX Users:

1. Sign in to the VORTEX app.
2. Tap **Add Devices**.
3. Use the mobile device to scan the QR code displayed on the NVR.
4. Tap **Add**, then **Done**.

For New VORTEX Users:

1. Download the VORTEX app from the App Store or Google Play.
2. Tap **Create Account**, then enter an email address and password.
3. Confirm the email address to activate the account.
4. Create an organization name as prompted.
5. After the account is set up, follow the steps under "Existing VORTEX Users" to add the NVR.

(For detailed onboarding guide, please refer to: <https://vivotek.zendesk.com/hc/en-001/articles/43362643286169--VORTEX-Getting-Started-VIVOTEK-NVR-Onboarding-Guide>)

6. Add Cameras

The NVR scans the local network and displays available cameras. Select the cameras to add and provide authentication credentials for those that require access authorization.

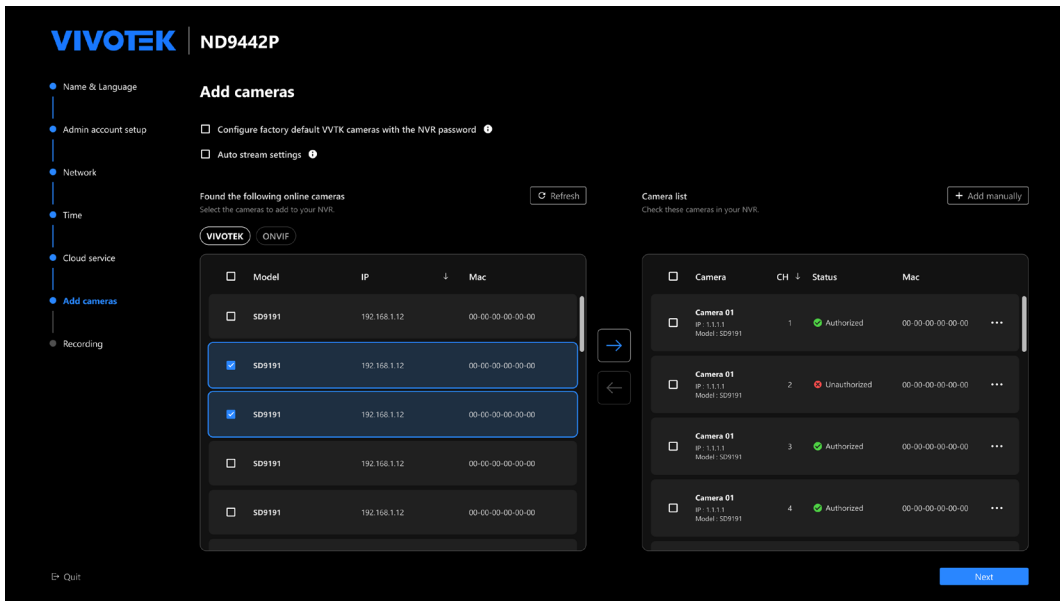

7. Recording

Create a storage volume from the installed disks for video recording.

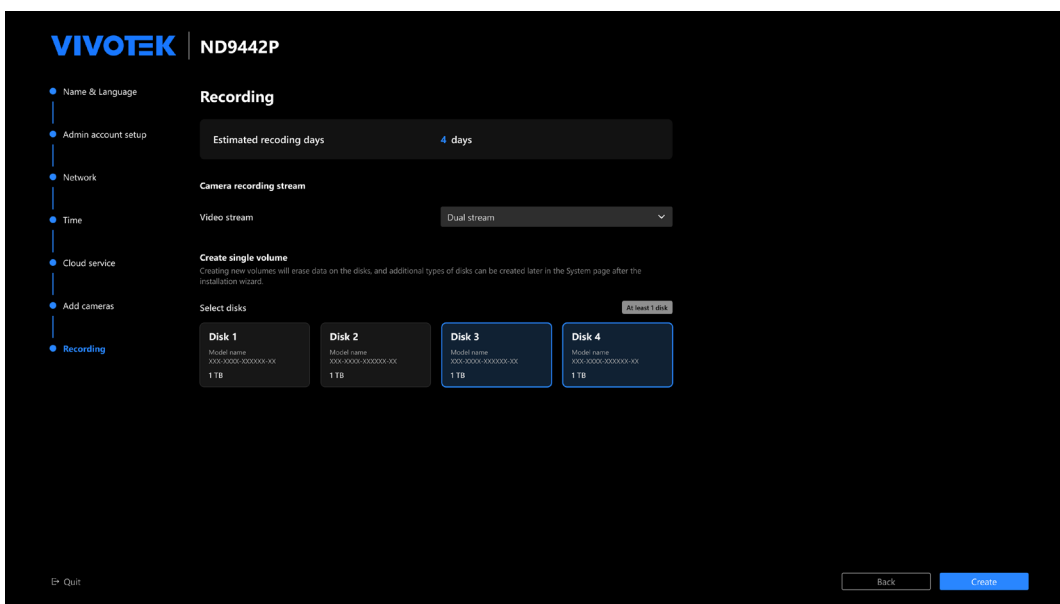

Once these steps are completed, the NVR is ready for live monitoring and recording. All settings can be reviewed and modified later through the system menus.

Logging In to the NVR

After the initial configuration is complete, the NVR can be accessed through either the local console or a web browser.

To log in from the **local console**:

1. Connect a monitor to the NVR and ensure the device is powered on.
2. The login behavior depends on the setting **Show login screen before viewing live video** under **Login & Timeout**.

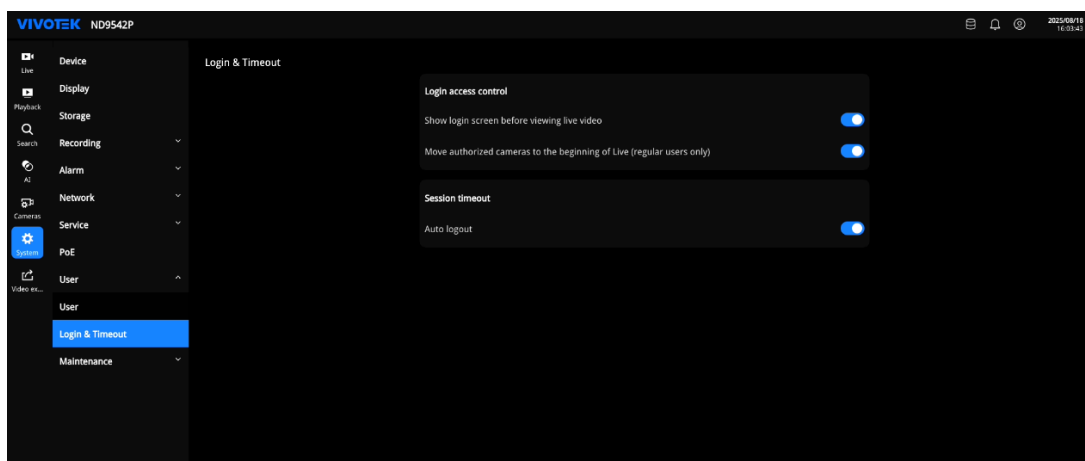

If this option is disabled, the system will display the Live View screen first. A login window will appear only when performing other operations. Basic actions within the Live View screen, such as switching between camera views, can be performed without authentication.

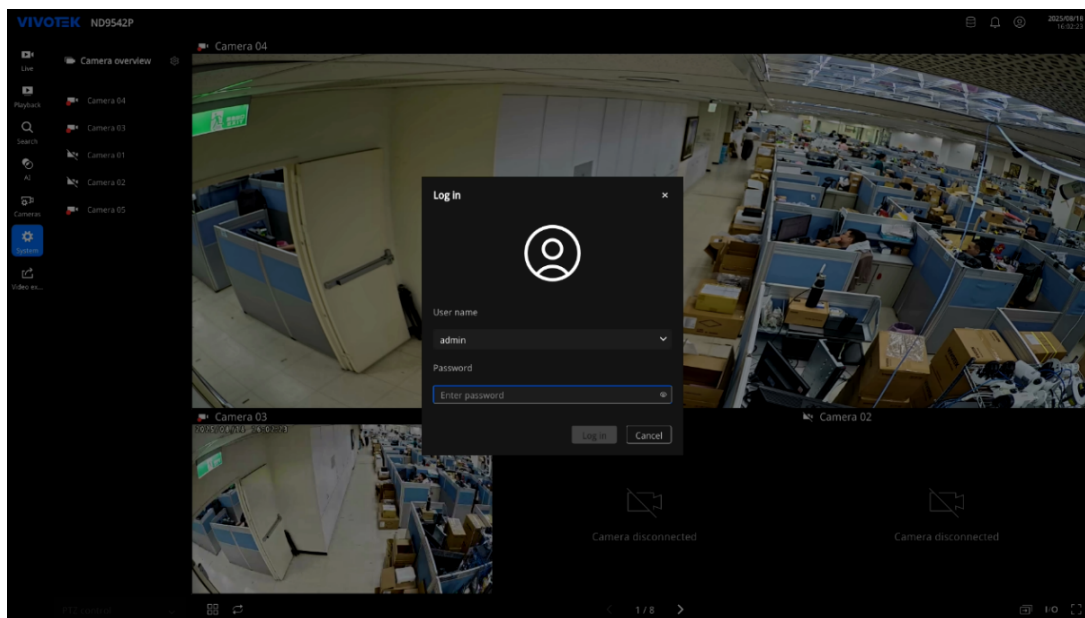

If this option is enabled, the system will display a full login screen immediately after startup. Authentication with the administrator account and password set during initial setup is required before accessing any functions.

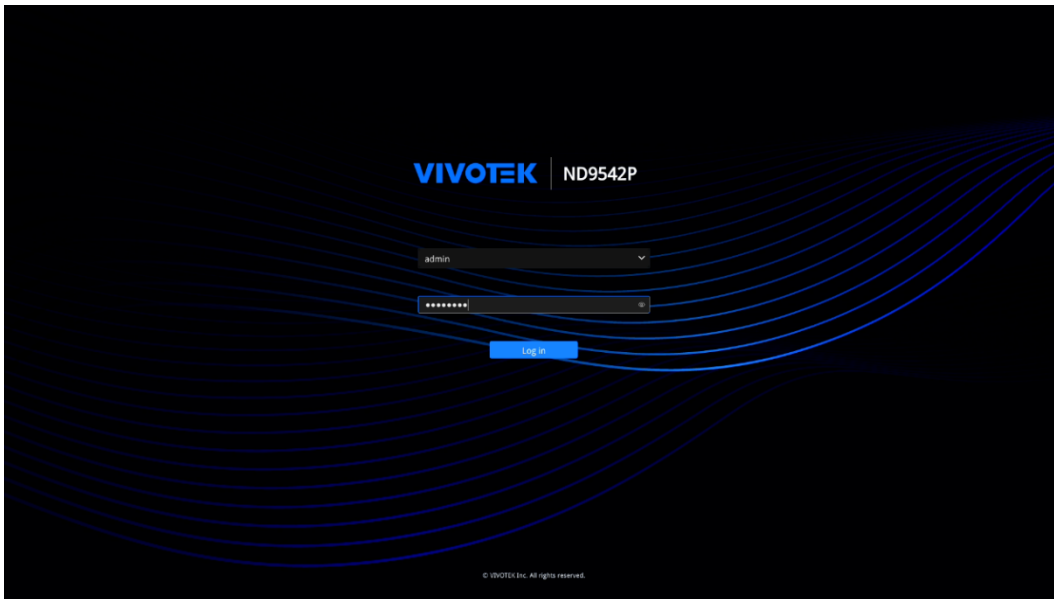

3. When the login window appears, enter the administrator account and password set during initial setup to continue.

To log in from a **web browser**:

1. Make sure the NVR is connected to the network and its IP address has been identified.
2. On a PC that is on the same network, open a supported web browser (Google Chrome is recommended).
3. Enter the NVR's IP address in the address bar to open the login page.
4. Enter the administrator account and password, then confirm to log in.

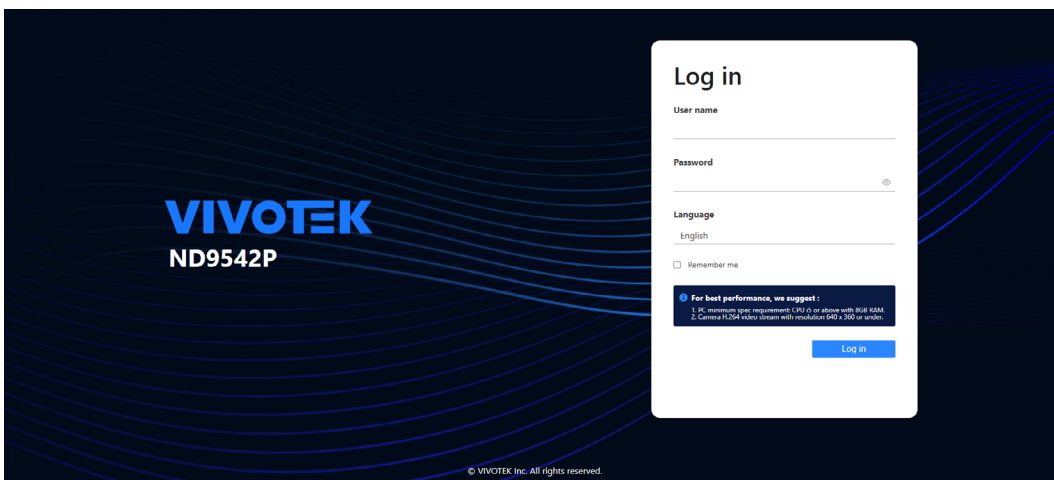

5. After logging in, the system opens in Live View mode. The options in the left-side navigation panel can be used to switch between Live, Playback, Search, AI, Cameras, and System.

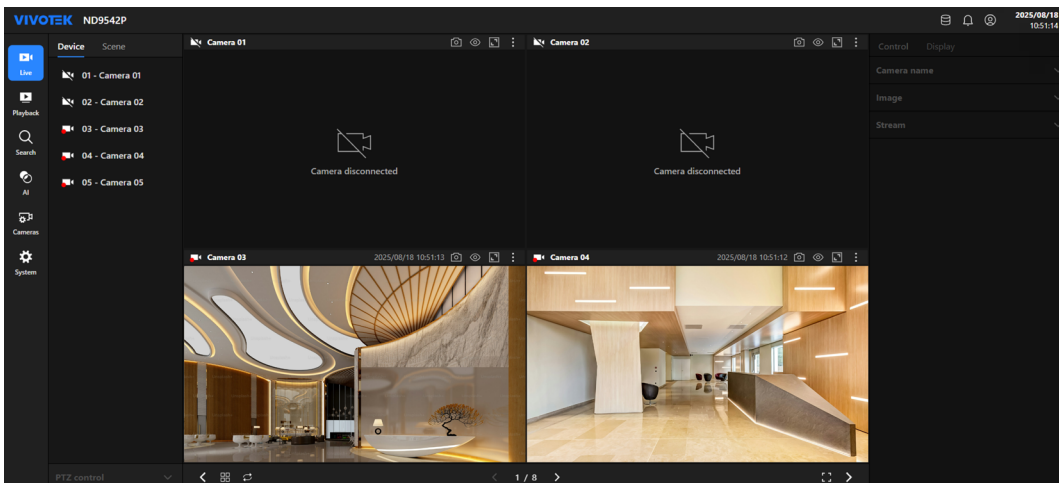

Reset Password

The NVR supports password reset through the local console and web interface. This function is available only to users with the **Admin** role. Before a password can be reset, the following conditions must be met:

- VORTEX Connect is enabled
- The NVR is added to an organization in VORTEX

Steps to Reset a Password

When an admin login attempt fails, the login screen displays a **Reset Password** button.

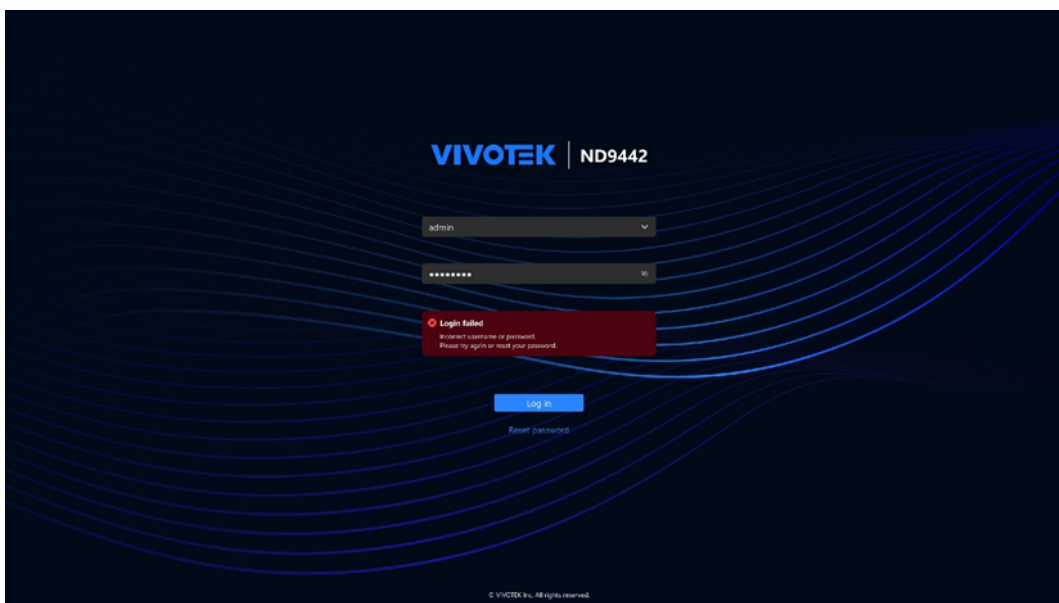

Local Console Interface

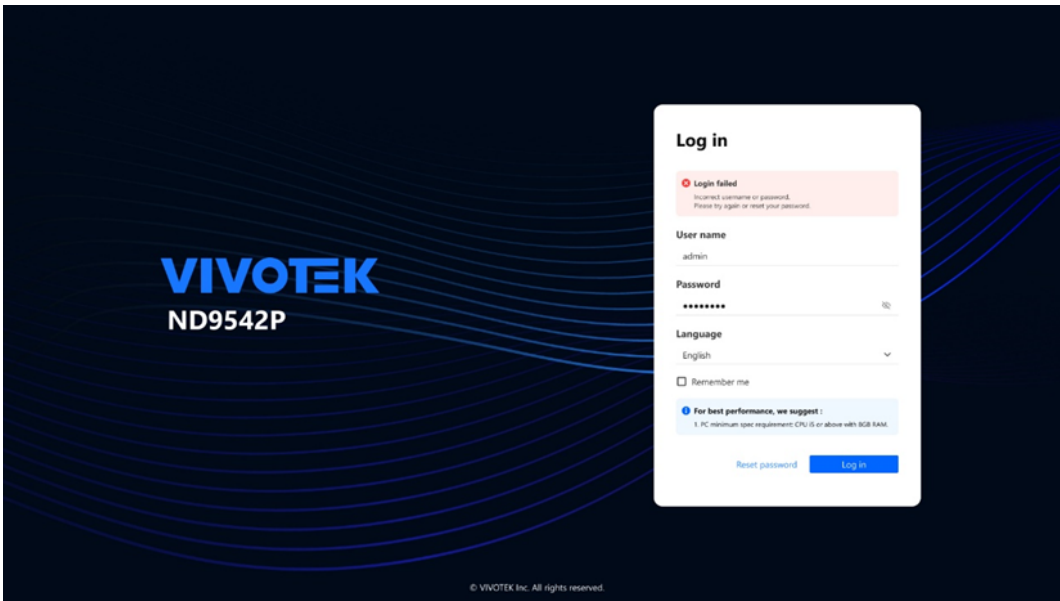

Web Interface

1. Click **"Reset Password."** The system sends a verification email to the administrator's registered email address.

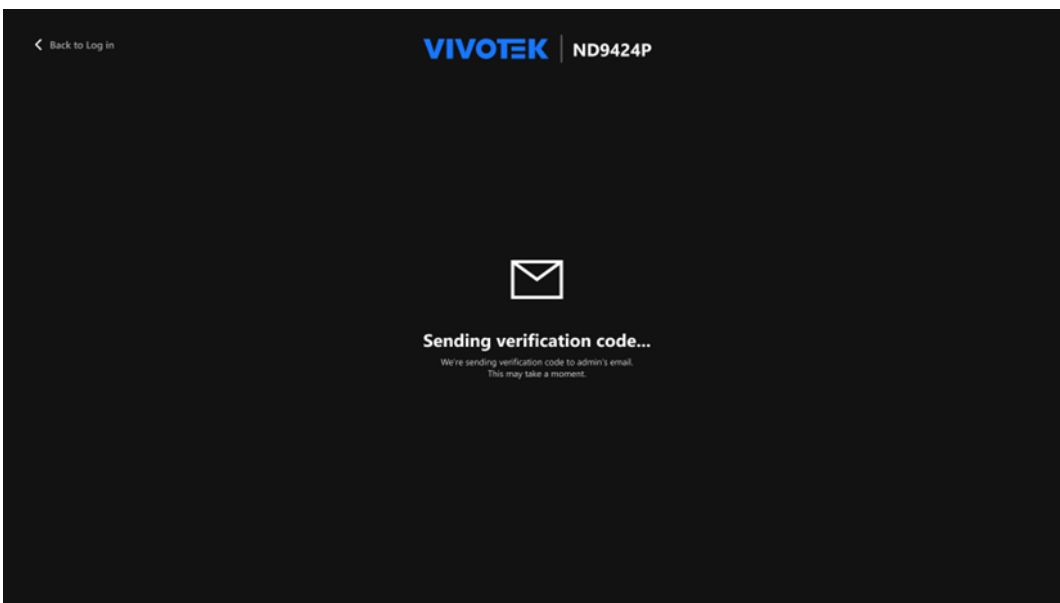

2. Retrieve the 6-digit verification code from the email.
3. Enter the 6-digit verification code.

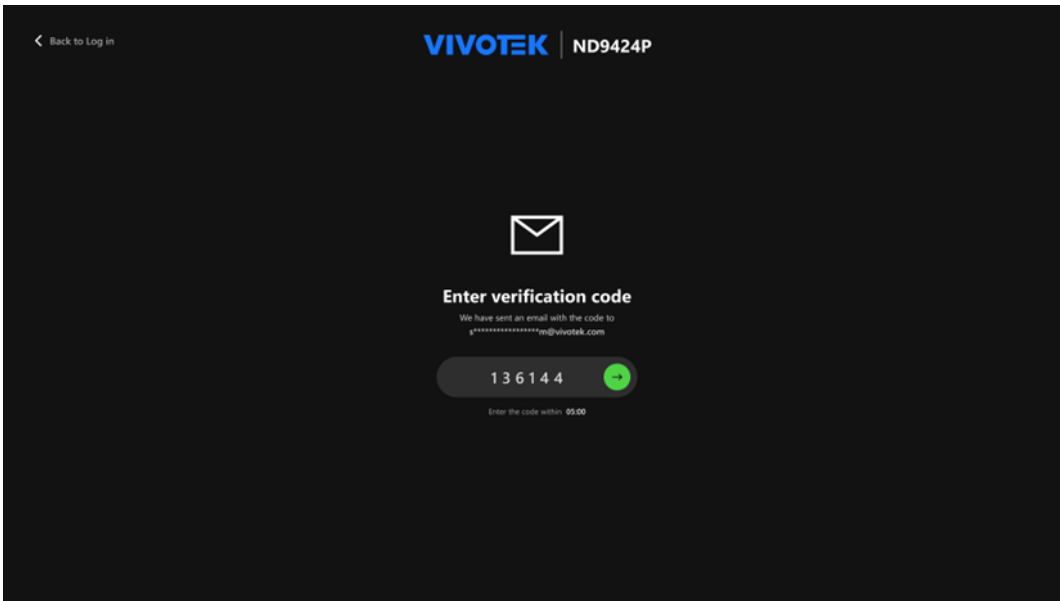

4. After the verification is verified, the Reset Password page appears. Enter the new password and confirm it.

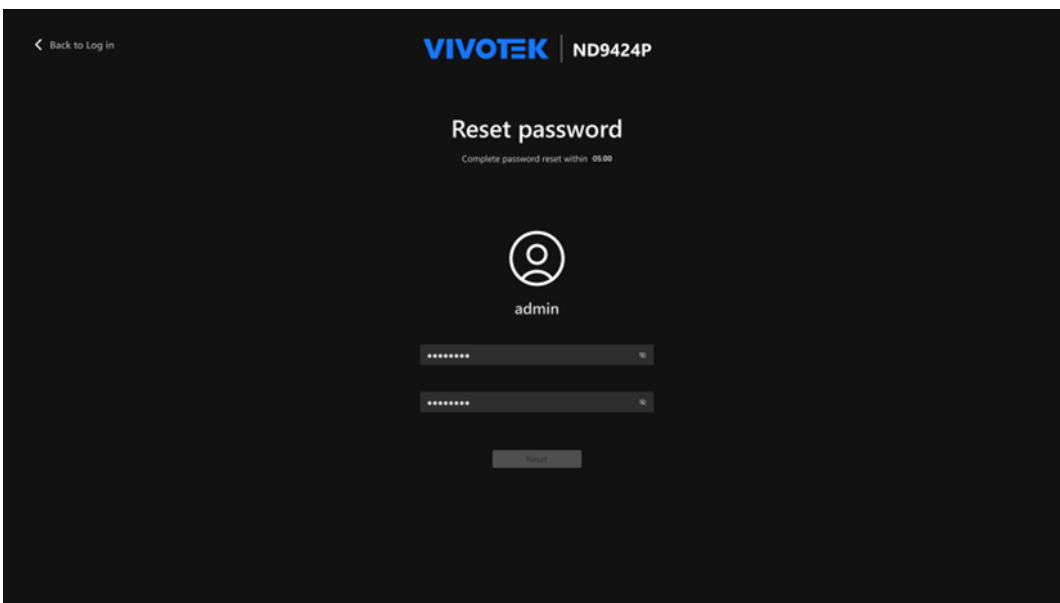

Additional Scenario: Verification via QR Code

If the system detects that the NVR cannot reach the Internet, a verification prompt titled **Get Verification Code** appears.

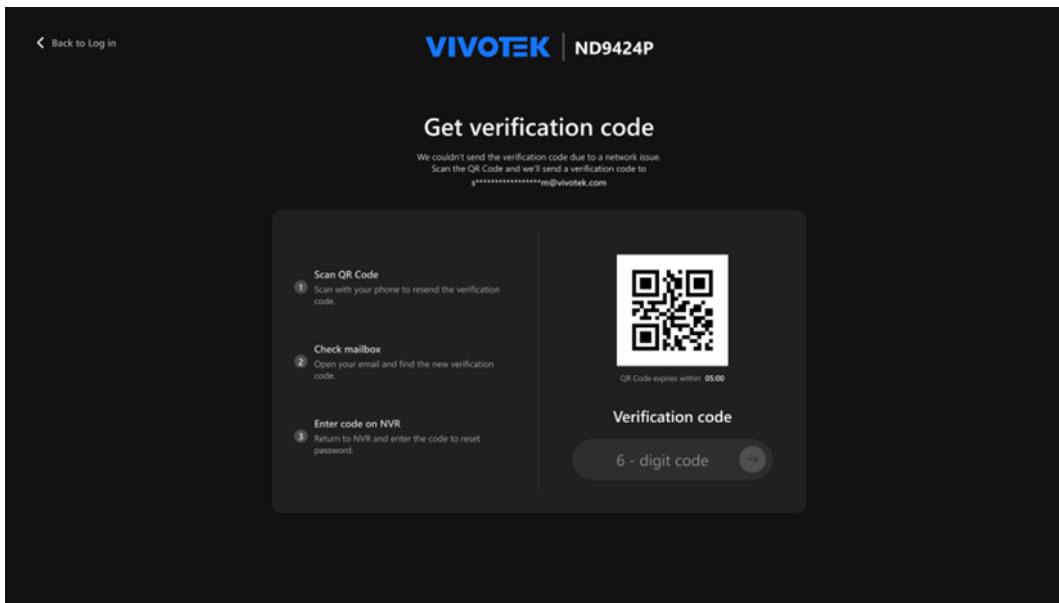

The screen displays a three-step instruction panel on the left and a QR code with an input field on the right.

1. Scan the displayed QR code with a mobile device.
2. A **Check your email** page appears on the mobile device, prompting the user to open the mailbox associated with the administrator account.

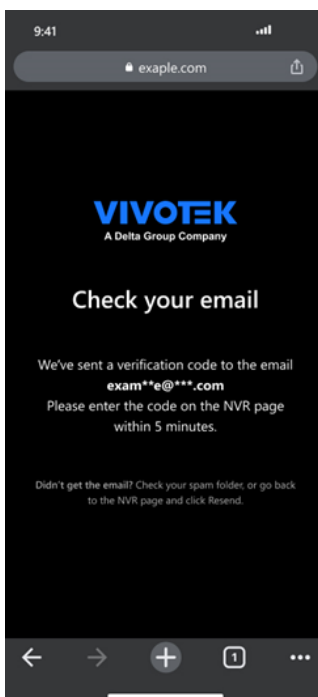

3. Retrieve the verification code from the email.
4. Enter the code into the field displayed on the NVR screen to proceed with the password reset process.

System Overview

The NVR interface is organized into three main sections: the navigation panel on the left, the header bar at the top, and the main display area in the center. These sections work together to provide access to live monitoring, video playback, search, system management, and other features.

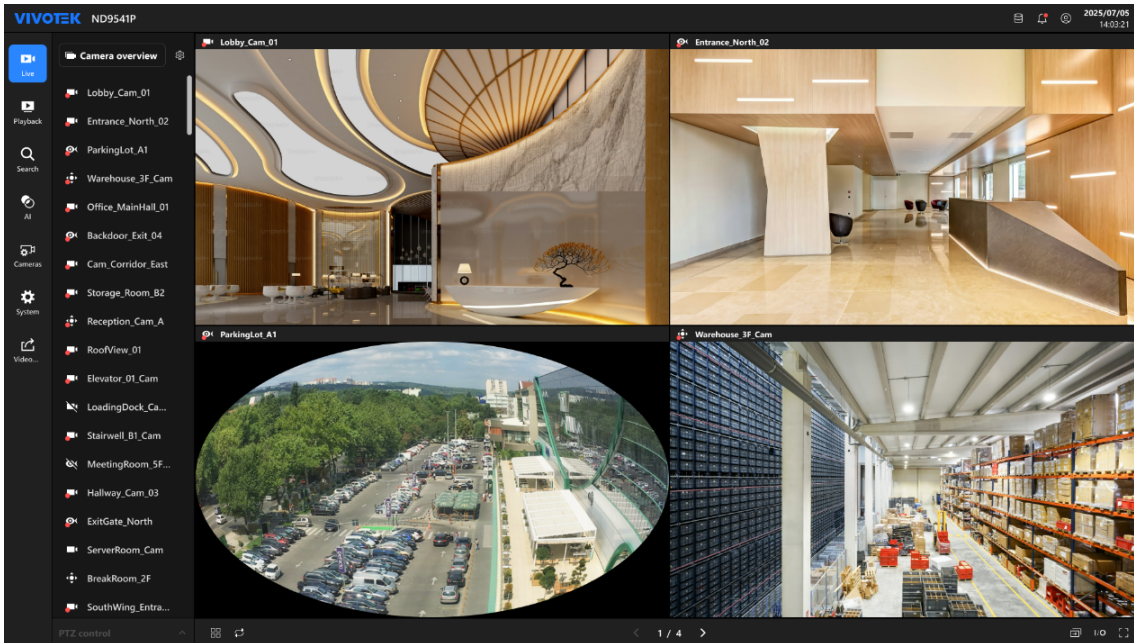

Local Console Interface

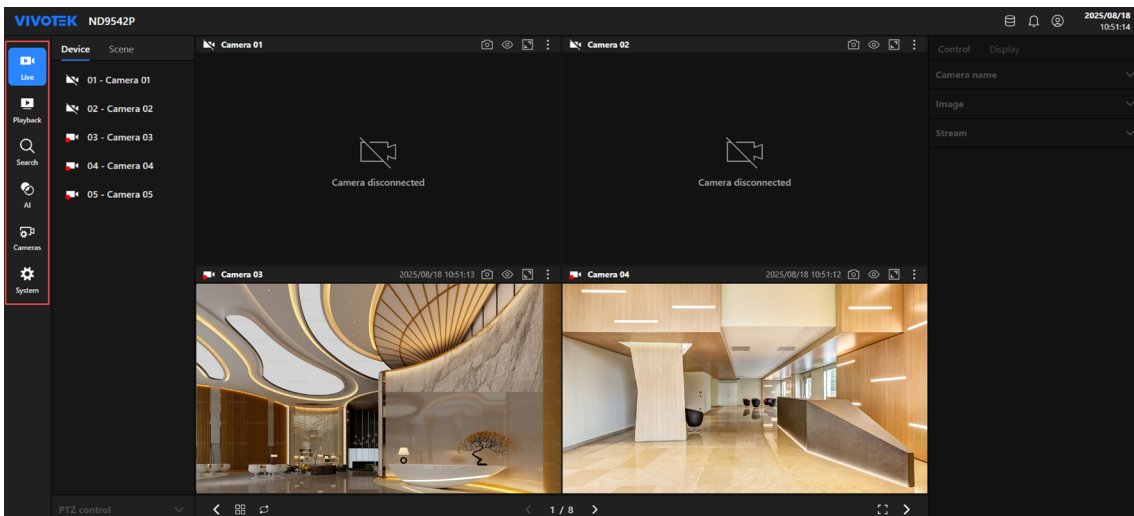

Web Interface

Navigation Panel

The navigation panel on the left provides quick access to major modules. On the local console, the panel includes **Live**, **Playback**, **Search**, **AI**, **Cameras**, **System** and an additional **Video Export** module at the bottom for exporting recorded video.

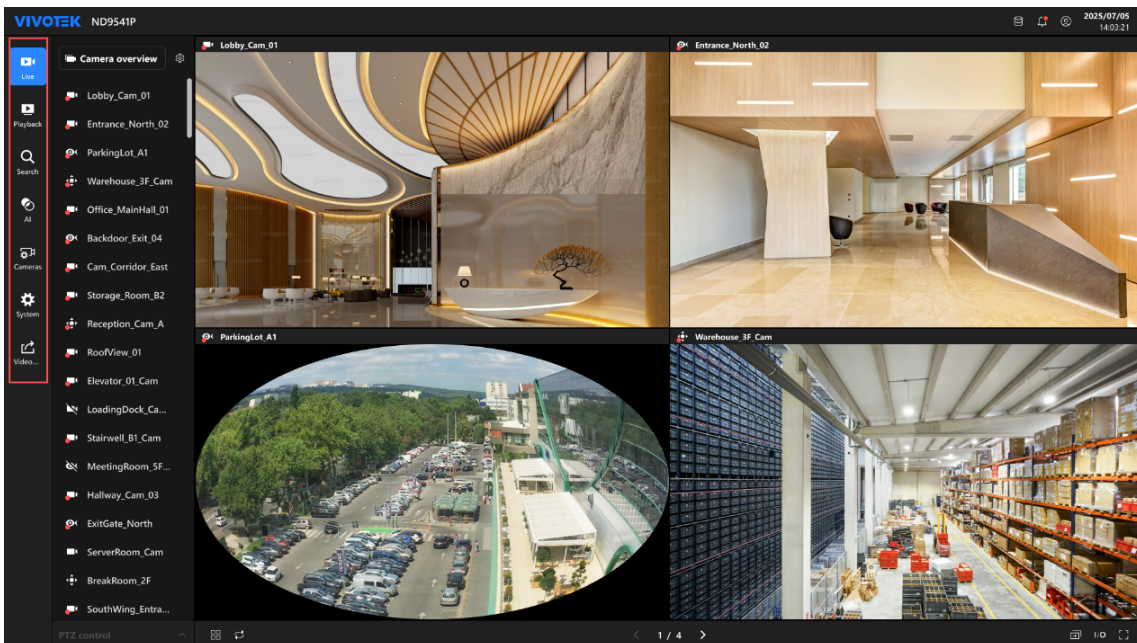

Local Console Interface

On the **web interface**, the **Video Export** module is not available.

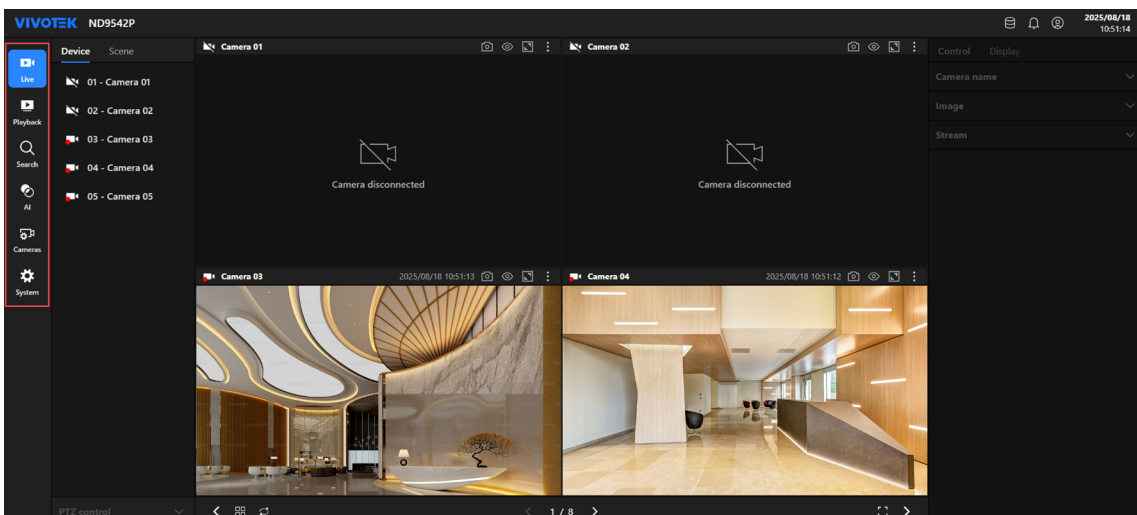

Web Interface

Selecting a module changes the content shown in the main display area.

Header Bar

The header bar, located at the top of the interface, provides quick access to key information and controls, including device identification, storage status, notifications, user account options, and the current date and time.



Host Name

At the top-left corner of the header bar shows the host name of the connected NVR. This name can be changed by going to **System > Maintenance**.

Storage Status

The storage icon  displays the current usage of the internal storage. Clicking this icon expands a panel beneath it that provides detailed information about used and available capacity. For more details and configuration options, click **Storage settings** in the panel to open the storage information page.

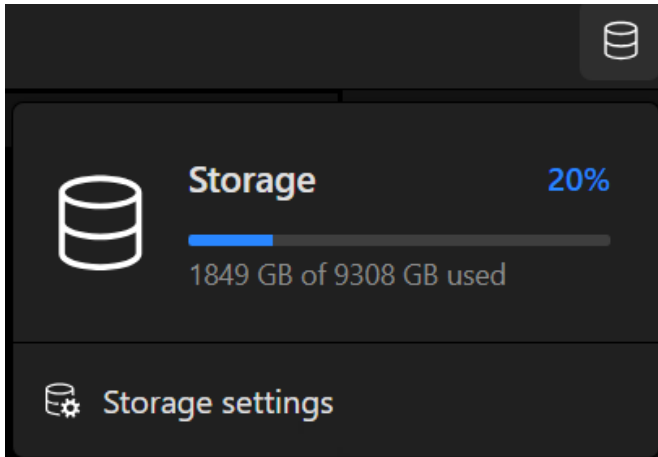

Notifications

The notification icon  displays system alerts and messages.

On the **local console**, when there are unread notifications, a red dot appears on the icon. Clicking the icon opens the **Search** module directly, regardless of whether there are notifications or not.

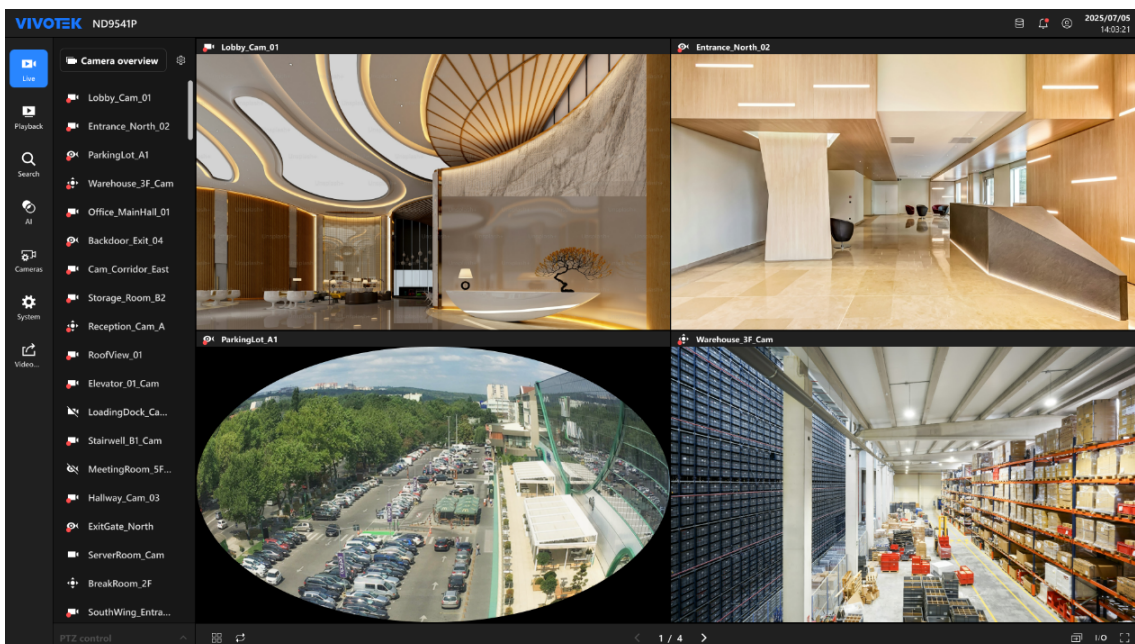

Local Console Interface

On the **web interface**, when there are unread notifications, a red number badge appears on the icon (showing 9+ if there are more than nine items). Clicking the icon expands a list of notifications, and selecting an item in the list opens the **Search** module.

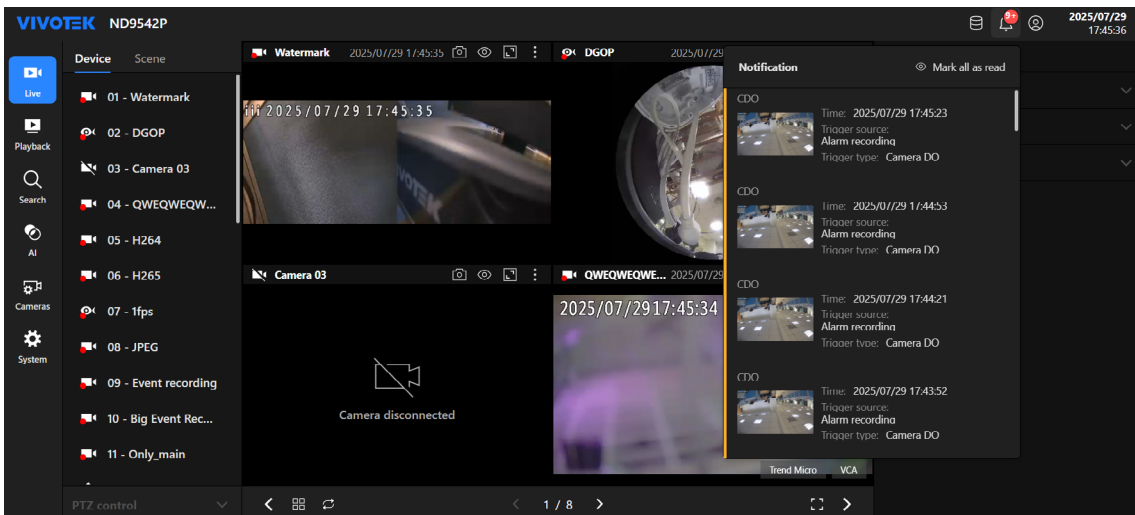

Web Interface

User Account

The user icon  provides access to account information and related actions. Selecting the icon expands a panel displaying the signed-in account name and role, along with the options **About**, **Reboot**, and **Logout**.

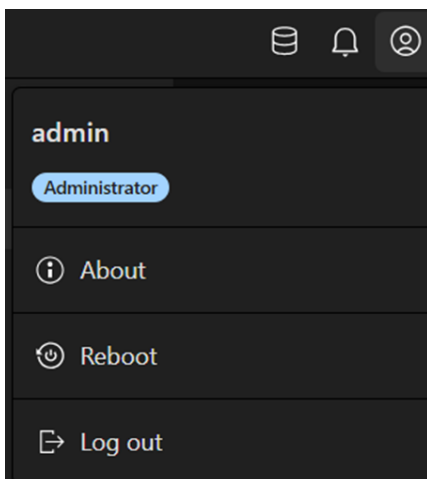

Selecting **About** opens the **About** window, which displays system information including the model name, firmware version, and device pack version.



Date and Time

Located at the far right of the header bar, this display shows the current date and time.



Main Display Area

The main display area shows content based on the selected module. For example, in **Live** mode, this area displays live video streams from the connected cameras, while in **Playback**, **Search**, and other modules, it shows recorded video, search results, or configuration options according to the selected function.

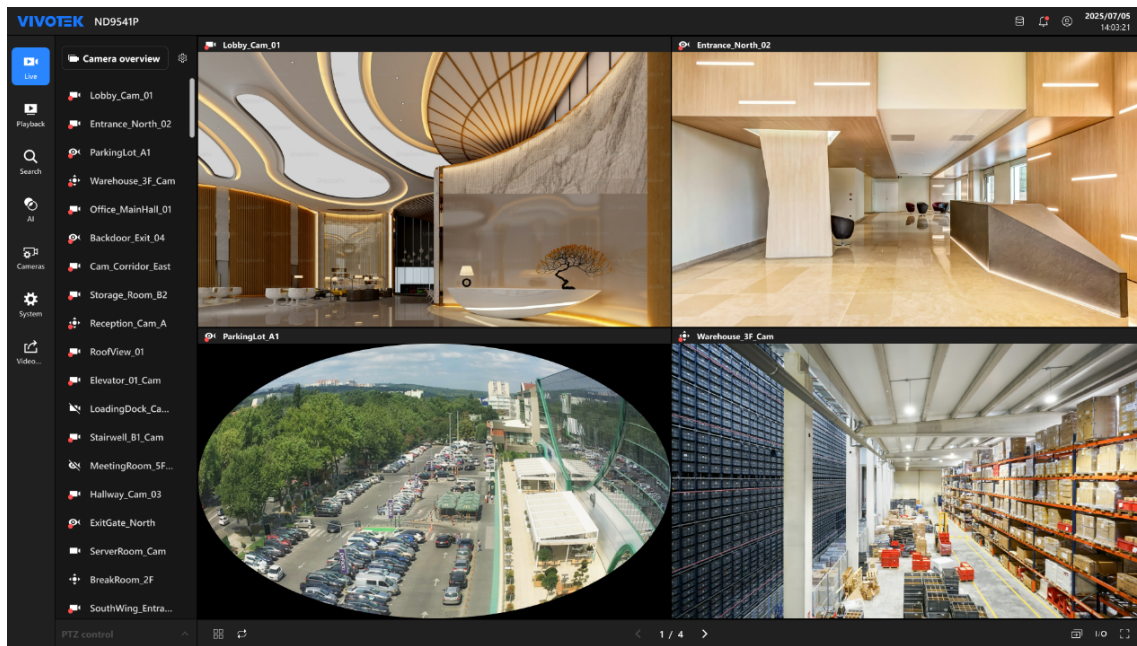

Live View on Local Console

The **Live** module provides centralized access to real-time video streams from all connected cameras. Operators can monitor surveillance footage, customize layouts, and interact with camera feeds using various control functions. On the web interface, it is also possible to switch between **Device** and **Scene** viewing modes for greater flexibility in organizing camera displays. This module is optimized for situational awareness and continuous observation, making it suitable for both small-scale deployments and large-scale surveillance operations.

The following sections describe how to enter the **Live** interface, manage camera layouts, and operate live monitoring features.

Accessing Live View

After logging in to the NVR, the system enters the Live interface by default. This module provides access to real-time video streams from all connected cameras, enabling operators to monitor ongoing activities, switch layouts, and interact with individual channels.

The layout and available features of the live view interface vary slightly between the **Local Console** and the **Web Interface**. The sections below describe each version in detail.

Local Console

The local interface is optimized for immediate on-site monitoring using a mouse, keyboard, and connected display.

The local interface is divided into three main sections:

- **Left panel** – Lists all connected cameras under “Camera overview.” When a PTZ-capable camera is selected, the **PTZ control** panel appears below the camera list.
- **Central viewing area** – Displays the live video streams of all connected cameras, arranged according to the selected layout. When the number of cameras exceeds the display capacity, additional pages can be accessed through pagination controls.
- **Bottom toolbar** – Provides layout selection, view rotation, page navigation, main/sub screen switching, DIDO (Digital Input/Output) access, and full-screen mode.

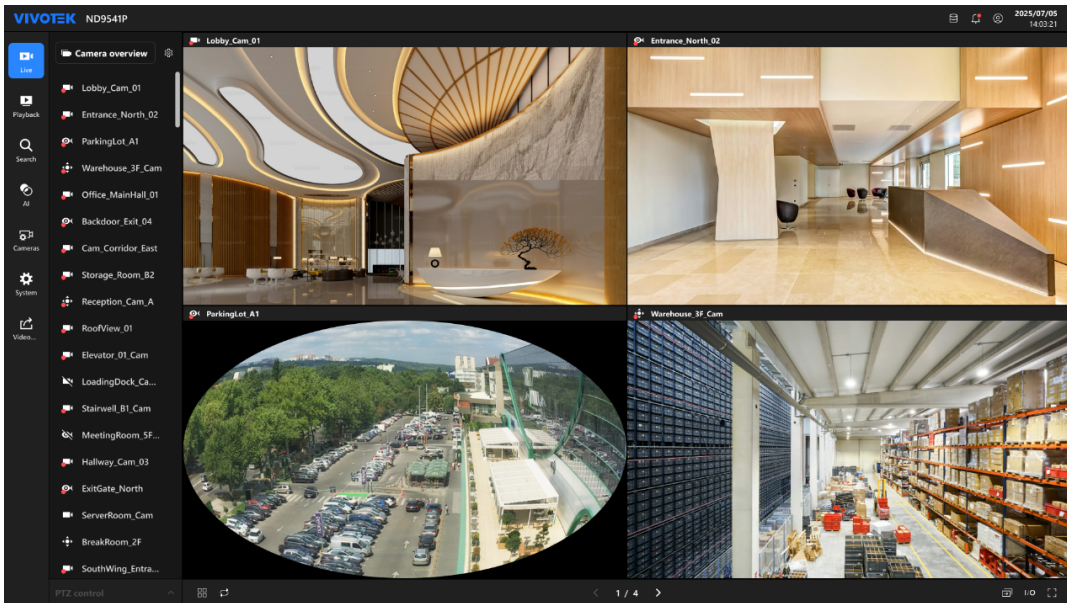

Live View on Local Console

Web Interface

The web interface is designed for remote access and offers additional layout flexibility, including **Device** and **Scene** modes.

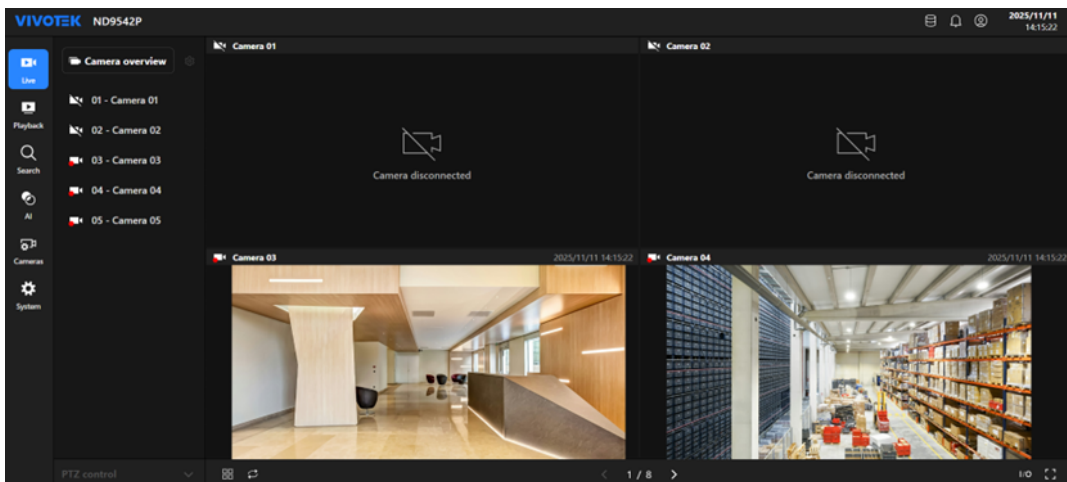

Live View on Web Interface

The web interface is divided into three main sections:

- **Left panel** – Allows switching between **Device** and **Scene** tabs. When a PTZ-capable camera is selected, the **PTZ control** panel appears below the camera list.
- **Central viewing area** – Displays the live video streams of all connected cameras, arranged according to the selected layout. When the number of cameras exceeds the display capacity, additional pages can be accessed through pagination controls.
- **Bottom toolbar** – Provides page navigation, layout switching, full-screen mode, and additional stream-related options depending on the system version.

Viewing Modes

The **Live** module provides different ways to organize and display camera channels. The local console uses a fixed default camera list, while the web interface supports both a default list and custom scenes for flexible viewing.

Local Console

The local console displays cameras in the **default camera list view**, which functions similarly to Device mode on the web interface.

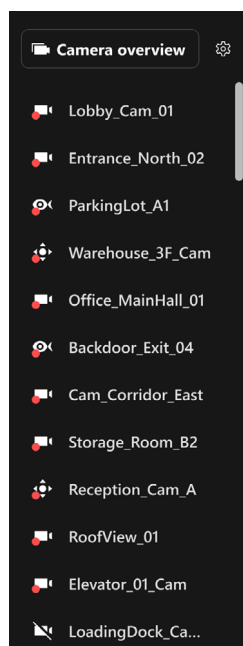

All connected cameras are listed in the left panel under “Camera overview” in the order configured in the system. Their live video streams appear in the central viewing area according to the selected layout.

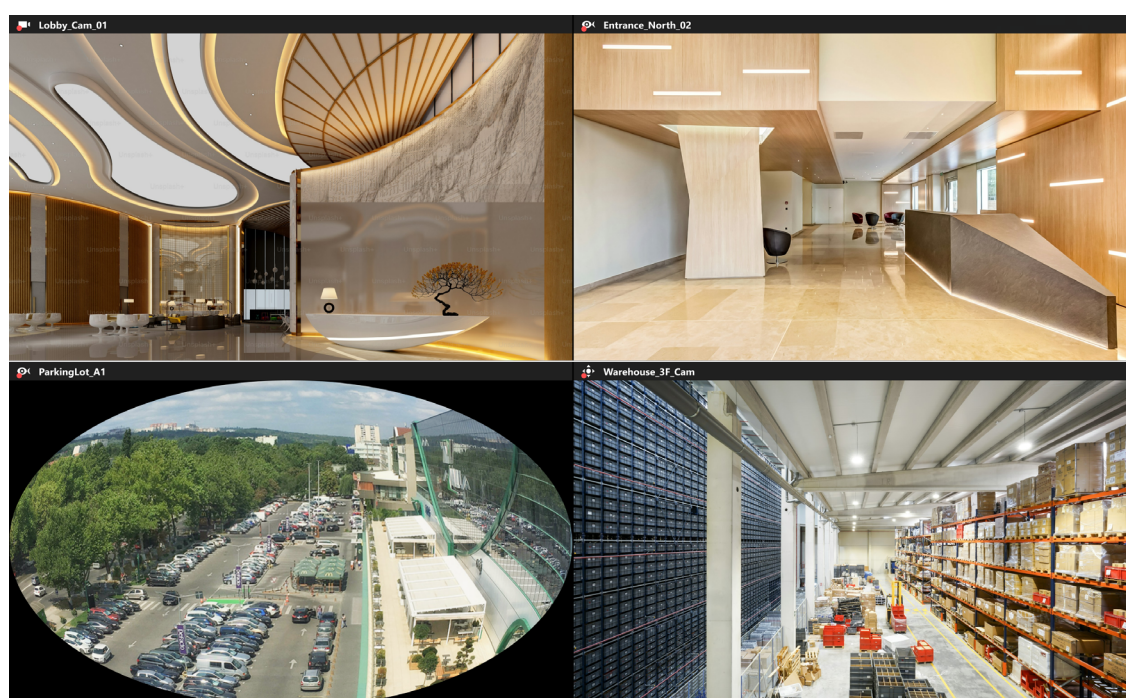

When the number of cameras exceeds the display capacity, the system automatically divides them into pages, which can be navigated using the pagination controls.

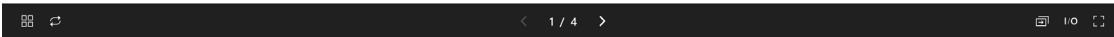

Web Interface

The web interface provides two viewing modes: **Device** and **Scene**, which can be switched using the tabs at the top of the left panel.

- **Device mode**

Displays all connected cameras in the order they were added to the NVR. The left panel lists the cameras, and the central viewing area shows their live streams based on the selected layout. This mode is suitable for monitoring all devices according to their connection order.

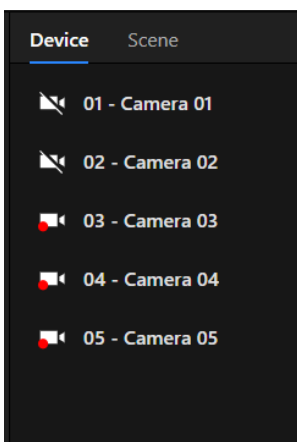

- **Scene mode**

Allows creating and managing custom layouts with selected cameras from one or multiple devices. This mode is useful for organizing views based on monitoring needs rather than physical connection order.

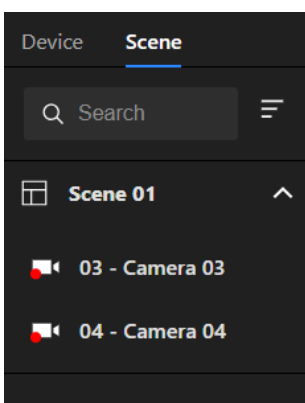

Create a New Scene

1. When entering Scene mode for the first time, the central viewing area displays an empty state message: "Your scene is empty. Let's add some new scene!" This indicates that no scenes have been configured.

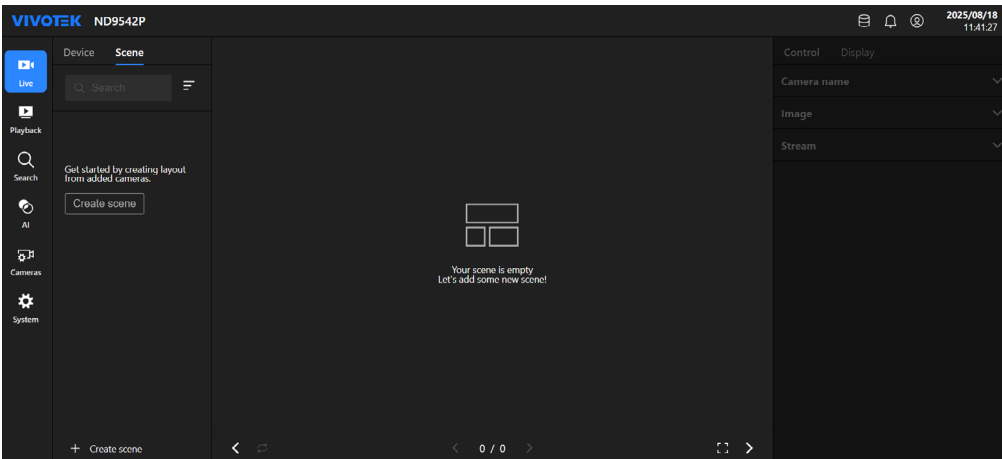

2. Click the **Create scene** button under the empty state message “Get started by creating layout from added cameras.” To open the scene configuration page.

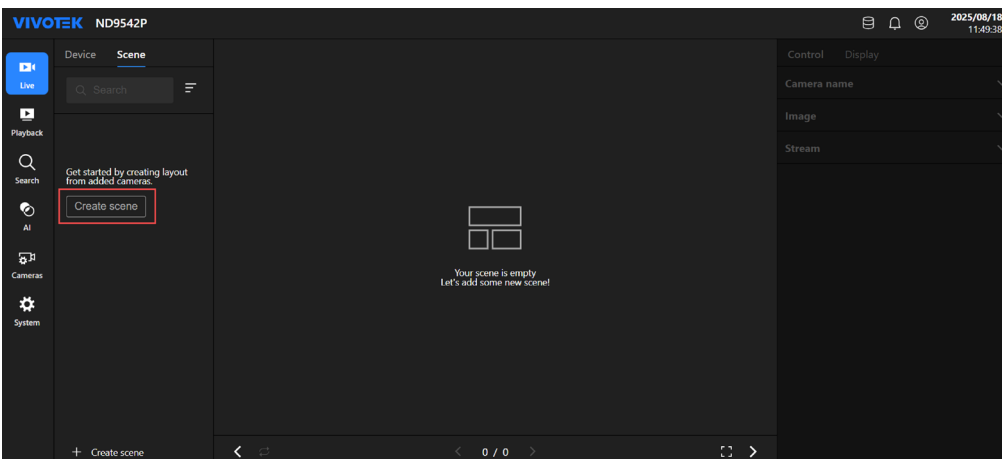

3. In the **Create New Scene** window, enter a name for the new scene in the **Scene name** field.

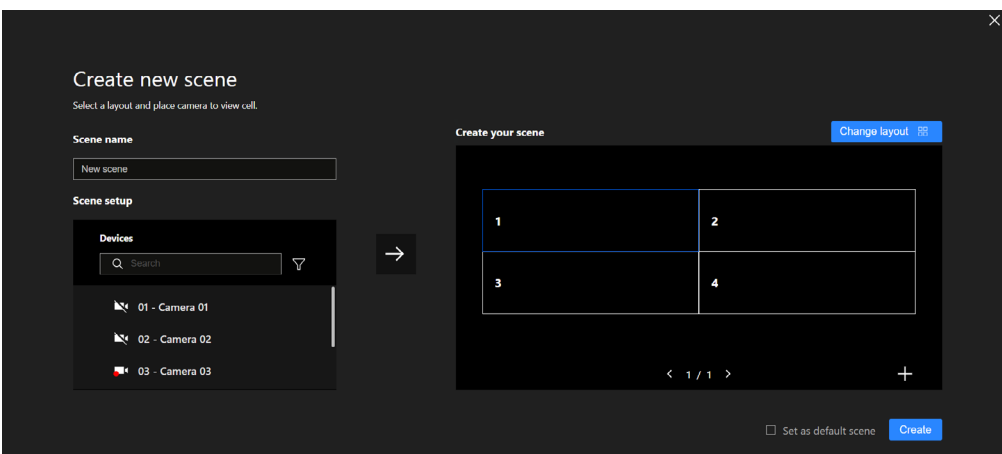

4. Select a layout by clicking **Change layout**, then choose the preferred grid arrangement.

5. Assign cameras to each cell by using either method:

- **Drag-and-drop:** Drag a camera from the **Devices** list to the desired cell in the live display area.
- **Select-and-assign:** Click a grid cell to highlight it with a blue border, select a camera from the **Devices** list, and click the arrow icon to place the camera into the selected cell.

- (Optional) Select **Set as default scene** to automatically load this scene when entering Scene.
- Click **Create** to finalize the configuration and add the new scene to the Scene list.

Edit an Existing Scene

- In Scene mode, select the scene to be modified from the Scene list in the left panel. Click the more options icon  next to the scene name and select **Edit** from the menu.

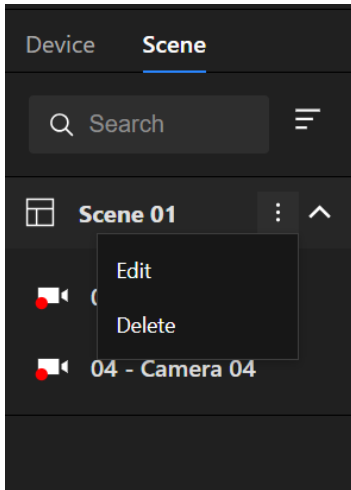

- The **Edit scene** window opens. Update the scene configuration as needed.

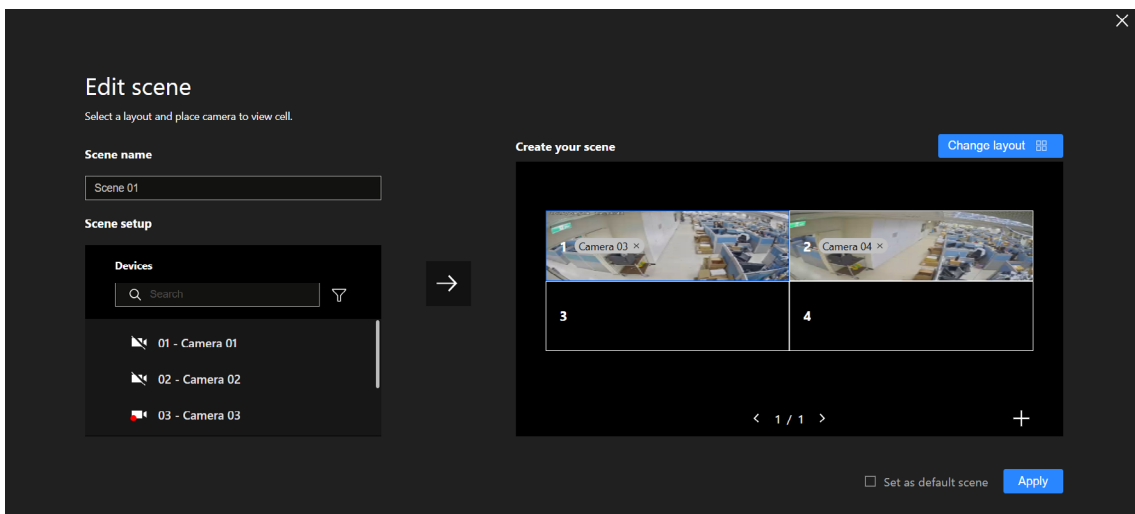

- Change the scene name in the **Scene name** field.
 - Select a different layout using the **Change layout** button.
 - Reassign cameras to grid cells by dragging and dropping them into the desired cells, or by selecting a cell and clicking the arrow icon to place the camera into it.
- (Optional) Check **Set as default scene** to automatically load this scene when entering Scene mode.
 - Click **Apply** to save the updated configuration.

Layout Management

The layout management tools allow customizing the arrangement of camera feeds in the central viewing area for optimal monitoring. Available options vary between the Local Console and Web Interface.

Local Console

The bottom toolbar provides the following controls:

- **Change layout** – Opens a menu of predefined grid layouts, such as 1×1, 2×2, 3×3, and mixed patterns.
- **Rotate** – Rotates all camera feeds in the current layout.
- **Pagination** – Switches between pages when the number of connected cameras exceeds the display capacity.
- **Go to sub-screen** – Sends the current view to a secondary connected display.
- **DIDO** – Opens the Digital Input/Output control panel for triggering or monitoring connected devices.
- **Full screen** – Expands the central viewing area to fill the display, hiding all other interface elements.

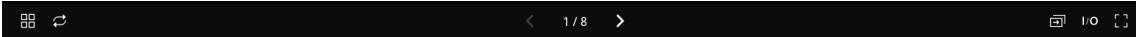

Web Interface

The bottom toolbar includes:

- **Change layout** – Switches between available grid layouts to adjust the number of camera feeds displayed at once.
- **Rotate** – Rotates all camera feeds in the current layout.
- **Pagination** – Switches between pages when the number of connected cameras exceeds the display capacity.
- **Full screen** – Expands the central viewing area to fill the display, hiding all other interface elements.

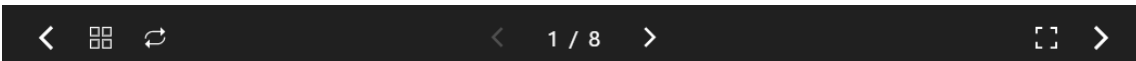

Controlling Individual Camera Feeds

Individual camera feeds can be highlighted and controlled without affecting the display of other channels. Available controls vary between the Local Console and Web Interface.

Local Console

In the local console, selecting a camera feed in the central viewing area highlights it with a blue border. This activates the **camera control bar**, which appears at the bottom of the selected feed.

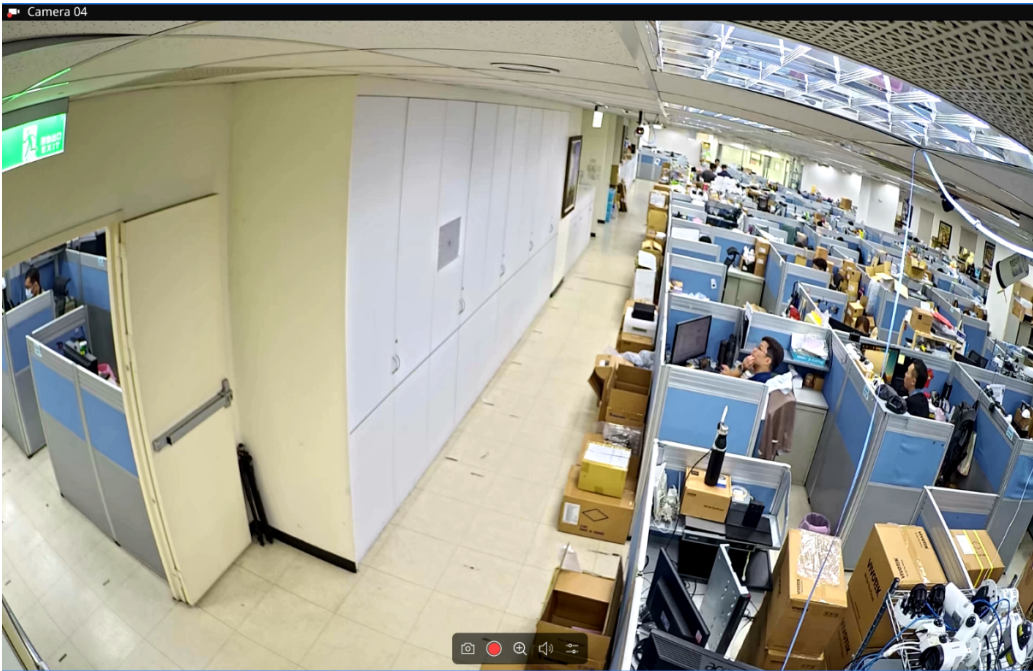

The camera control bar provides the following functions:

- **Snapshot** – Captures a still image from the selected feed.
- **Manual recording** – Starts or stops manual recording of the selected camera.
- **Digital zoom** – Enables zooming in on the selected feed.
- **Audio volume** – Adjusts the playback volume for the selected feed.
- **More settings** – Access additional camera-specific options.

The control bar automatically hides after 5 seconds of inactivity and reappears when the mouse is moved over the selected feed. Detailed descriptions of More settings options are provided in the next section.

More Settings

Clicking **More settings** opens a menu with advanced options for the selected camera feed.

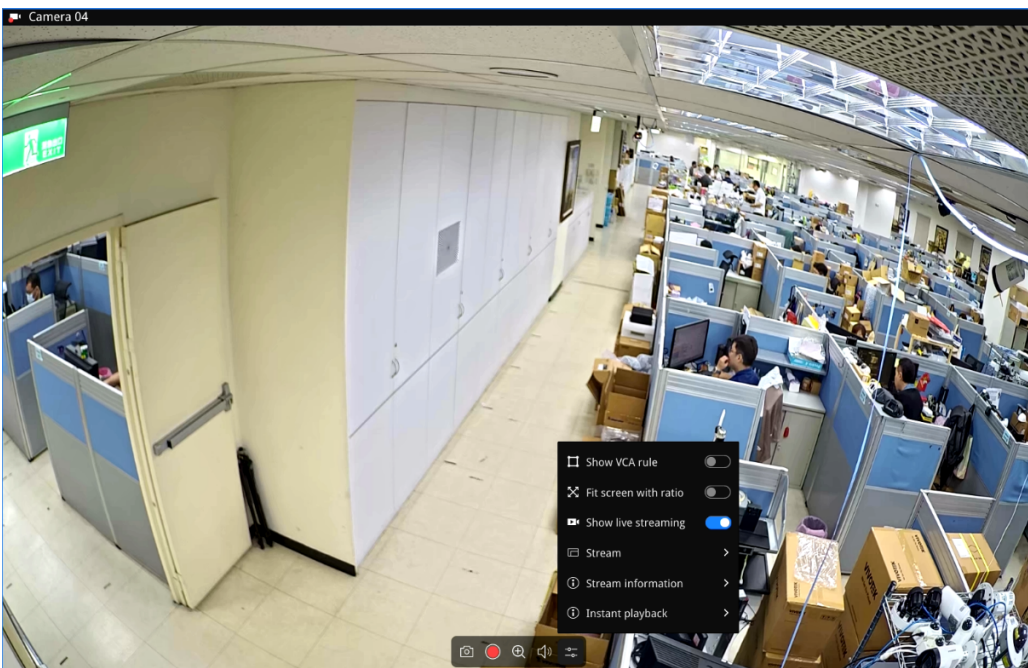

- **Show VCA rule** – Display configured VCA rules and metadata overlay on the video feed.
- **Fit screen with ratio** – Maintain the original aspect ratio of the video within the view cell. When enabled, the video feed maintains its original aspect ratio; when disabled, the feed stretches to fill the cell, which may alter the aspect ratio.
- **Show live streaming** – Toggle live streaming display on or off.
- **Stream** – Select the stream profile: Auto, Main stream, or Sub stream. In Auto mode, the system chooses the profile based on view cell size to optimize quality and performance, displaying an “Invalid resolution” message if the selected stream cannot be rendered.
- **Dewarp mode** – Apply dewarping for fisheye or panoramic cameras, with layout options such as 1O (original view), 1P (panorama), 1R (rectilinear), and combinations like 1O+3R for simultaneous overall and regional views.
System resource limitations restrict all fisheye dewarp modes (1O, 1R, 1O+3R, 1O+8R) to a single 1x1 view cell, allowing only one fisheye camera at a time.
- **Stream information** – View details such as resolution, codec, and frame rate.
- **Instant playback** – Play recorded footage from predefined time intervals (e.g., 1 min, 3 mins, 10 mins, 1 hour, 1 day ago).

Web Interface

In the web interface, clicking a camera cell displays overlay controls on the selected feed. These controls provide quick access to essential functions without leaving Live View. Available controls can include:

- **Snapshot** – Captures a still image from the selected feed.
- **Display Toggle** – Shows or hides VCA or Trend Micro overlays on the video feed.
- **Maximize View** – Expands the selected feed to fill the Live View area.

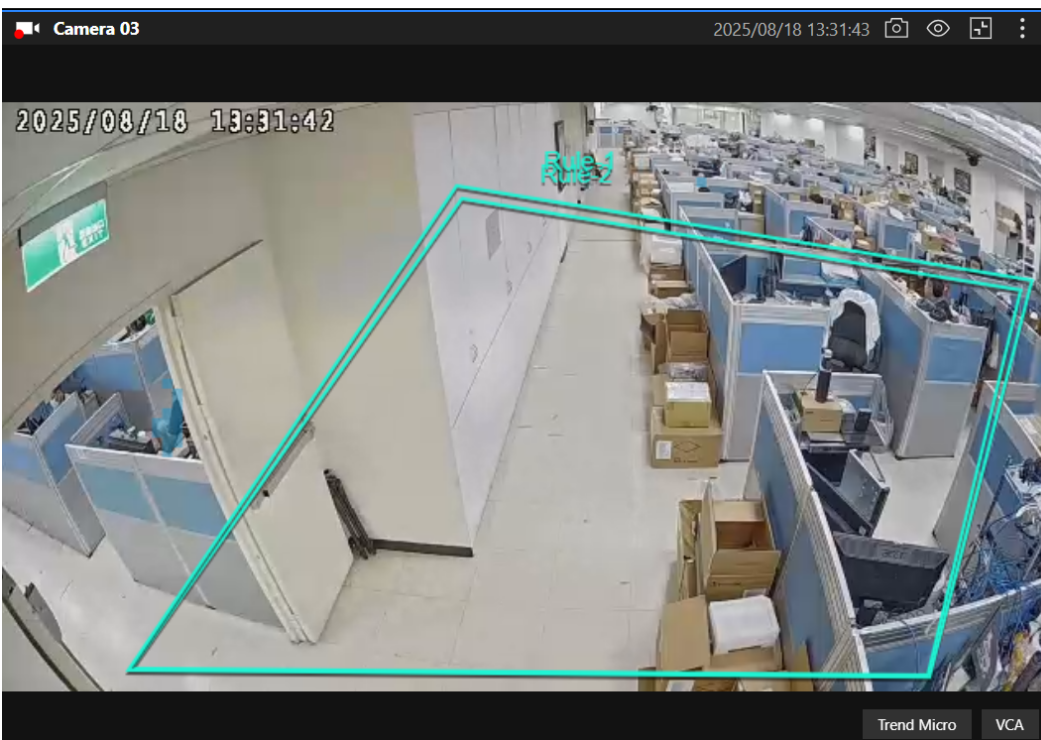

Using the Control Panel

When a feed is selected, the **Control Panel** appears on the right side of the interface, providing camera-specific controls. The panel contains the following sections:

Control Tab

- **Camera Information** – Displays details such as IP address, model, resolution, codec, and frame rate.
- **Manual Record** – Starts or stops manual recording for the selected camera.
- **Snapshot** – Captures a still image from the live feed and saves it to the designated storage location.
- **Bookmark** – Creates a bookmark for the current live video.
- **Image** – Includes the “Fit screen with ratio” option to maintain the original aspect ratio, or stretches the image to fill the cell.
- **Audio** – Adjusts playback volume for the selected feed. When muted, audio will not be recorded.
- **Stream** – Switches between the main stream and sub stream profiles.
- **Digital Zoom** – Enables or disables digital zoom for the selected feed.
- **Fisheye** – (Fisheye or panoramic cameras only) Selects the dewarp display mode (1O, 1P, or 1R).
- **DIDO** – Configures digital input and digital output status for the selected camera. Multiple channels (e.g., DI-1, DI-2, DO-1, DO-2) can be individually set to On or Off.

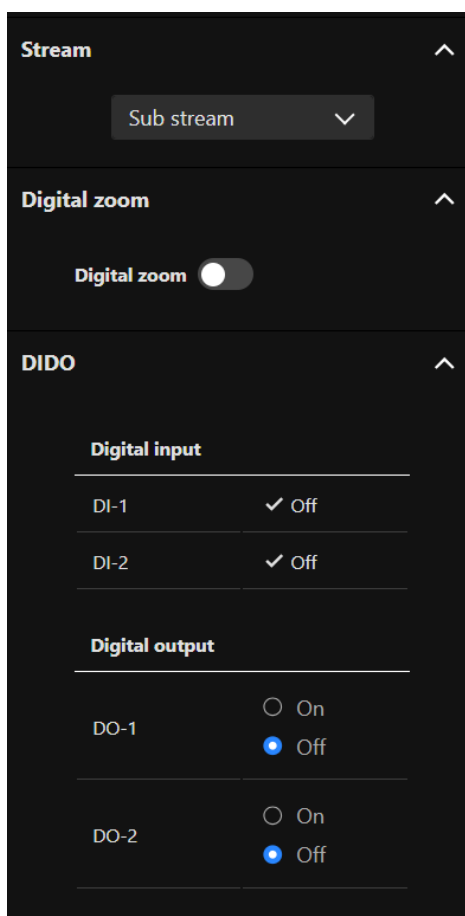
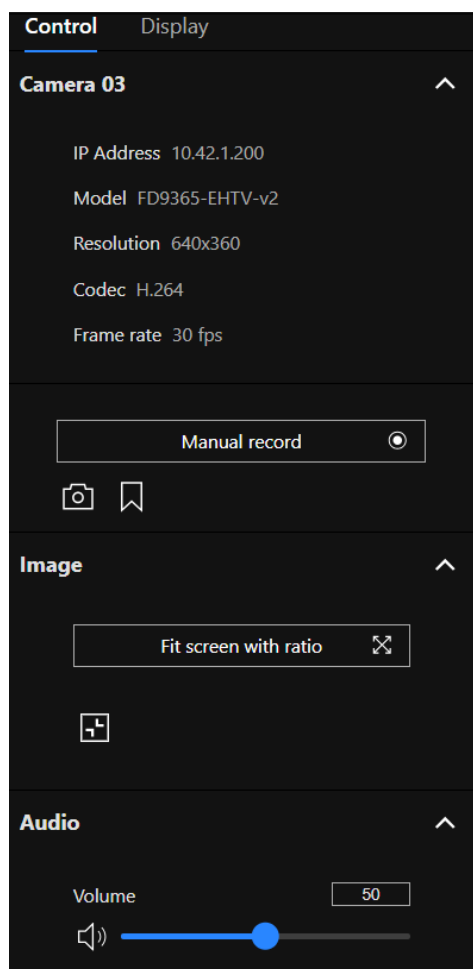

Display Tab

- **Status Bar** – Shows or hides camera information overlays, including type, name, IP address, and time. Options can be applied to all view cells.
- **Camera Status** – Toggles the display of Trend Micro IoT Security and Video Content Analysis status indicators. Options can be applied to all view cells.

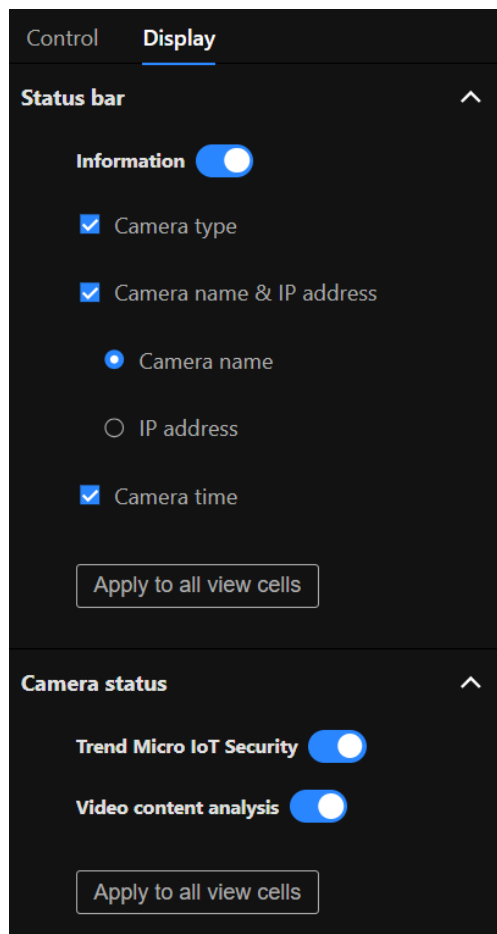

Playback

The Playback module allows reviewing recorded video from connected cameras, enabling investigation of past events or verification of specific time periods. The interface provides tools for selecting cameras, defining a time range, controlling playback speed, and marking important segments for reference or export.



Accessing Playback

To open the **Playback** page, select **Playback** from the navigation panel.

The page displays the following main sections:

- **Camera List** – Located on the left panel, showing all connected cameras with checkboxes for selecting one or multiple channels.
- **Calendar and Timeline** – Positioned below the camera list, used to select the recording date and time range for review.
- **Video Display Area** – Shows the playback streams of the selected cameras, with each feed displayed in its assigned cell.
- **Control Toolbar** – Located beneath the video area, providing playback controls, event tags, and export options.



Camera and Time Selection

In **Playback**, select the desired cameras and specify the recording period to review footage.

Selecting Cameras

From the **Camera List** in the left panel, select one or more cameras to display their recorded footage.

- In single-cell layout (1×1), selecting another camera replaces the current view.
- In multi-cell layouts (e.g., 2×2), selecting additional cameras fills available cells in order. Deselecting a camera removes its feed from the display.

When switching to a different camera, the system loads the corresponding recorded footage for the currently selected date and time. If no footage is available, the message “No recording clips” appears in the view cell.

Selecting a Date and Time

Use the calendar beneath the camera list to choose the desired recording date.

- Dates with available recordings are selectable.
- Clicking a date without available recordings displays the message “No recording clips.”

Use the timeline to navigate to the desired playback time.

- Click or drag along the timeline to set the playback position.
- Zoom in or out for more precise time selection.

Changing the date or time updates the playback content for all selected cameras simultaneously.

Playback Controls and Event Tags

The playback controls and event tags allow precise review of recorded footage, adjustment of viewing layouts, and quick access to specific incidents.

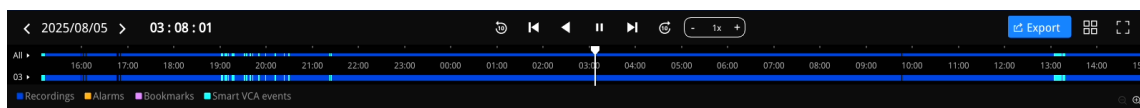

Playback Controls

The playback toolbar, located below the display area, contains functions for controlling video playback:

- **Play / Pause** – Starts or pauses playback at the current position.
- **Reverse Playback (Local Only)** – Plays footage in reverse for reviewing earlier activity without manually moving the timeline. If playback speed is changed during reverse playback, speed resets to the smallest reverse step.

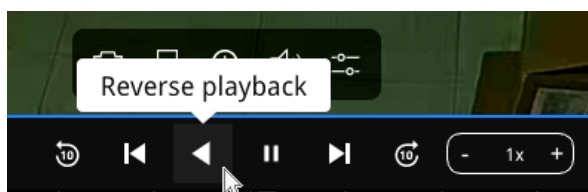

- **Playback Speed** – Adjusts playback speed (e.g., 0.5x, 1x, 2x). Speed changes apply to both forward and reverse playback.
- **Previous Frame (Local only)** – Moves playback one frame backward for detailed examination.

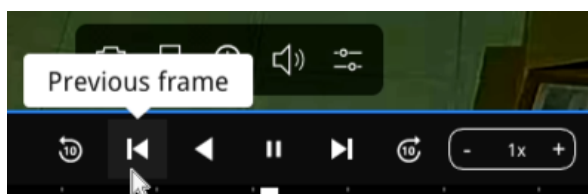

- **Next Frame** – Moves playback one frame forward for detailed examination.
- **Rewind / Forward 10 Seconds** – Jumps playback 10 seconds backward or forward from the current position.
- **Sync Playback / Time Align (Web only)** – Aligns all displayed cameras to the same playback time as the selected focus camera, ensuring synchronized review across multiple channels.

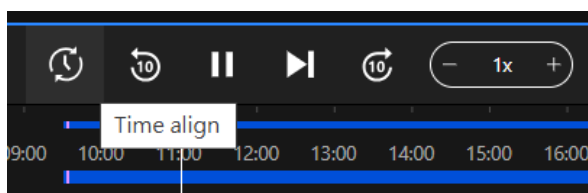

- **Change Layout** – Switches between single-view and multi-view layouts.
- **Single View / View All** – Expands a single camera feed to full view or returns to the selected multi-camera layout.

Playback Control Hotkeys

The following table lists the hotkeys for playback control buttons.

NOTE

Hotkeys are not supported on macOS systems.

Tooltip	Windows
Play / Pause	Space (Local only)
Reverse playback	Shift + Space (Local only)
Speed up	Shift + = Shift + Scroll Up
Slow down	Shift + - Shift + Scroll Down
Previous Frame	Ctrl + < (Local only)
Next Frame	Ctrl + >
Rewind 10 seconds	<
Forward 10 Seconds	>
Time Align	Ctrl + Shift + S
Full screen	F
Exit full screen	F
Export	E
Zoom in	Ctrl + = Ctrl + Scroll Up
Zoom out	Ctrl + - Ctrl + Scroll Down

Camera Control Bar

When a camera cell is selected, a control bar appears over the feed, providing quick access to camera-specific actions:



- **Snapshot** – Captures a still image from the current frame without interrupting playback.
- **Bookmark** – Saves the current playback position for future reference; bookmarks appear on the timeline as event tags.
- **Digital Zoom** – Magnifies a selected area of the video feed for closer inspection.
- **Audio** – Adjusts the playback volume for the selected channel.
- **More Settings** – Opens a menu with additional options.

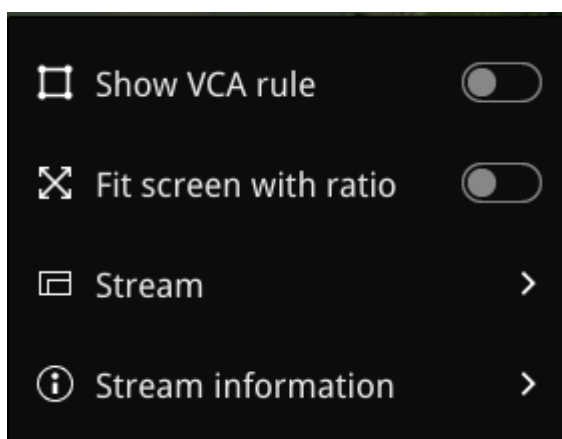

- **Show VCA rule** – Displays or hides configured VCA overlays.
- **Fit screen with ratio** – Adjusts video scaling while maintaining the original aspect ratio.
- **Stream** – Selects the streaming profile (e.g., resolution, bitrate).
- **Stream information** – Displays detailed stream data such as resolution, codec, and frame rate.

- **Show live streaming** – Switches from playback mode to the live stream of the selected camera.
- **Dewarp mode** – Available only for fisheye cameras; switches between dewarped and original fisheye view.
 - **Local:** Always available.
 - **Web:** Availability depends on the Dewarp mode setting in the camera profile.

Event Tags and Timeline

The timeline shows color-coded **event tags** marking important points in the recording. These tags make it easy to locate and review key moments without scanning through the entire footage.

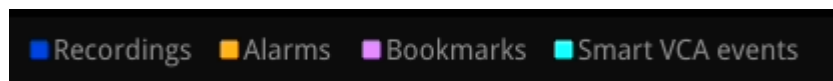

- **Blue** – Continuous recordings
- **Orange** – Alarm-triggered recordings
- **Purple** – Bookmarked segments
- **Green** – Smart VCA events

Bookmarks can be added during playback and are stored with the recording for later access. Event tags remain visible when zooming or panning the timeline, allowing quick navigation within any time range.

Exporting Recorded Footage

The Export function allows saving recorded video clips for backup, sharing, or evidence purposes. The export process differs between the Local Console and Web interface.

Click the **Export** button at the bottom-right corner of the Playback page to begin.

On the **Local Console**, the process consists of three steps: **Configuration**, **Disk Space Evaluation**, and **Export**; on the **Web interface**, the process is streamlined to **Configuration** and **Export** only.

Local Console

On the local console, the export process involves a three-step workflow:

1. Configuration

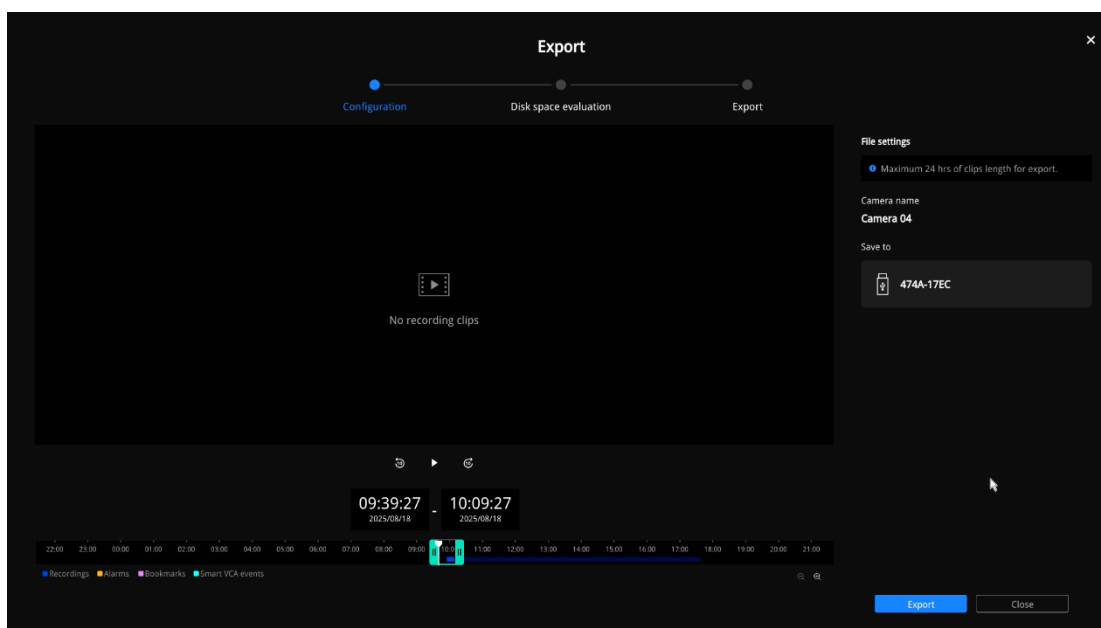

- Select the desired date and time range using the timeline and date picker.
- Configure **File Settings**, including:
 - **Camera Name** – Displays the selected camera’s name.
 - **Save To** – USB storage device.
 - **File Format** – Selectable from available formats (e.g., .zip, .mp4).

2. Disk Space Evaluation

After configuration, the system evaluates the available storage capacity of the connected USB device. A progress indicator with the message “**Calculating disk capacity...**” is displayed during this step.

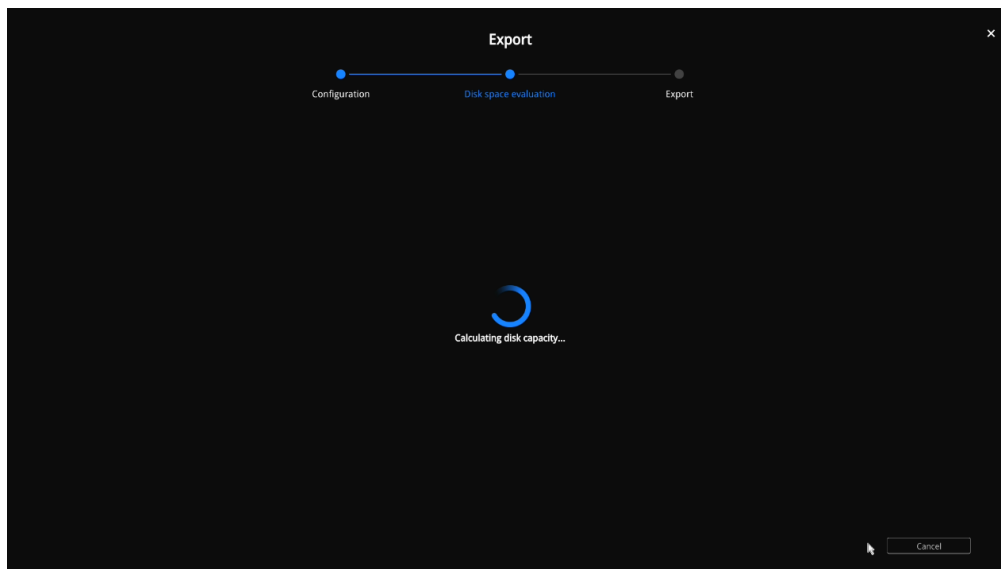

- If the available space is sufficient, the process proceeds to the export stage.
- If the space is insufficient, a warning page appears showing both the **required** and **available** capacity, along with options to retry the calculation (**Try Again**) or return to the Video Export configuration page (**Cancel**).

3. Export

- The **Exporting** screen shows a progress indicator with estimated remaining time.

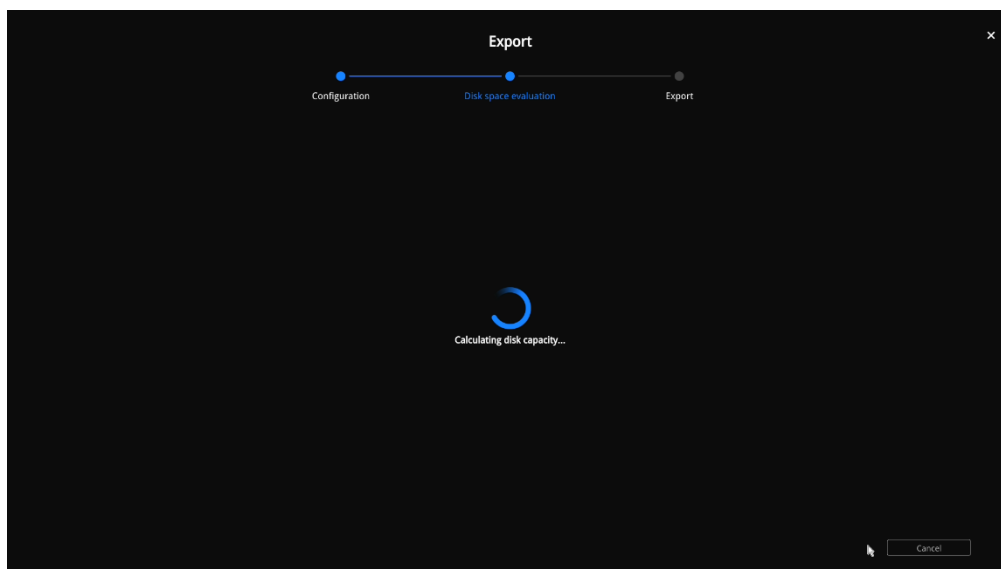

- Once completed, the **Export Successfully** screen appears.

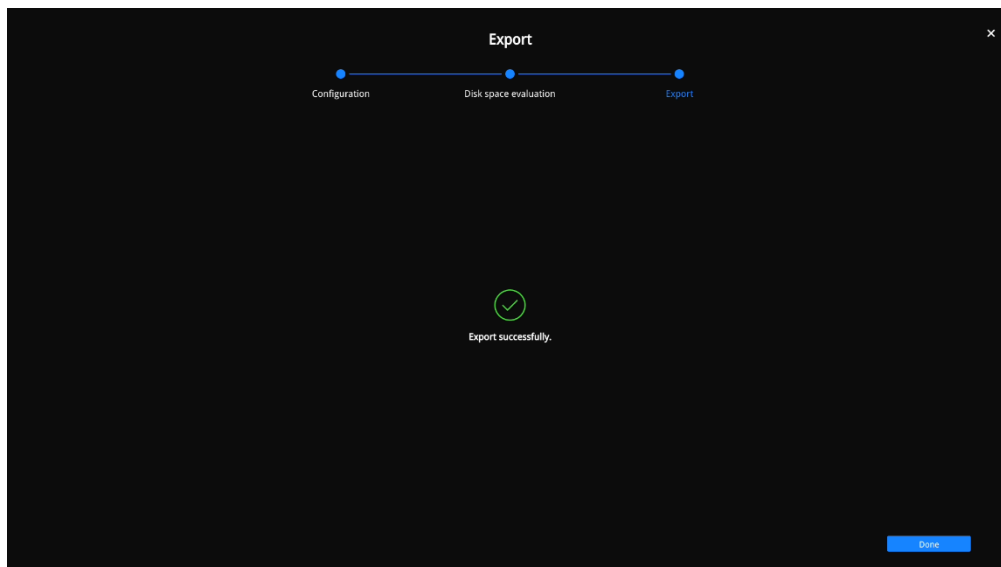

- Click **Done** to return to the Video Export page.

Web Interface

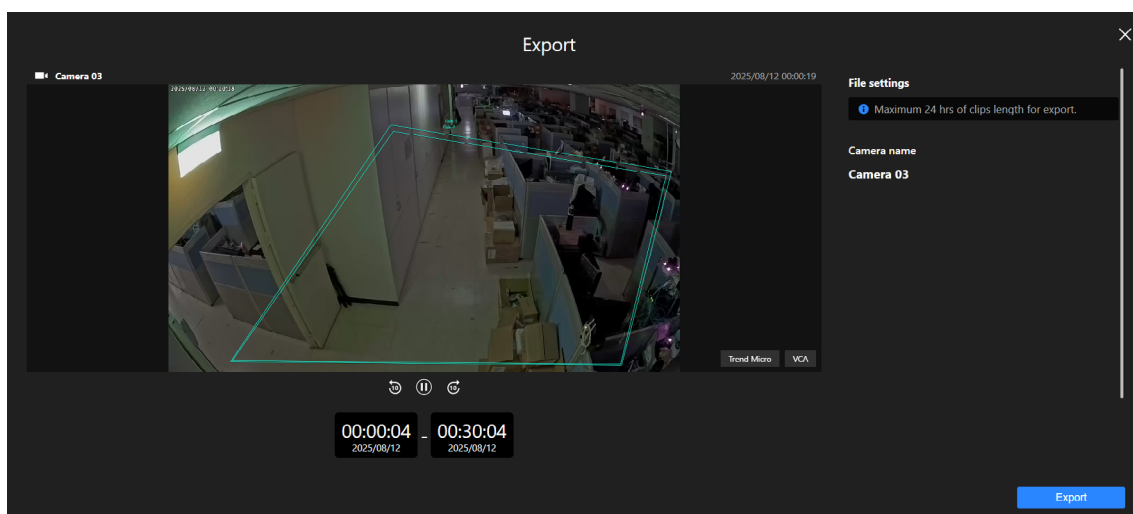

On the Web interface, the export process is streamlined:

1. In the **Playback** page, select the desired camera from the camera list and choose the date and the approximate time range on the timeline.
2. Click **Export** to open the **Export** page, adjust the exact date, start time, and end times for the export.
3. The **File Settings** panel on the right-hand side displays the camera name to be exported.
4. Click **Export** again to start processing; the button will display **Exporting**.
5. The browser's file save dialog appears, allowing the user to choose the storage location.
6. The file is downloaded directly to the specified folder.

NOTE

- **Time Range Restrictions** – The export time range must be at least 1 minute and no longer than 24 hours.
- **Platform Differences** –
 - **Save To USB** and **Disk Space Evaluation** steps are **Local Console only**.
 - Web exports rely on the browser's download functionality and do not require USB storage.

Search

The **Search** module provides tools to locate and review recorded events or video clips based on specific criteria.

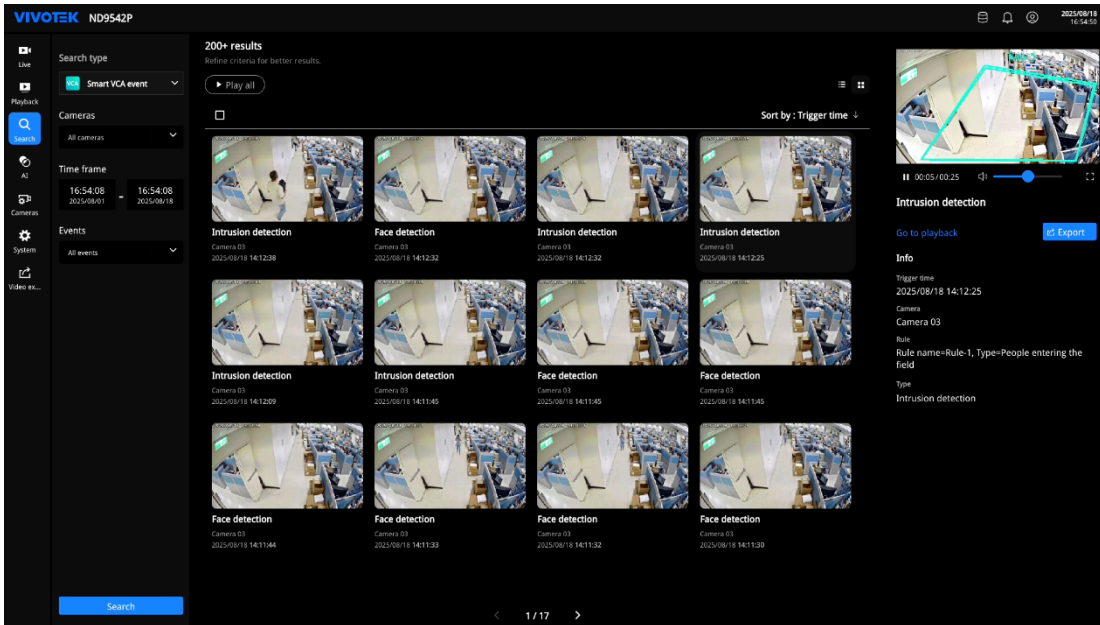

It supports multiple search types, including:

- **Alarm** – Lists alarm-triggered recordings with related details.
- **Smart VCA Event** – Displays results generated by VCA rules for advanced analytics.
- **Trend Micro IoT Security** – Shows cybersecurity events detected by the Trend Micro IoT Security service.
- **Bookmark** – Retrieves user-defined bookmarked recordings.

Each search type provides dedicated filters and result fields, enabling precise searches based on the selected category.

Alarm Search

The **Alarm Search** feature provides a way to locate and review recordings generated by alarm events. The interface provides filter options to narrow search results, a results table for browsing events, and a preview panel for viewing and exporting selected recordings.

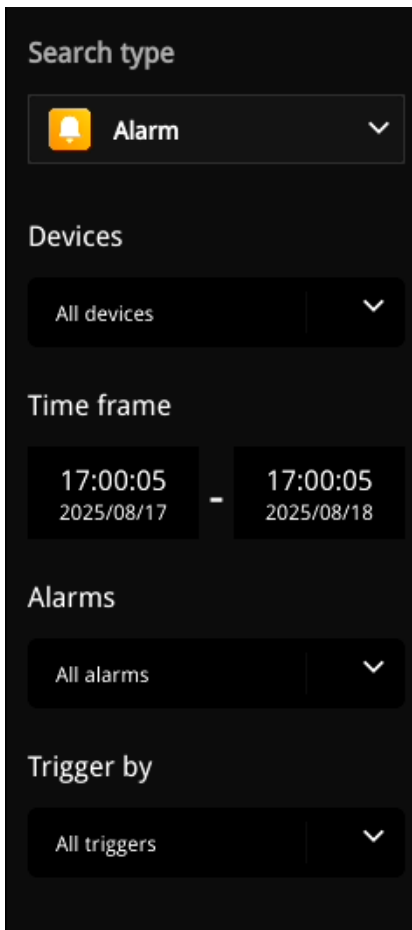

Setting Search Criteria

To begin an alarm search, use the filters in the left panel to define the search scope:

- **Devices** – Select a specific camera or NVR or choose All devices.

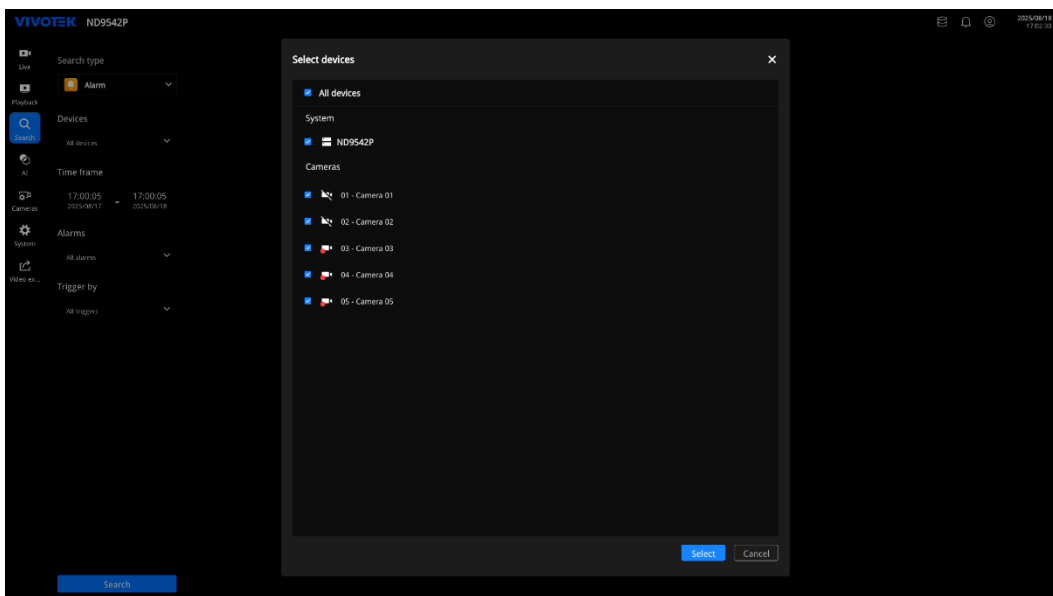

- **Time frame** – Specify a start and end date/time using the time picker to limit the search period.
- **Alarms** – Filter by a specific alarm type or select All alarms.

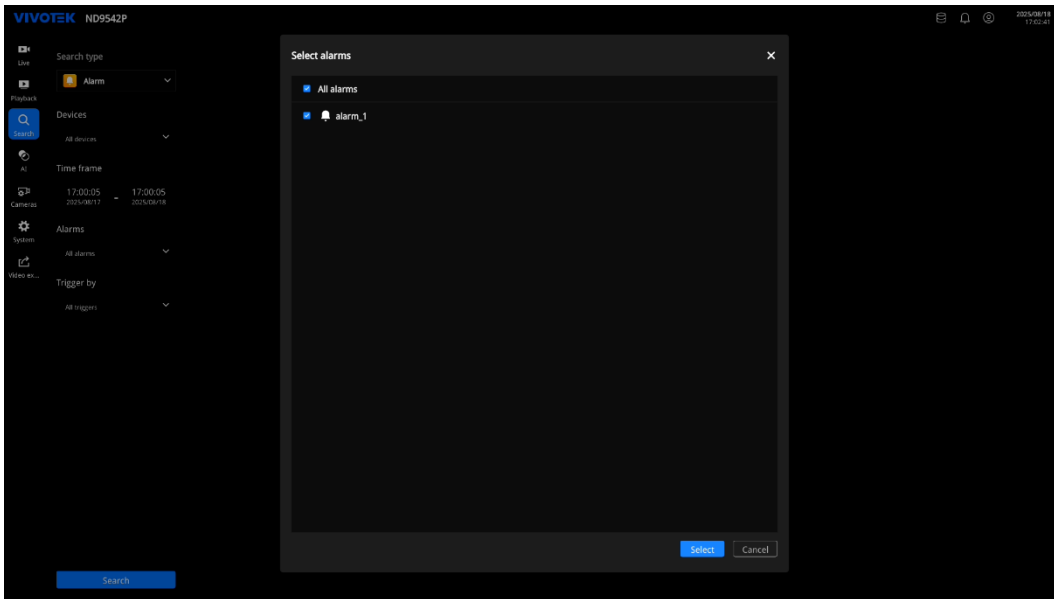

- **Trigger by** – Choose the trigger source from available categories, such as General, Smart VCA, Thermal, or Trend Micro IoT Security, or select All triggers to include every option.

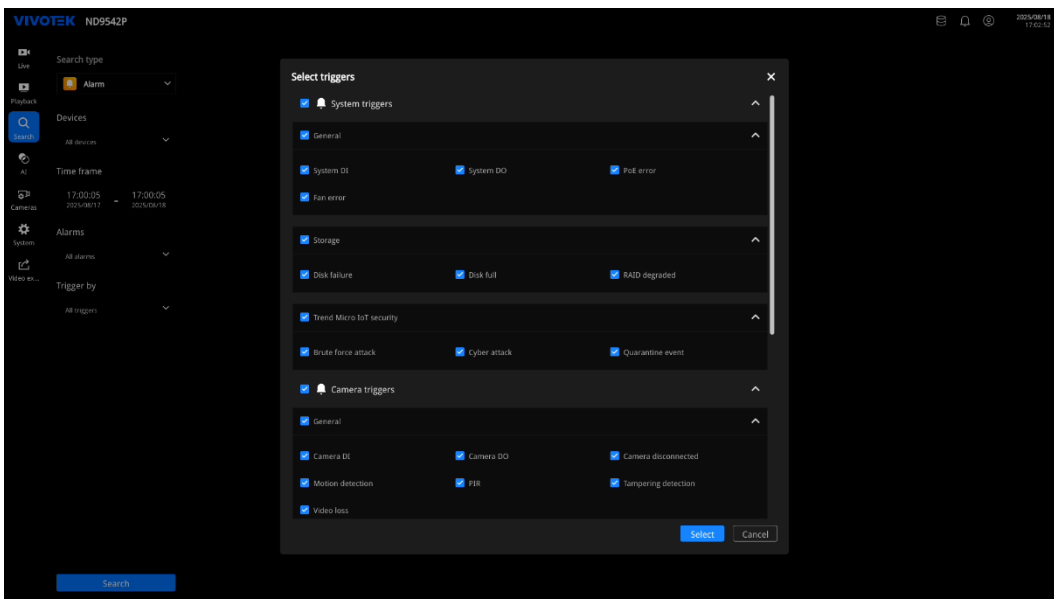

After setting the criteria, click **Search** at the bottom of the panel to display results matching the selected parameters.

Viewing Search Results

Matching events appear in the results table, with each row showing:

- **Alarm name** – Name of the triggered alarm.
- **Start time** – Date and time the alarm was triggered.
- **Device** – Name of the device that recorded the alarm.
- **Trigger by** – The configured trigger condition or source.

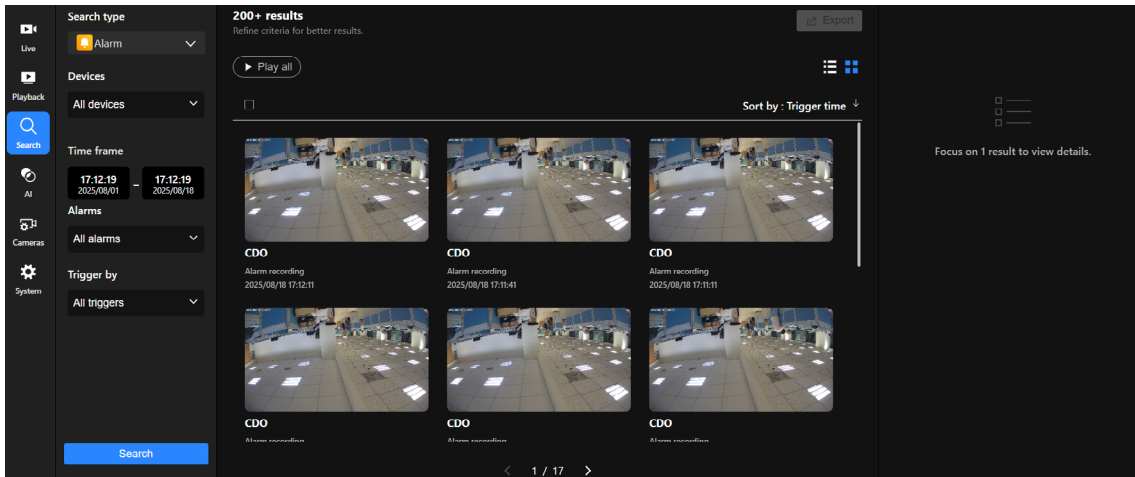

When no result is selected, the right panel remains empty. Selecting a result or clicking the **Play** icon displays the preview panel. Playback can be initiated in several ways:

- Click **Play all** to play all results sequentially in the preview window.
- Click the **Play** button next to an individual result to start playback for that clip.
- Select multiple results and click **Play all** to play them in order.

When playback begins, the right panel displays a preview window along with detailed information, including the start time, device name, trigger type, and—if multiple clips are available—a playlist for navigation. The panel also provides action buttons such as **Go to playback** and **Export**.

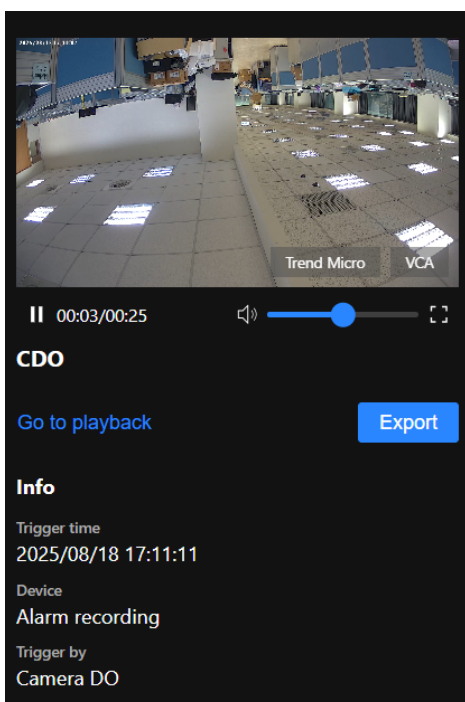

The preview window supports full-screen mode, where the control bar includes options to toggle **Show VCA rule** and **Fit screen with ratio** on the Local Console, and additionally **Stream** and **Stream information** on the Web interface.



Local Interface



Web Interface

Exporting Alarm Search Results

To export recordings:

1. Select the desired events from the results table.
2. Click Export to open the export configuration screen.

The export process consists of three stages (local console):

- **Configuration** – Review selected events, choose the file format (mp4 or zip), and specify the save location. (On Local Console, exports can be saved to a connected USB device.)
- **Disk space evaluation** – The system checks available space on the selected storage destination.
- **Export** – Progress and estimated remaining time are displayed.

For web interface, after clicking **Export**, the browser's file save dialog appears, allowing the user to choose the storage location.

When export completes successfully, the file is saved to the specified location.

NOTE

- **Time Range Restrictions** – The export time range must be at least 1 minute and no longer than 24 hours.

Smart VCA Event Search

The **Smart VCA Event Search** function allows searching for recorded video clips triggered by configured VCA rules. This helps quickly locate footage based on specific detection types and time periods.

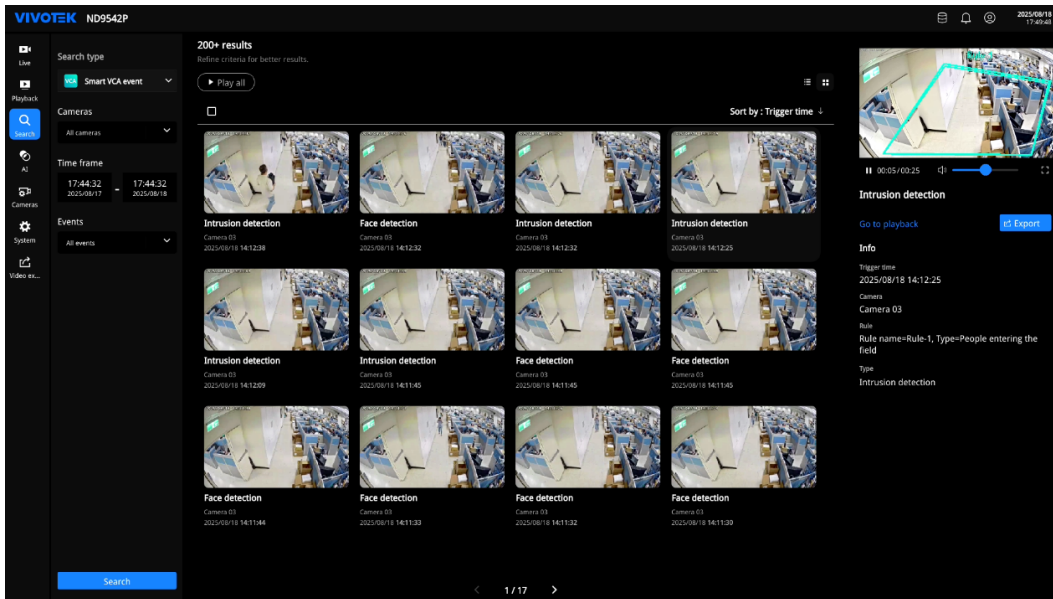

Setting Search Criteria

To begin a Smart VCA event search, use the filters in the left panel to define the search scope:

- **Cameras** – Select a specific camera or choose All cameras.

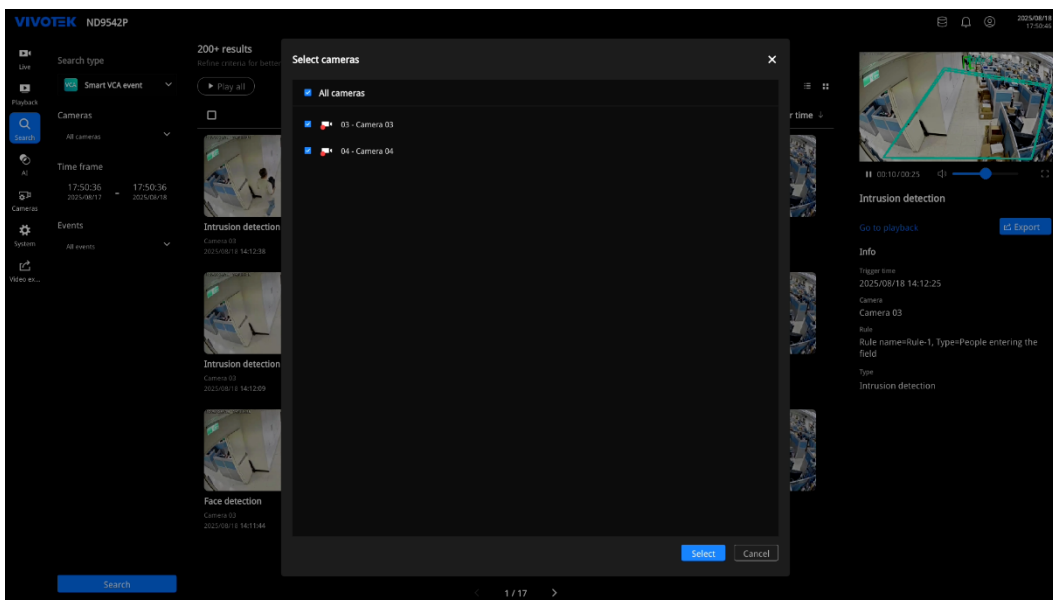

- **Time frame** – Specify a start and end date/time using the time picker to limit the search period.
- **Events** – Filter by a specific VCA event type or select All events to include every option. Event types include crowd detection, face detection, intrusion detection, line crossing detection, loitering detection, missing object detection, parking violation detection, restricted zone detection, running detection, smart tracking advanced, and unattended object detection.

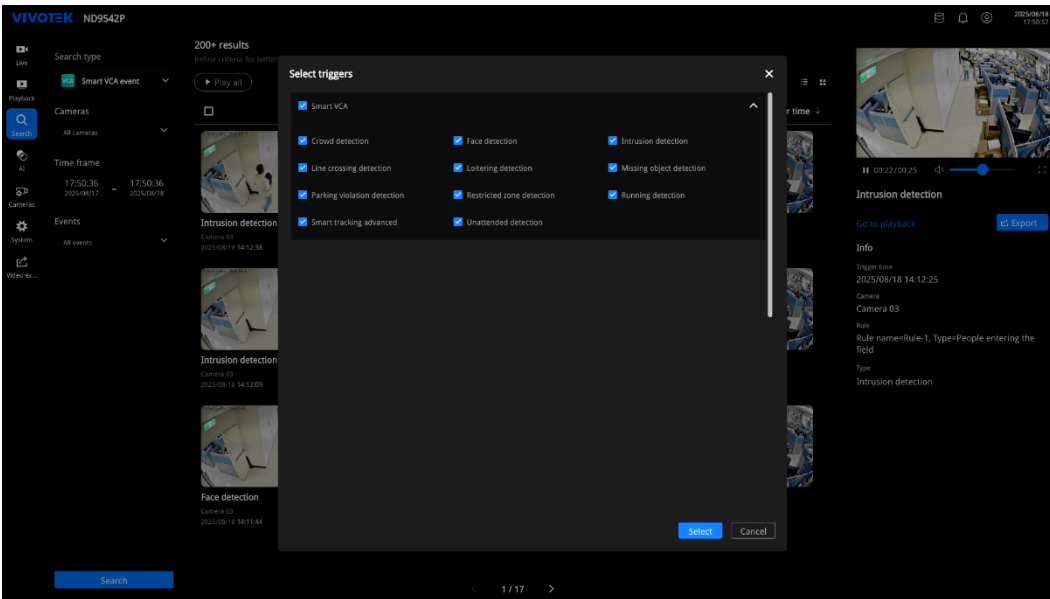

After setting the criteria, click **Search** at the bottom of the panel to display results matching the selected parameters.

Viewing Search Results

Matching events appear in the results table, with each row showing:

- **Event name** – Name of the detected VCA event.
- **Start time** – Date and time the event occurred.
- **Camera** – Name of the camera that recorded the event.
- **Rule name** – The configured rule that triggered the event.

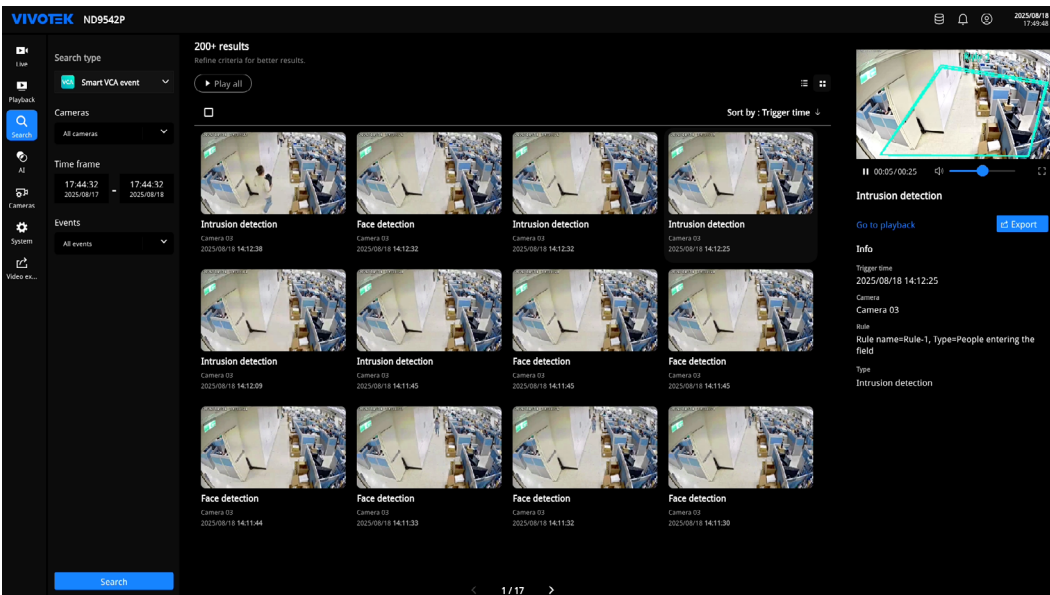

When no result is selected, the right panel remains empty. Selecting a result or clicking the **Play** icon displays the preview panel. Playback can be initiated in several ways:

- Click **Play all** to play all search results sequentially in the preview window.

- Click the **Play** button next to a specific event to start playback for that clip.
- Select multiple events and click **Play all** to play only the selected clips in order.

When playback begins, the right panel displays a preview window along with detailed information, including the start time, camera name, rule name, and—if multiple clips are available—a playlist for navigation. The panel also provides action buttons such as **Go to playback** and **Export**.

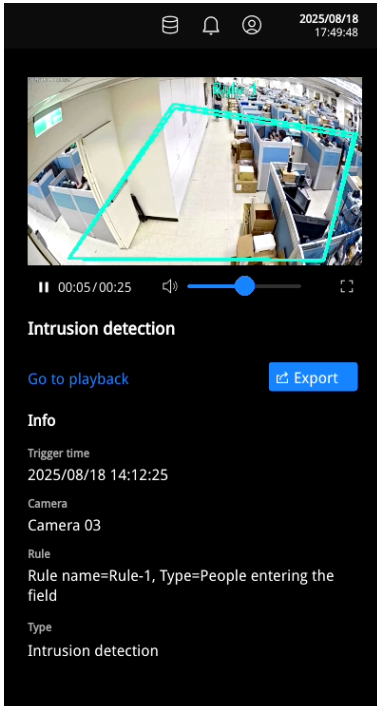

The preview window supports full-screen mode, where the control bar includes options to toggle **Show VCA rule** and **Fit screen with ratio** on the Local Console, and additionally **Stream** and **Stream information** on the Web interface.

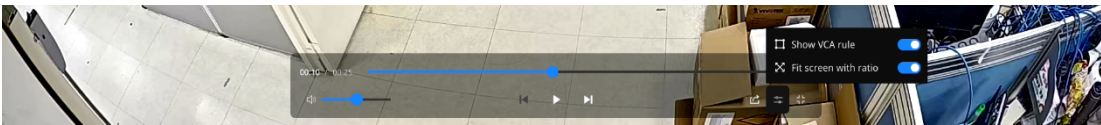

Local Interface



Web Interface

Exporting Smart VCA Event Search Results

To export recordings:

1. Select the desired events from the results table.
2. Click Export to open the export configuration screen.

The export process consists of three stages (local console):

- **Configuration** – Review the selected events, choose the file format (**.mp4** or **.zip**), and specify the save location. On Local Console, exports can also be saved to a connected USB device.
- **Disk space evaluation** – The system checks available space on the selected storage destination.
- **Export** – Progress and the estimated remaining time are displayed during processing.

For web interface, after clicking **Export**, the browser's file save dialog appears, allowing the user to choose the storage location.

When the export completes successfully, the file is saved to the specified location.

NOTE

- **Time Range Restrictions** – The export time range must be at least 1 minute and no longer than 24 hours.

Trend Micro IoT Security Search

The **Trend Micro IoT Security Search** function allows searching for recorded log entries related to Trend Micro IoT Security events detected by the system. This feature is useful for reviewing and exporting security-related activity in a structured format for further analysis.

Setting Search Criteria

To begin a Trend Micro IoT Security search, use the filters in the left panel to define the search scope:

- **Devices** – Select a specific device or choose **All devices**.
- **Time frame** – Specify a start and end date/time using the time picker to limit the search period.
- **Events** – Filter by a specific event type or select **All events** to include every option. Event types include **brute force attack**, **cyber attack**, and **quarantine event**.

After setting the criteria, click **Search** at the bottom of the panel to display results matching the selected parameters.

The screenshot shows the VIVOTEK ND9542P interface with search results for 'Cyber attack'. The left sidebar contains search filters: Search type (Trend Micro IoT Secu), Devices (All devices), Time frame (17:54:55 2025/08/17 to 17:54:55 2025/08/18), and Events (All events). The main panel shows 55 results, with a summary bar indicating 55 Cyber attack, 0 Brute force attack, and 0 Quarantine event. The table below lists the search results:

Device	Time	Event type	Message type	Peer IP address	Direction
Camera 03	2025/08/18 15:03:12	Cyber attack	Security rule	169.254.33.116:4132	Outside-in
Camera 03	2025/08/18 15:03:12	Cyber attack	Security rule	10.135.212.112:49870	Outside-in
Camera 03	2025/08/18 15:03:12	Cyber attack	Security rule	169.254.33.116:36462	Outside-in
Camera 03	2025/08/18 15:03:12	Cyber attack	Security rule	10.42.2.64:43703	Outside-in
Camera 03	2025/08/18 15:03:12	Cyber attack	Security rule	10.42.2.64:43640	Outside-in
Camera 03	2025/08/18 15:03:12	Cyber attack	Security rule	10.42.2.64:43608	Outside-in
Camera 03	2025/08/18 15:03:12	Cyber attack	Security rule	10.42.2.64:43557	Outside-in
Camera 03	2025/08/18 15:03:12	Cyber attack	Security rule	10.42.2.64:43518	Outside-in
Camera 03	2025/08/18 15:03:12	Cyber attack	Security rule	10.42.2.64:43480	Outside-in
Camera 03	2025/08/18 15:03:12	Cyber attack	Security rule	169.254.33.116:42365	Outside-in
Camera 03	2025/08/18 15:03:12	Cyber attack	Security rule	169.254.33.116:42365	Outside-in
Camera 03	2025/08/18 14:46:12	Cyber attack	Security rule	169.254.33.116:4132	Outside-in

Viewing Search Results

Matching security events appear in the results table. Above the table, three summary cards display the total count for each event type—**Cyber attack**, **Brute force attack**, and **Quarantine event**—based on the current search criteria.

Each row in the results table includes:

- **Device** – Name of the device where the event occurred.
- **Time** – Date and time of the event.
- **Event type** – Category of the detected security event.
- **Message type** – Classification of the event message.
- **Peer IP address** – IP address and port of the external endpoint involved in the event.
- **Direction** – Traffic direction (e.g., inside-out).
- **Details icon** – Opens a dialog with additional information about the selected event.

Selecting the details icon for an event displays its complete information in a separate dialog.

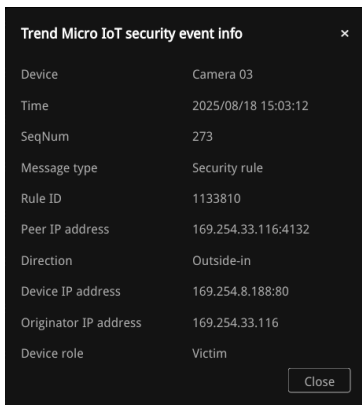

Exporting Trend Micro IoT Security Search Results

To export records:

1. Set the search criteria and click **Search** to display results.
2. Click **Export** in the upper-right corner of the results.

The system processes the request and displays a toast message.

- **Local Console** – When the export completes successfully, a confirmation message “Export successfully” appears, and a **.csv** file is saved to the connected USB storage device.
- **Web Interface** – When the export completes successfully, a **.csv** file is downloaded to the default browser download location.

Bookmark Search

The **Bookmark Search** function allows retrieving video clips that have been manually bookmarked during live monitoring or playback. This feature helps quickly access important footage without searching through the entire recording timeline.

Setting Search Criteria

To begin a bookmark search, use the filters in the left panel to define the search scope:

- **Cameras** – Select a specific camera or choose **All cameras**.
- **Time frame** – Specify a start and end date/time using the time picker to limit the search period.

After setting the criteria, click **Search** at the bottom of the panel to display results matching the selected parameters.

Viewing Search Results

Matching bookmarks appear in the results table, with each row showing:

- **Bookmark name** – Name assigned to the bookmark.
- **Start time** – Date and time the bookmarked recording begins.
- **Camera** – Name of the camera that recorded the bookmark.

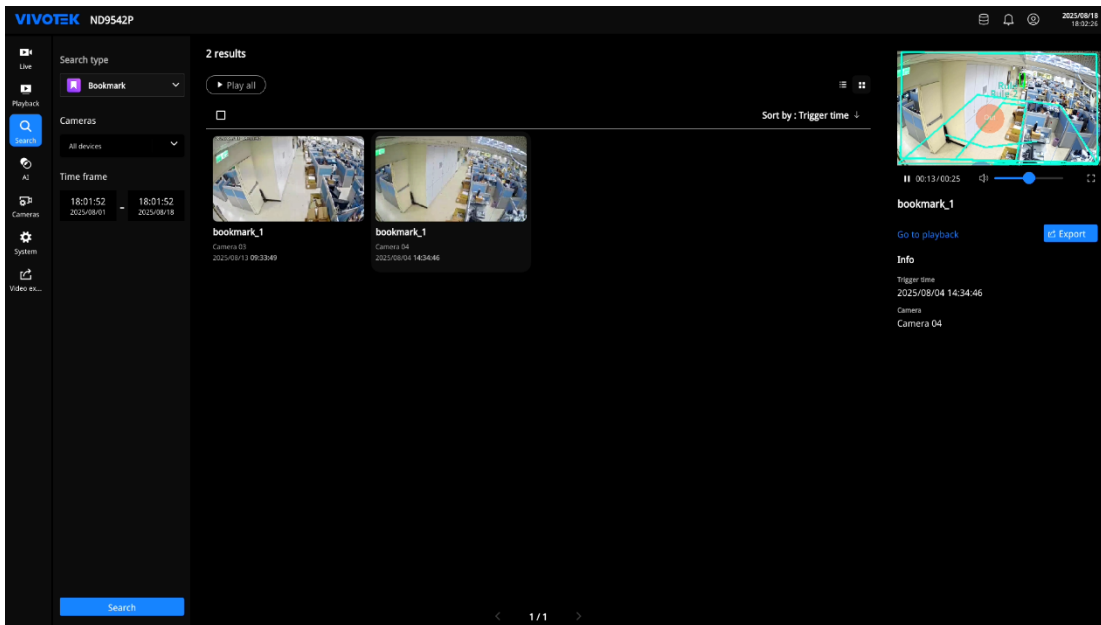

When no result is selected, the right panel remains empty. Selecting a result or clicking the **Play** icon displays the preview panel. Playback can be initiated in several ways:

- Click **Play all** to play all search results sequentially in the preview window.
- Click the **Play** button next to a specific bookmark to start playback for that clip.
- Select multiple bookmarks and click **Play all** to play only the selected clips in order.

When playback begins, the right panel displays a preview window along with detailed information, including start time, camera name, and—if multiple clips are available—a playlist for navigation. The panel also provides action buttons such as **Go to playback** and **Export**.

The preview window supports full-screen mode, where the control bar includes options to toggle **Show VCA rule** and **Fit screen with ratio** on the Local Console, and additionally **Stream** and **Stream information** on the Web interface.



Local Interface



Web Interface

Exporting Bookmark Search Results

To export recordings:

1. Select the desired bookmarks from the results table.
2. Click **Export** to open the export configuration screen.

The export process consists of three stages (local console):

- **Configuration** – Review the selected bookmarks, choose the file format (.mp4 or .zip), and specify the save location. On Local Console, exports can also be saved to a connected USB device.
- **Disk space evaluation** – The system checks available space on the selected storage destination.
- **Export** – Progress and the estimated remaining time are displayed during processing.

For web interface, after clicking **Export**, the browser's file save dialog appears, allowing the user to choose the storage location.

When export completes successfully, the file is saved to the specified location.

NOTE

- **Time Range Restrictions** – The export time range must be at least 1 minute and no longer than 24 hours.

The AI module provides advanced video analytics tools for quickly locating and reviewing specific activities captured in recorded footage. It supports both Smart Search II and Deep Search (local console only) functions, allowing searches to be conducted based on object characteristics, movements, and other analytic parameters.

Accessing AI

To open the AI module:

1. From the navigation panel, select **AI**.
2. The **AI** module displays available search tools, including Smart Search II and Deep Search (local only).

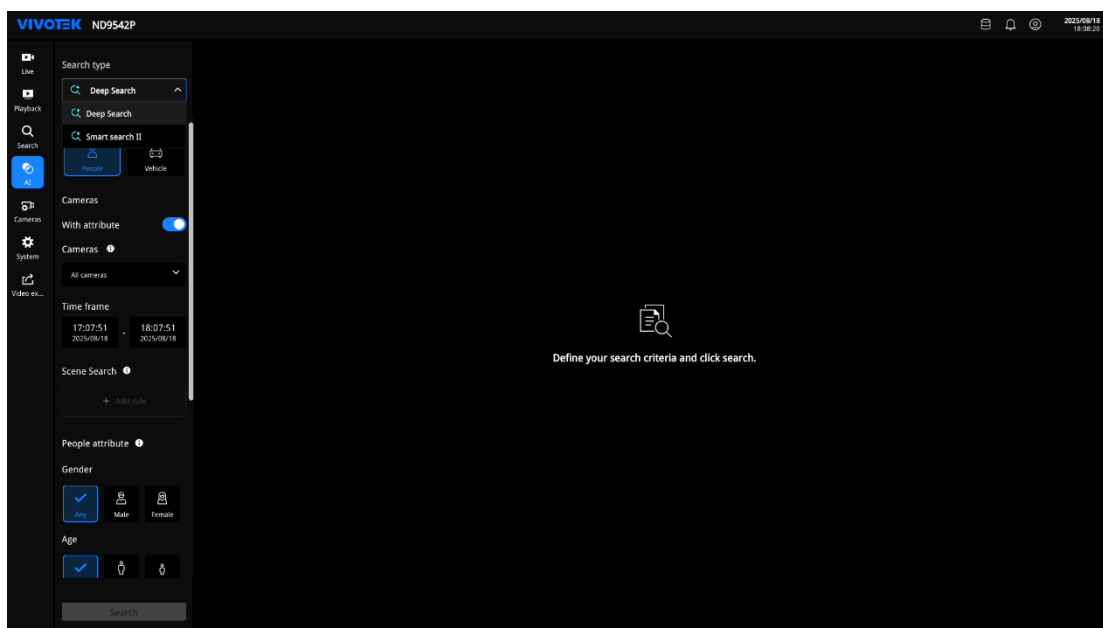

Using Smart Search II

Smart Search II is designed to quickly locate motion events within recorded video based on a defined area, time range, and detection parameters. The process is performed on one camera at a time, making it suitable for targeted incident reviews.

Cameras that support Deep Search use a different AI metadata format and are not compatible with Smart Search II; therefore, they will not appear in the camera selection list.

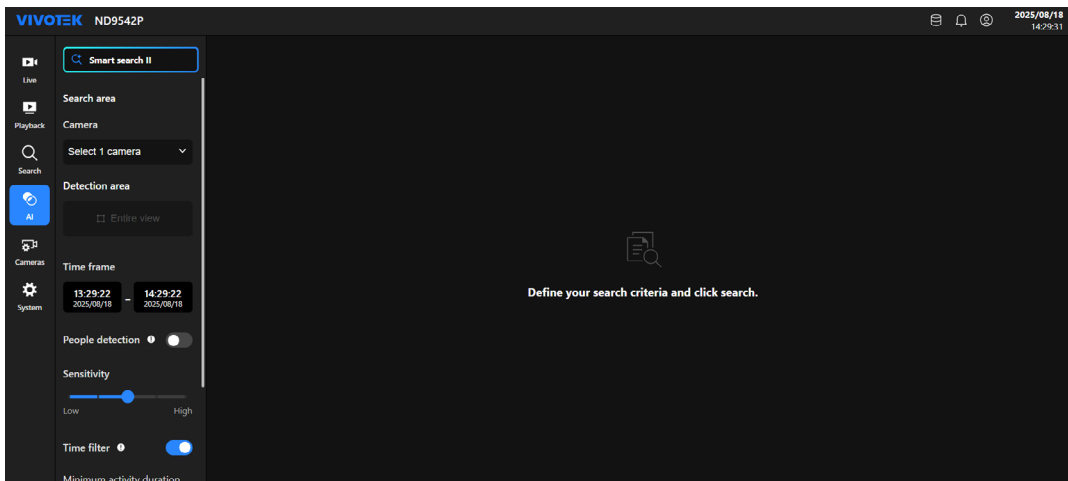

Setting Search Parameters

1. Select Smart Search II

Open the **AI** module and set **Search type** to **Smart Search II**.

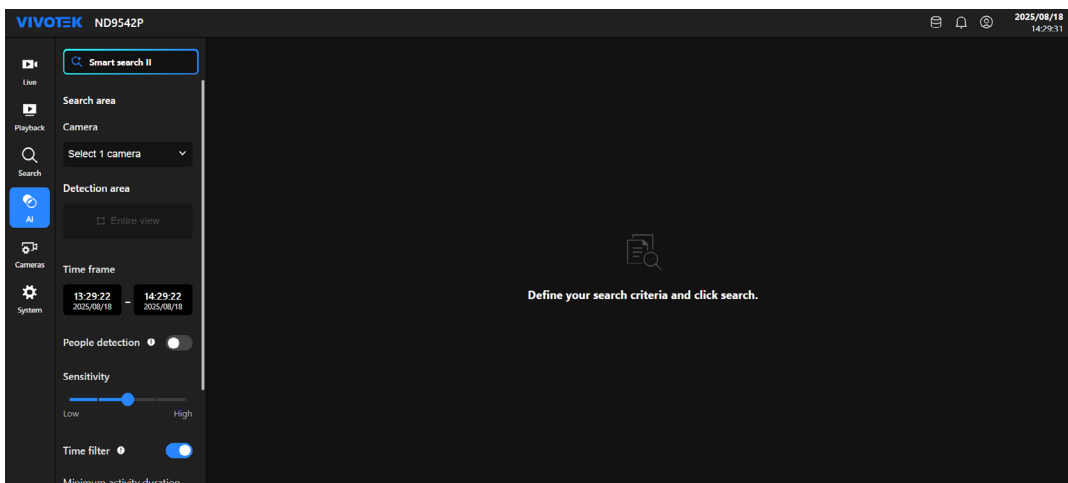

2. Choose a camera

Click **Camera** to open the selection window and choose one camera from the list, then click **Select**. Deep Search-enabled cameras are excluded to ensure compatibility.

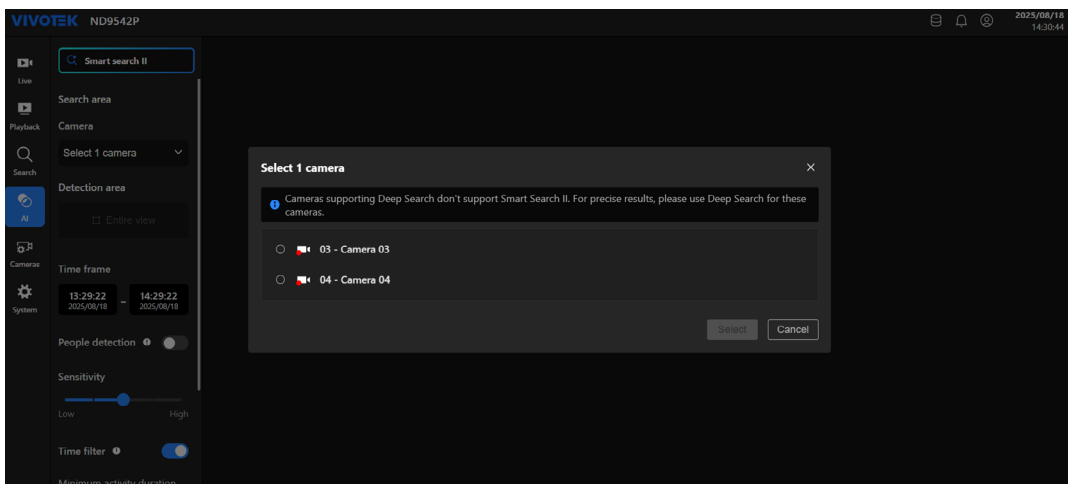

3. Define the search area (optional)

Click **Search area** to choose how the video will be analyzed:

- **Entire view** – Analyze the full image.
- **Custom area** – Draw a rectangular region on the preview. The region can be moved and resized using the on-screen handles. Click **Save** to apply.

Additional toggles may be available, such as **Exclusive area** or **People detection area**.

4. Set the time frame

Specify start and end date/time for the search range.

5. Enable People detection (if available)

Appears only when the selected camera supports metadata. When enabled, sensitivity controls are hidden. The tooltip explains the match condition: results are returned only when the center of the feet lies inside the detection area.

Adjust sensitivity (when People detection is off)

Choose from five levels: Very low, Low, Medium (default), High, Very high.

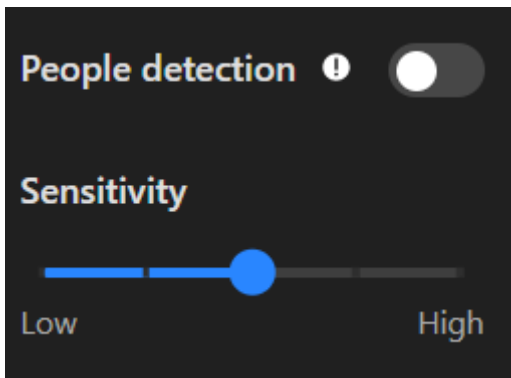

6. Apply time filter (optional)

Enable Time filter to refine detection by ignoring short events and merging nearby events:

- **Minimum activity duration** – Default: 500 ms
- **Activity merge interval** – Default: 1500 ms

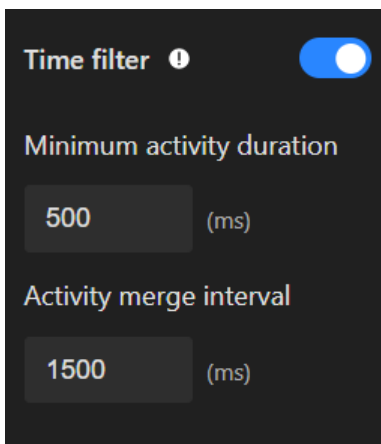

7. Start the search

Click **Search** to begin processing with the configured criteria.

Viewing and Managing Results

After the search completes, the results page shows the number of results on the top of the page, followed by a grid of thumbnails—each representing a detected motion event that meets the defined search parameters. Every card displays the event time, camera name, and date/time.

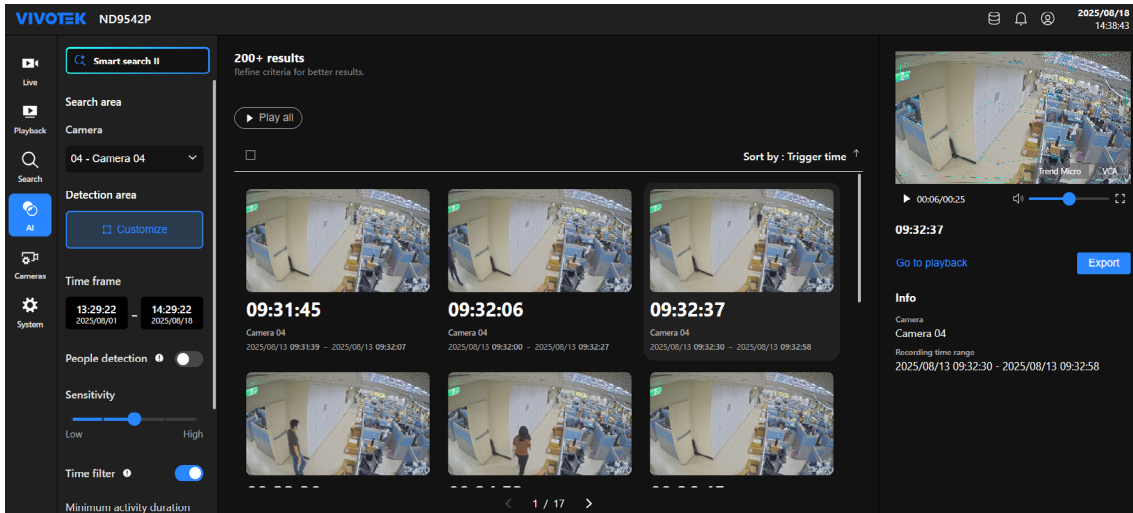

Selecting a thumbnail opens the **event preview panel** on the right. This panel provides playback controls, a progress bar, event details, and quick links to:

- **Go to playback** – Opens the full recording in the Playback module.
- **Export** – Downloads the selected event.

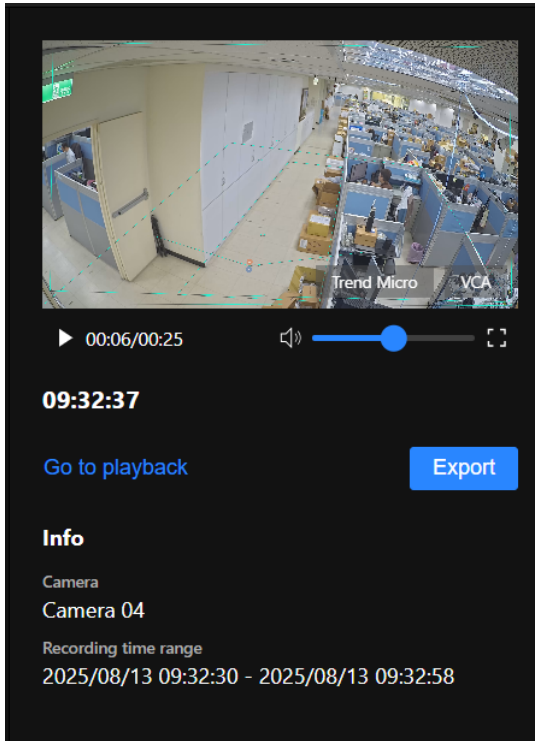

The **Play all** button plays all search results sequentially in the preview panel for continuous review. Results can be sorted by **trigger time**, in either ascending (A–Z) or descending (Z–A) order. For large result sets, refine the search criteria—such as narrowing the time frame or adjusting the detection area—to quickly locate relevant events.

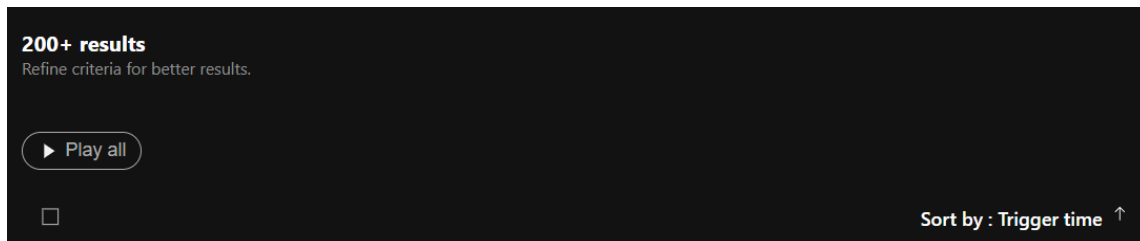

Using Deep Search

Deep Search (local only) leverages AI metadata to locate people or vehicles in recorded video based on object attributes, scene rules, and time range. Unlike Smart Search II, Deep Search supports searching across multiple cameras simultaneously. Only cameras with Deep Search capability and metadata collection enabled appear in the selection list.

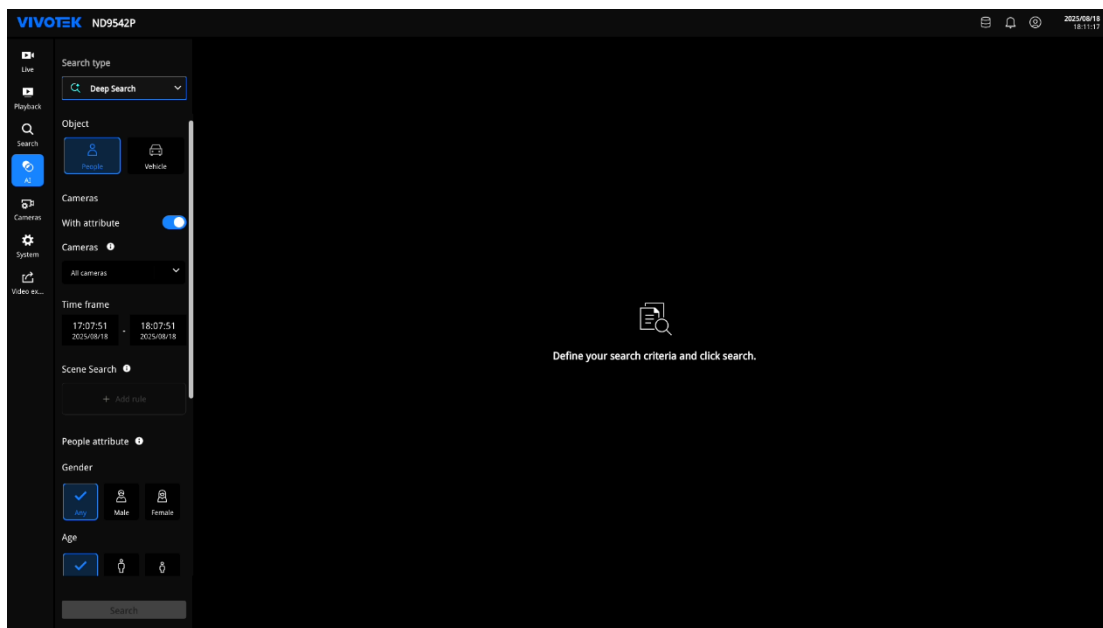

Setting Search Parameters

1. Select Deep Search

In the AI module, set **Search type** to **Deep Search**.

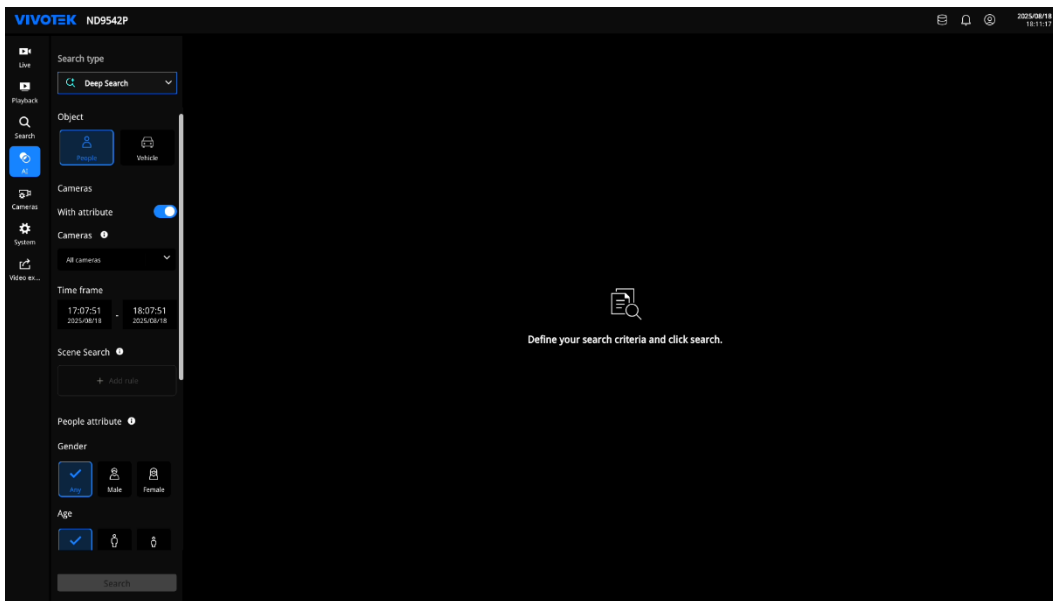

2. Choose the object category

Select **People** or **Vehicle**. The available filters and attributes depend on the selected category.

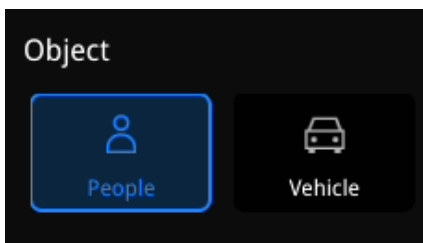

3. Select cameras

Click **Cameras** to open the selection dialog.

- Multiple cameras can be selected.
- The list only includes supported cameras with metadata collection enabled.
- Use the **All cameras** option to include all listed cameras.

Click **Select** to confirm.

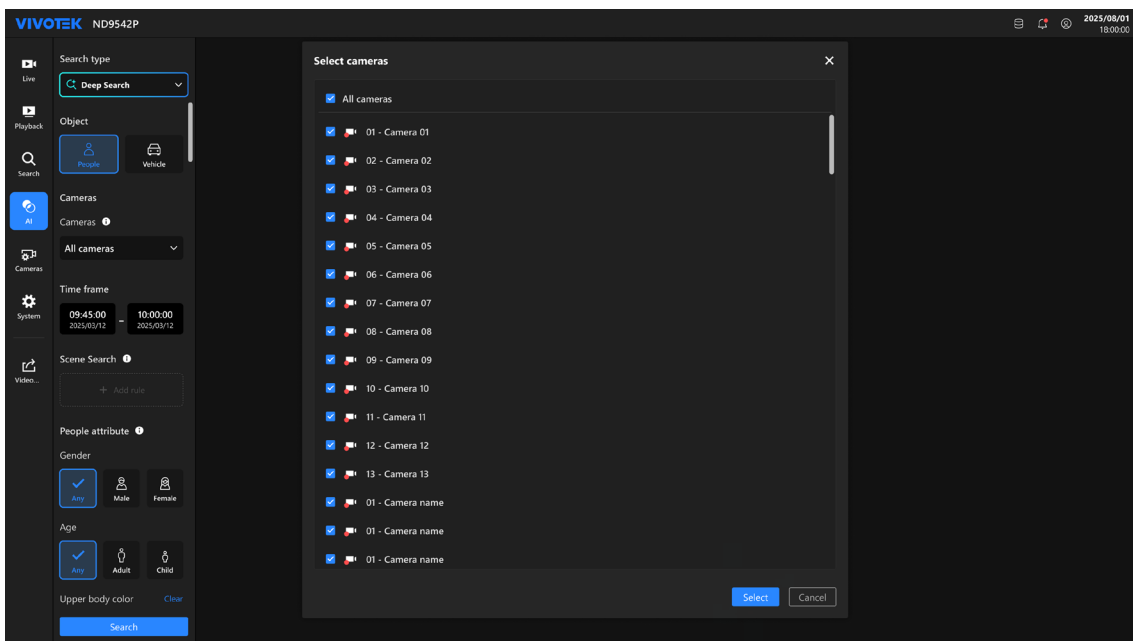

4. Set the time frame

Specify the start and end date/time for the search range.

5. Add a scene search rule (optional)

Click **Add rule** to define a detection rule:

- **Intrusion** – Detects objects entering or leaving a virtual area.
- **Line crossing** – Detects objects crossing a virtual tripwire.
- **Loitering** – Detects objects staying in an area longer than a preset threshold.

Use the on-screen tools to draw the area or line, then save the rule.

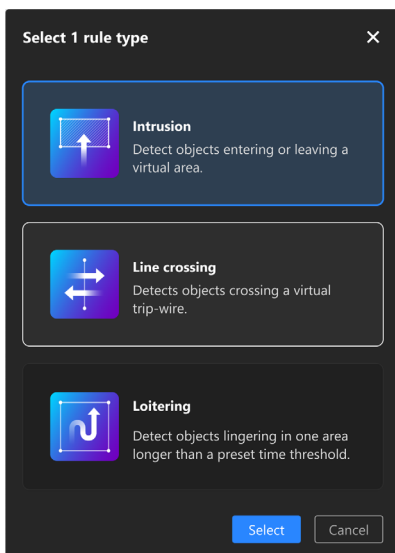

6. Apply object attributes (optional)

Depending on the selected object category:

- **People:** Filter by gender, age group, upper/lower body color. Multiple color selections are allowed; selecting “Any” ignores color filtering.

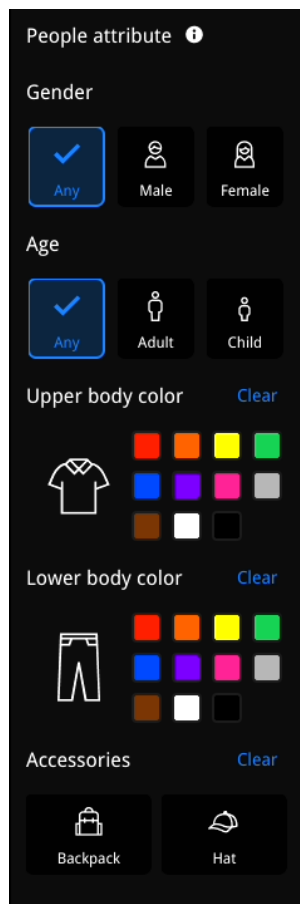

- **Vehicle:** Filter by vehicle type (car, truck, bus, motorcycle, bike) and color. Multiple color selections are allowed; selecting “Any” ignores color filtering.

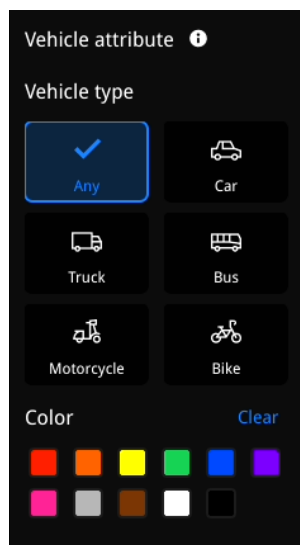

NOTE

Motorcycles and bikes do not support color attributes. They will be excluded from search results when a color filter is applied.

7. Start the search

Click **Search** to begin processing based on the configured parameters.

Viewing and Managing Results

After the search completes, the results page displays:

- **Total results count** at the top.
- A grid of result cards, each showing a thumbnail of the detected object and event time.

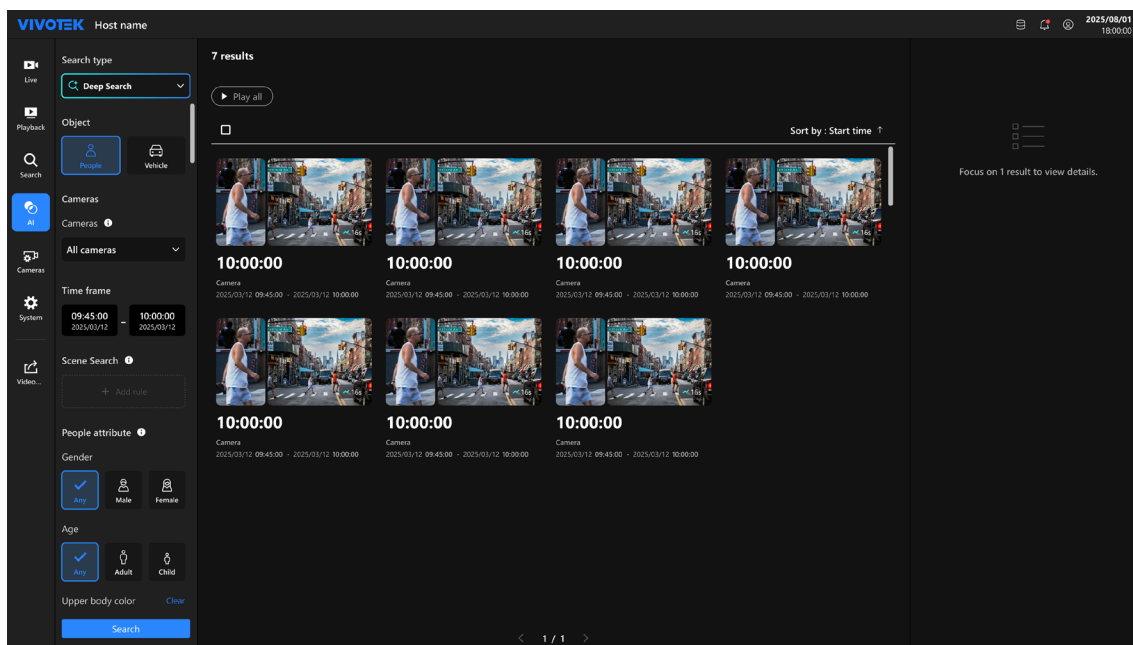

Clicking a result opens the **preview panel** on the right, which includes:

- Playback controls for reviewing the event.
- An object snapshot and event details, including detected time, detected duration, camera name, and time range.
- A **Go to playback** link that opens the Playback page and plays the exact footage.
- An **Export** button for downloading the event clip.

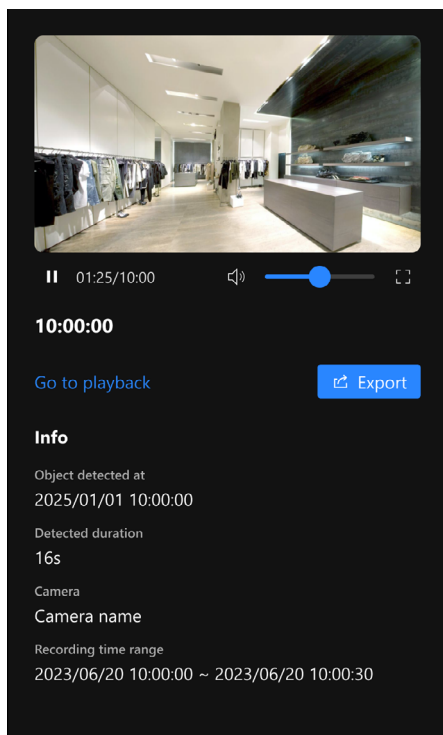

The **Play all** button plays all search results sequentially in the preview panel for continuous review.

Results can be sorted by **trigger time**, in either ascending (A-Z) or descending (Z-A) order. For large result sets, refine the search criteria—such as narrowing the time frame or adjusting detection filters and scene rules—to quickly locate relevant events.

Cameras

The **Cameras** page provides modules for managing all cameras connected to the NVR. It includes options for adding, configuring, and monitoring cameras, as well as adjusting image settings, analytics functions, and firmware updates.

Management

The **Management** page displays a list of all cameras connected to the NVR. It provides options to add new cameras, edit camera settings, and remove cameras. A preview panel on the right shows live video when a camera is selected.

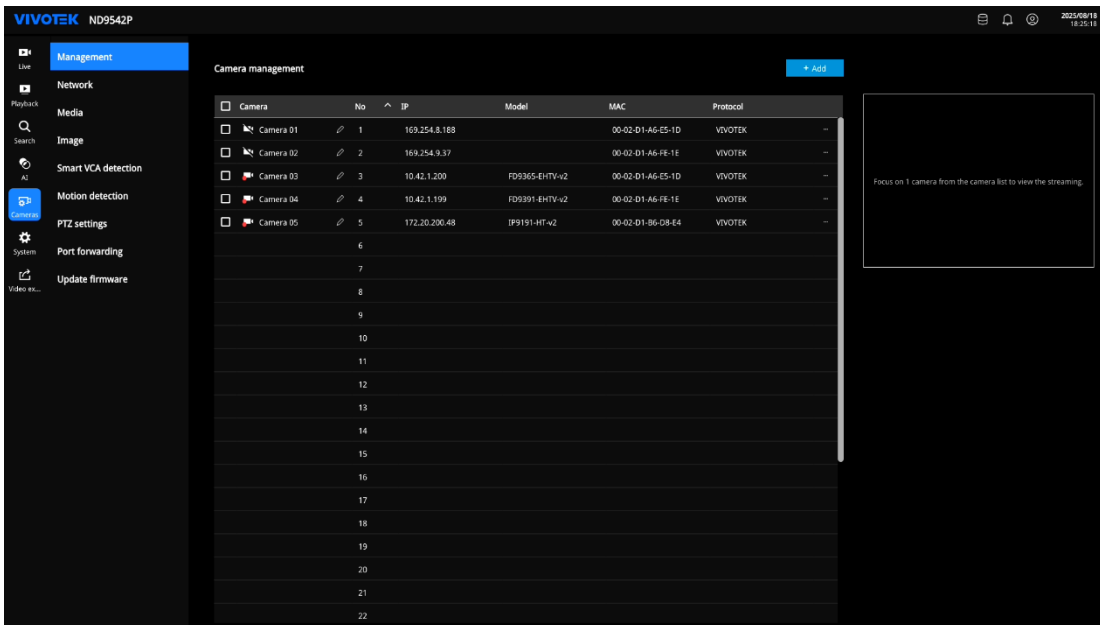

Camera	No	IP	Model	MAC	Protocol
Camera 01	1	169.254.8.188		00-02-01-A6-E5-1D	VIVOTEK
Camera 02	2	169.254.9.37		00-02-01-A6-FF-1E	VIVOTEK
Camera 03	3	10.42.1.200	FD9365-EHTV-v2	00-02-01-A6-E5-1D	VIVOTEK
Camera 04	4	10.42.1.199	FD9391-EHTV-v2	00-02-01-A6-FF-1E	VIVOTEK
Camera 05	5	172.20.200.48	IP9191-HT-v2	00-02-01-86-D8-E4	VIVOTEK
	6				
	7				
	8				
	9				
	10				
	11				
	12				
	13				
	14				
	15				
	16				
	17				
	18				
	19				
	20				
	21				
	22				

Viewing Camera List and Status

The table displays each camera's name, number, IP address, model, MAC address, and protocol.

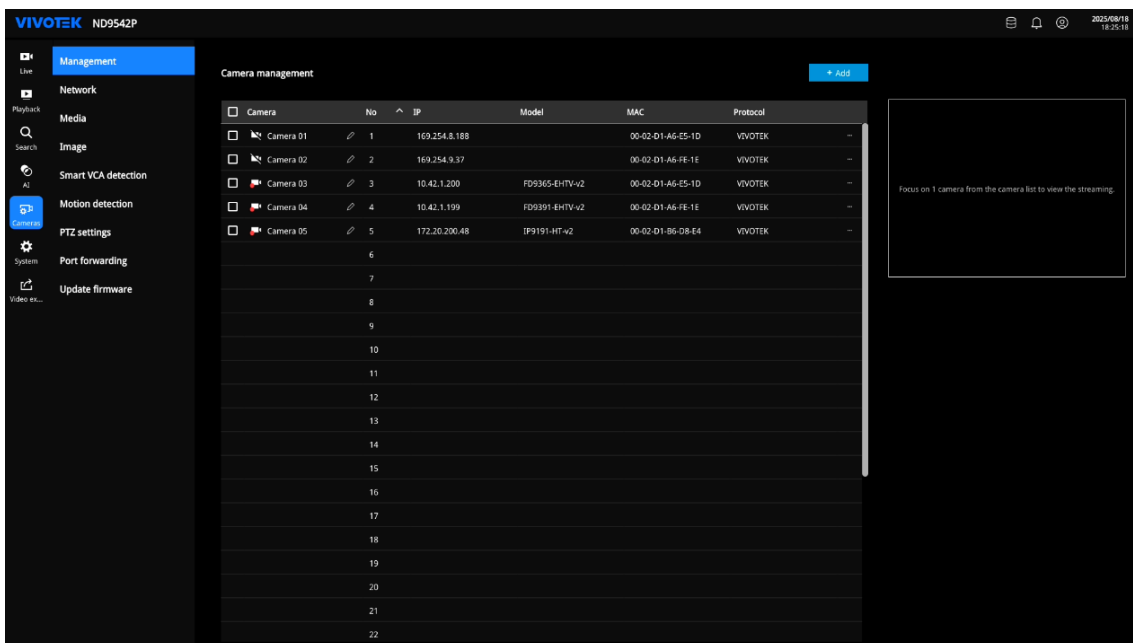



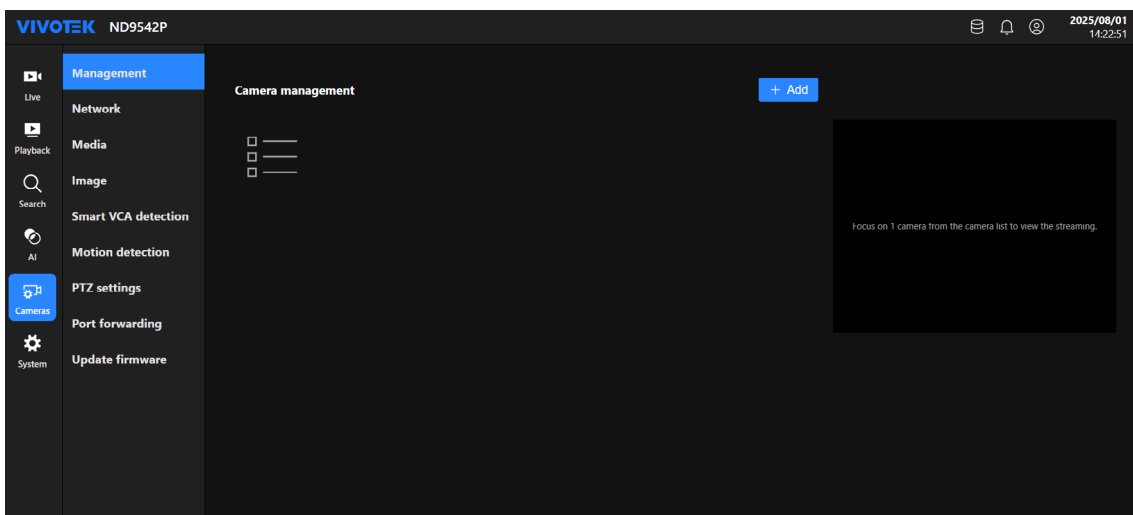



If no cameras are added, the page displays an empty list with an “+ Add” button.



Status icons indicate whether the camera is online, recording, disconnected, or unauthorized. The meaning of each status icon is as follows:

Icon	Meaning
	A standard camera is disconnected and cannot be accessed.
	A standard camera is online and functioning normally.
	A standard camera is online and recording.

	A PTZ (pan-tilt-zoom) camera is online and functioning normally.
	A PTZ camera is online and recording.
	A fisheye camera is online and functioning normally.
	A fisheye camera is online and recording.
	Unauthorized: The camera credentials are incorrect.
	Account locked: The camera account has been locked due to multiple failed login attempts.

Camera Add/Edit

Click **“+ Add”** to open the **Camera Add/Edit** window. In this window, cameras can be added automatically or manually, and existing entries in the list on the right can be edited or deleted.

Searching and Adding Cameras Automatically

When **Camera Add/Edit** opens, the system searches the local network for supported cameras.

1. Select one or more cameras from the discovered list.
2. Click the arrow button to add them to the NVR.
3. Use **Refresh** to repeat the search if the camera does not appear.

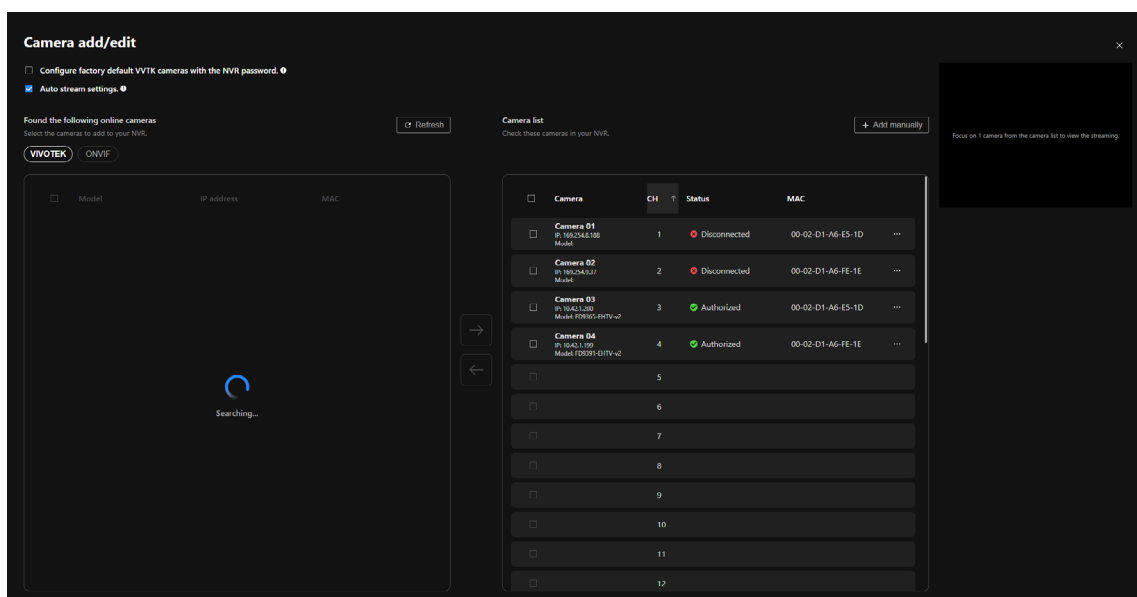

The screenshot shows the 'Camera add/edit' window. On the left, a search progress window is active, displaying 'Searching...' with a circular progress indicator. Below it, there are buttons for 'VIVOTEK' and 'ONVIF'. On the right, the 'Camera list' is displayed, showing a table of discovered cameras with their status and MAC addresses.

Camera	CH	Status	MAC
Camera 01 IP: 192.24.8.108 Model:	1	Disconnected	00-02-D1-A6-E5-1D
Camera 02 IP: 192.24.8.107 Model:	2	Disconnected	00-02-D1-A6-FE-1E
Camera 03 IP: 192.24.8.109 Model: F0905-INTV-v2	3	Authorized	00-02-D1-A6-E5-1D
Camera 04 IP: 192.24.8.108 Model: F0905-INTV-v2	4	Authorized	00-02-D1-A6-FE-1E
	5		
	6		
	7		
	8		
	9		
	10		
	11		
	12		

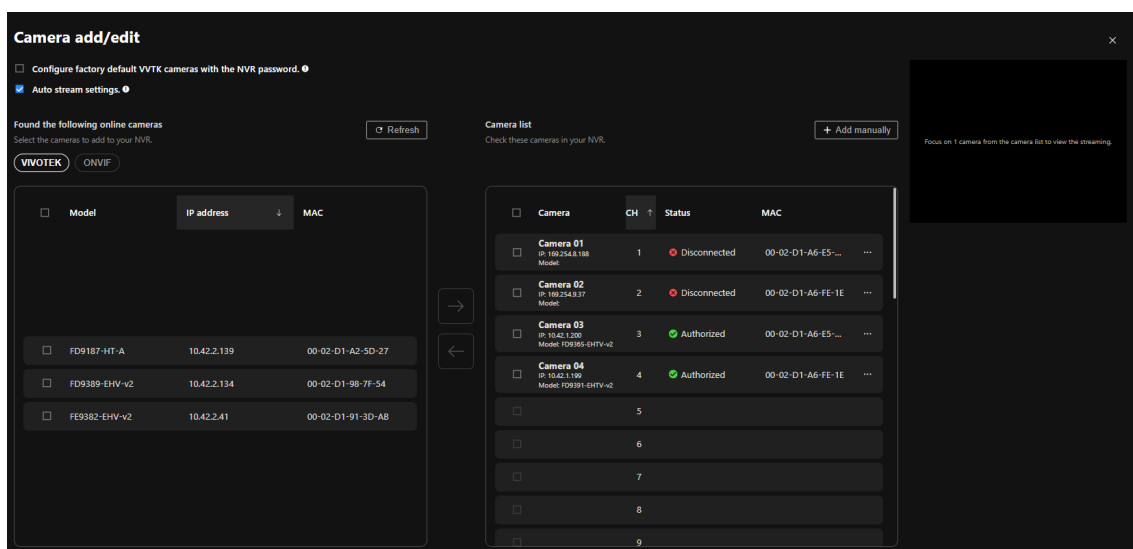

Adding Cameras Manually

If a camera is not discovered automatically:

1. Click **+ Add Manually**.
2. Enter the camera name, IP address, port, username, and password.
3. Select **Apply to All Cameras** if credentials are shared.
4. Click **Save**.

Connection results will show as "Authorized," "Unauthorized," or "Disconnected."

The 'Add manually' dialog box contains the following fields and options:

- Camera name:** Camera 05
- IP:** 10.42.1.199
- Port:** 80
- Protocol:** VIVOTEK
- Username:** Enter user name
- Password:** Enter password
- Apply to all cameras
- Buttons:** Save, Cancel

Editing Camera Information

Camera information can be edited from either the **Management** page or the **Camera Add/Edit** page. The editing procedure and available options are identical regardless of where the action is performed.

To edit camera information:

1. Locate the camera entry in the list.
2. Click the **More (...)** icon to open the menu.
3. Select **Edit** to open the **Edit Camera** window.
4. Modify settings such as camera name, binding type, IP address, port, user credentials, or password.
5. Click **Save** to apply the changes.

Edit camera [X]

Camera name
Camera 01

Binding
MAC

IP: 169.254.8.188 Port: 80

Protocol: VIVOTEK Camera channel: 1

Model: 00-02-D1-A6-E5-1D
MAC: 00-02-D1-A6-E5-1D

Username
Enter user name

Password
Enter password [eye icon]
Change password

Apply to all cameras

[Save] [Cancel]

Deleting Cameras

A camera can be removed from either the Management page or the Camera Add/Edit page. The deletion procedure is the same for both locations.

To delete a camera:

1. Locate the camera entry in the list.
2. Click the **More (...)** icon to open the menu.
3. Select **Delete** and confirm the deletion.

Removing a camera deletes its configuration from the NVR but does not erase previously recorded video.

<input type="checkbox"/>	Camera	CH	Status	MAC	
<input type="checkbox"/>	Camera 01 IP: 169.254.8.188 Model:	1	Disconnected	00-02-D1-A6-E5-1D	...
<input type="checkbox"/>	Camera 02 IP: 169.254.9.37 Model:	2	Disconnected	00-02-D1-A	Edit Delete
<input type="checkbox"/>	Camera 03 IP: 10.42.1.200 Model: FD9365-EHTV-v2	3	Authorized	00-02-D1-A6-E5-1D	...
<input type="checkbox"/>	Camera 04 IP: 10.42.1.199 Model: FD9391-EHTV-v2	4	Authorized	00-02-D1-A6-FE-1E	...

Factory Default Camera Password Setup

The **Set password** option appears in the following camera-addition workflows. Cameras in the factory-default state require a password to be created during the addition process before they can operate normally in Live view, Playback, and management functions.

Initial Setup

When adding cameras through the initial setup process, factory default cameras appear in the camera list with a **Set password** status.

1. In the camera list, locate the camera marked **Set password**.

The screenshot shows the 'Add cameras' workflow in the VIVOTEK ND9442P interface. On the left, a sidebar lists setup steps: Name & Language, Admin account setup, Network, Time, Cloud service, Add cameras (selected), and Recording. The main area is divided into two panels. The 'Add cameras' panel shows a table of found online cameras:

<input type="checkbox"/>	Model	IP address	Mac
<input type="checkbox"/>	SD9191	192.168.1.12	00-00-00-00-00-00
<input checked="" type="checkbox"/>	SD9191	192.168.1.12	00-00-00-00-00-00
<input checked="" type="checkbox"/>	SD9191	192.168.1.12	00-00-00-00-00-00
<input type="checkbox"/>	SD9191	192.168.1.12	00-00-00-00-00-00
<input type="checkbox"/>	SD9191	192.168.1.12	00-00-00-00-00-00

The 'Camera list' panel shows a table of cameras in the NVR:

<input type="checkbox"/>	Camera	CH	Status	Mac	
<input type="checkbox"/>	Camera 01 IP: 11.1.1.1 Model: SD9191	1	Authorized	00-00-00-00-00-00	...
<input type="checkbox"/>	Camera 02 IP: 11.1.1.1 Model: SD9191	2	Authorized	00-00-00-00-00-00	...
<input type="checkbox"/>	Camera 03 IP: 11.1.1.1 Model: SD9191	3	Unauthorized	00-00-00-00-00-00	...
<input type="checkbox"/>	Camera 04 IP: 11.1.1.1 Model: SD9191	5	Set password	00-00-00-00-00-00	...
<input type="checkbox"/>	Camera 05 IP: 11.1.1.1 Model: SD9191	6	Authorized	00-00-00-00-00-00	...

At the bottom, there are 'Back' and 'Next' buttons.

2. Select **Set password** to open the password setup dialog.

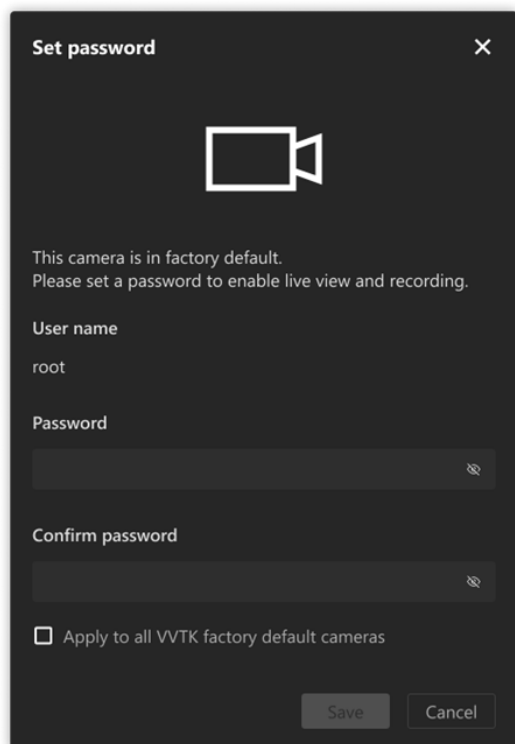

3. Enter password and confirm password.
4. (Optional) Enable **Apply to all VVTK factory default cameras** to apply the same password to all default cameras.
5. Select **Save** to apply the password.

Camera Management

In **Cameras > Management**, when a factory default camera is detected, **Set password** is displayed in the Status column.

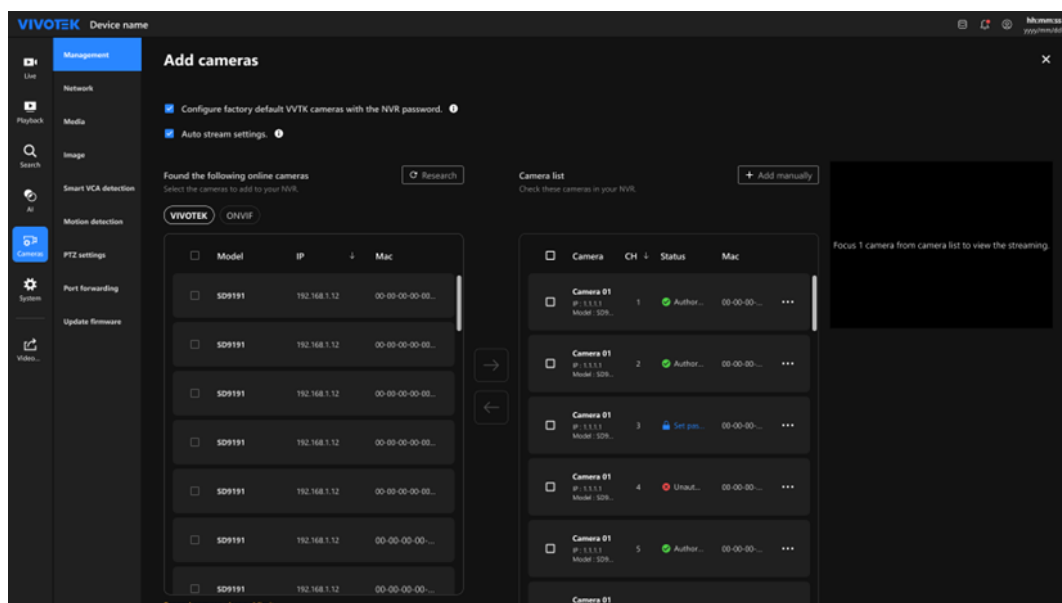

1. Select **Set password** to open the password setup dialog.

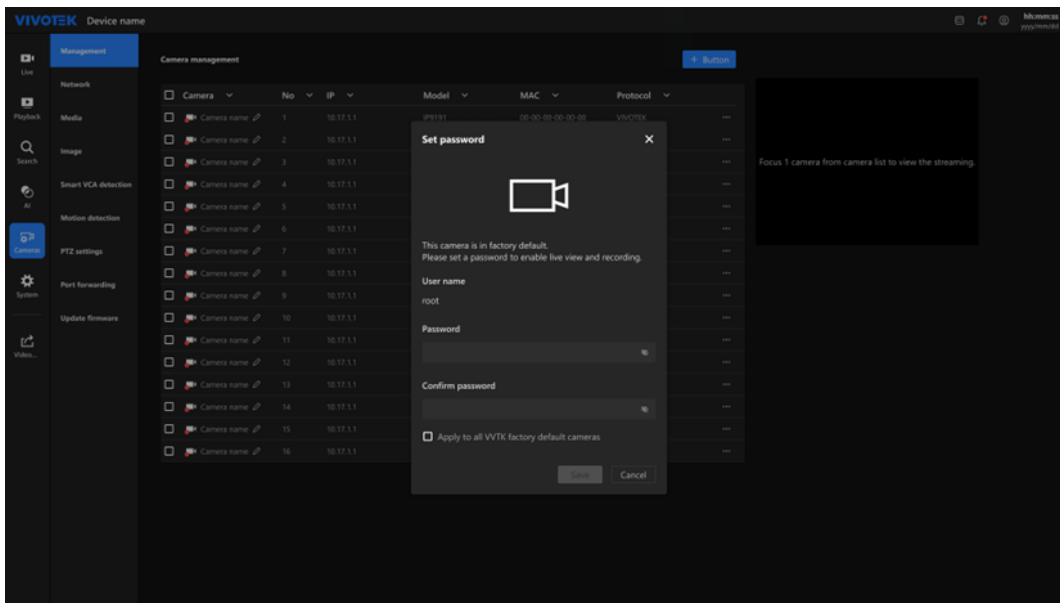

2. Enter password and confirm password.
3. (Optional) Enable **Apply to all VVTK factory default cameras** to apply the same password to all default cameras.
4. Select **Save** to apply the password.

Automatic Camera Addition (PoE Connection)

When a factory default camera is automatically added through a PoE connection, the **Set password** option appears in two locations:

- **Cameras > Management**

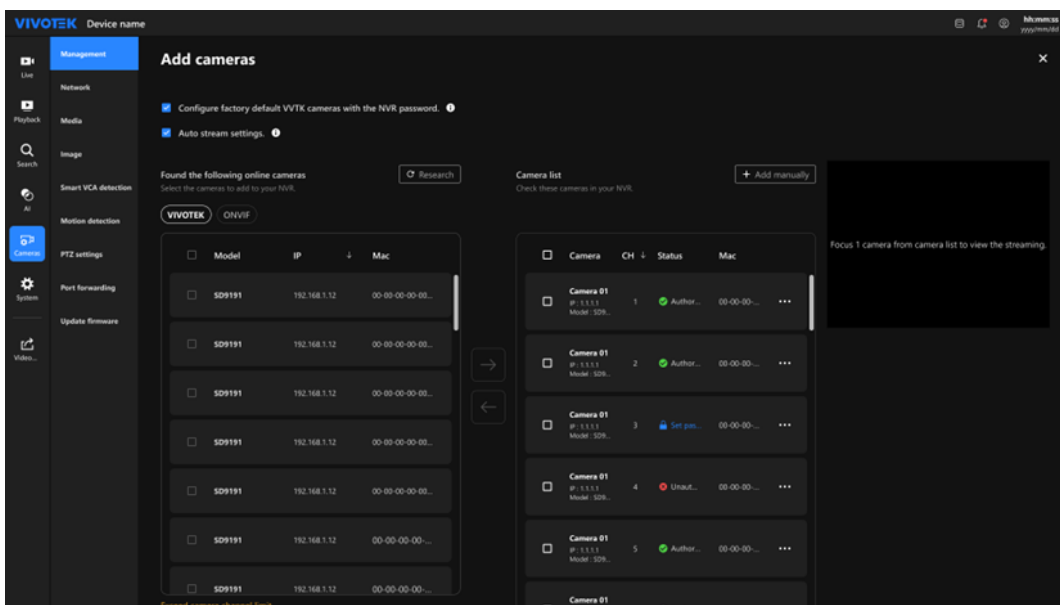

- Live view

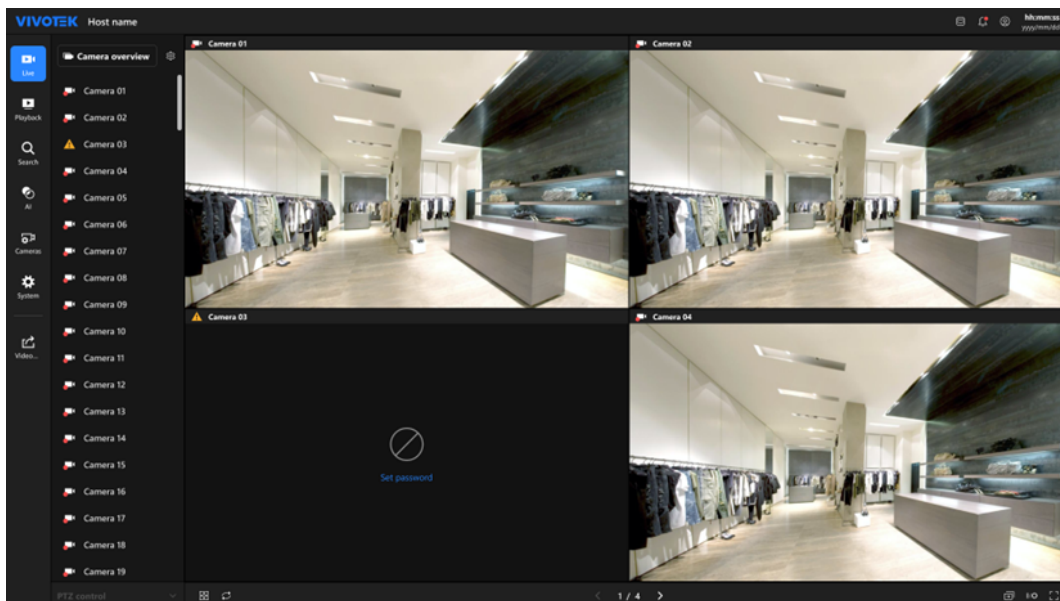

1. Select **Set password** from either the Camera list or the Live view prompt to open the password setup dialog.

Set password
✕



This camera is in factory default.
Please set a password to enable live view and recording.

User name

root

Password

Confirm password

Apply to all VVTK factory default cameras

Save
Cancel

2. Enter **Password** and **Confirm password**.
3. (Optional) Enable **Apply to all VVTK factory default cameras** to apply the same password to all default cameras.
4. Select **Save** to apply the password.

Focusing and Previewing Camera Streams

Clicking a camera focuses on it and displays its video in the preview panel. Only one camera can be focused at a time. VIVOTEK cameras support live preview directly, while ONVIF or RTSP cameras show connection information only.

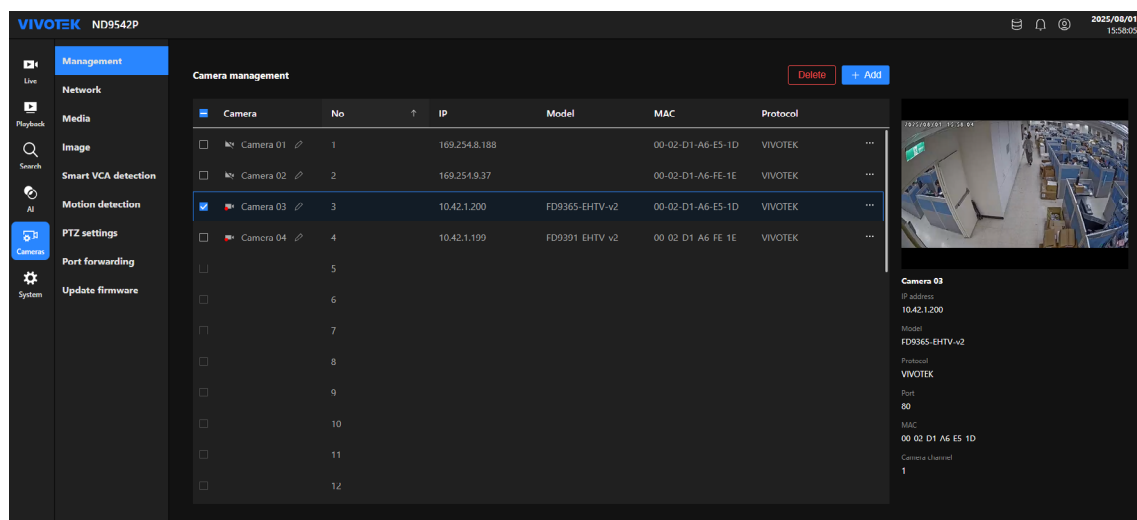

The preview panel contains:

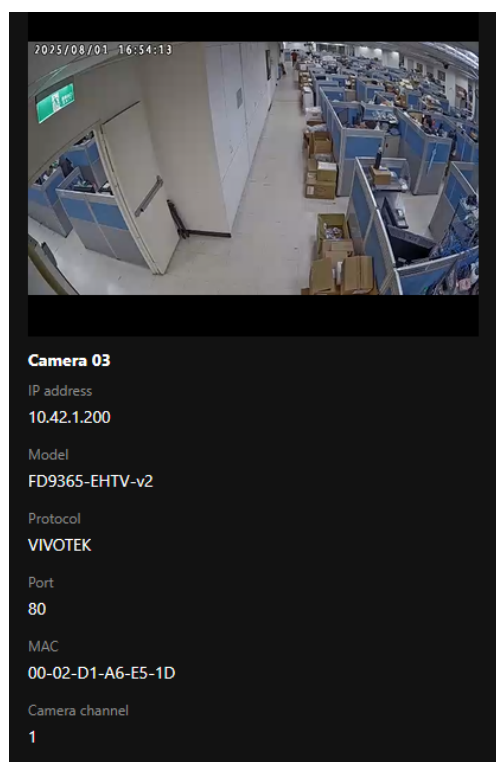

- The camera name (as shown in the list).
- The camera information including IP address, model, protocol, port, MAC address, and camera channel.
- A preview area for live video.



When a camera is selected:

- While connecting, the preview area shows a loading animation.
- After a successful connection, the live video is displayed.

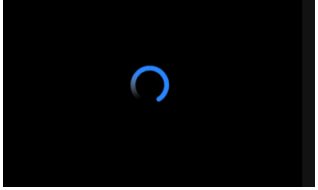
- If the connection fails, the preview area displays Camera disconnected.

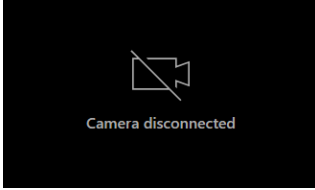
Loading	Connected	Disconnected
		

Network

The Network page allows configuration of individual camera network settings. Use this page to set IP addressing, ports, and other related parameters for each camera connected to the NVR.

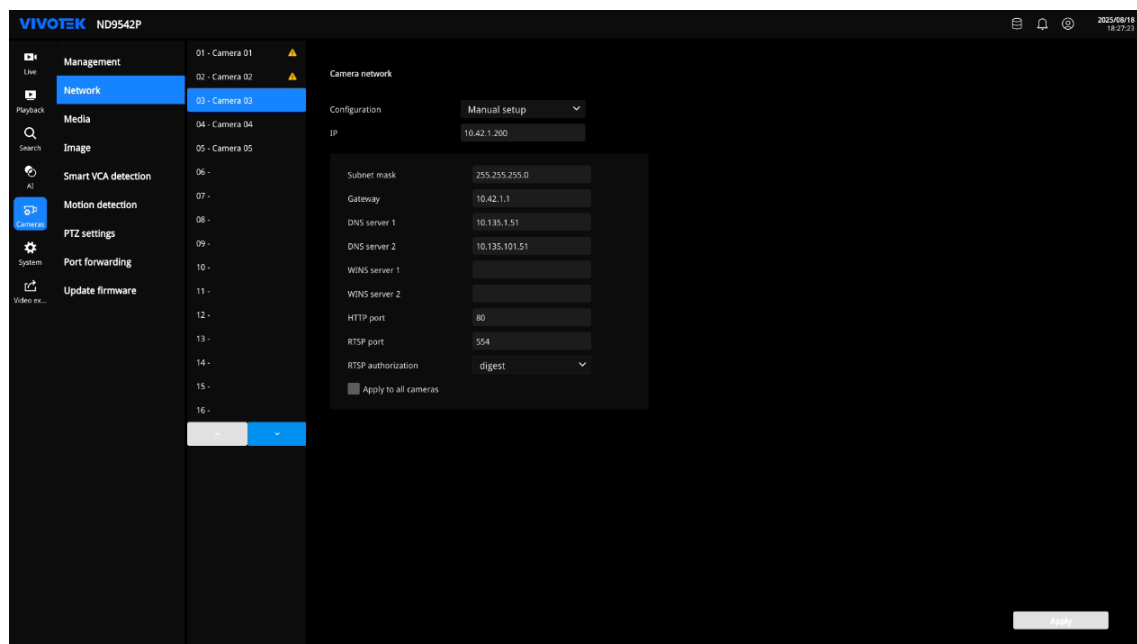

If a camera is disconnected, the right panel displays a warning message: “[Camera Name] is disconnected. Check your connection and try again.”

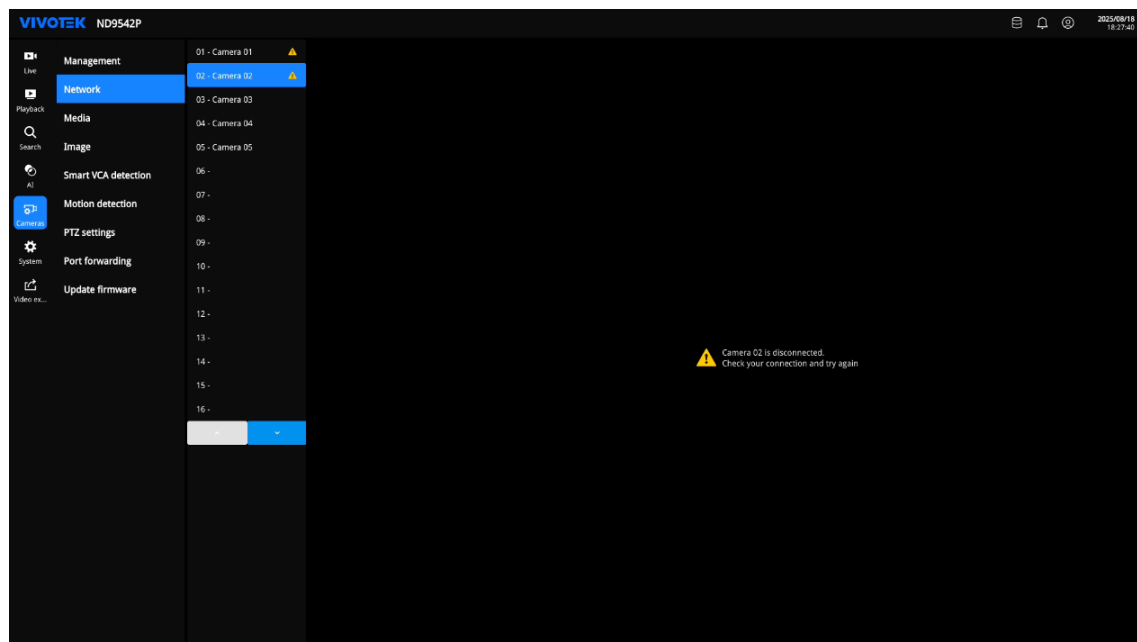

Camera Network Settings

Select a camera from the list on the left to configure its network parameters. The Configuration option provides two modes:

- **DHCP:** Obtain network settings automatically from the network. In this mode, HTTP port, RTSP port, and RTSP authorization can still be modified manually.

- **Manual setup:** Enter network parameters manually.

When “Manual setup” is selected, the following settings can be configured:

- **IP:** The camera’s IP address
- **Subnet mask:** Subnet mask for the camera network
- **Gateway:** Default gateway address
- **DNS server 1 / DNS server 2:** DNS server addresses
- **WINS server 1 / WINS server 2:** WINS server addresses if required by the network
- **HTTP port:** Port number for HTTP connections
- **RTSP port:** Port number for RTSP streaming
- **RTSP authorization:** Authentication method for RTSP connections
- **Apply to all cameras:** Apply the same settings to all connected cameras

After making changes, click Apply to save the configuration.

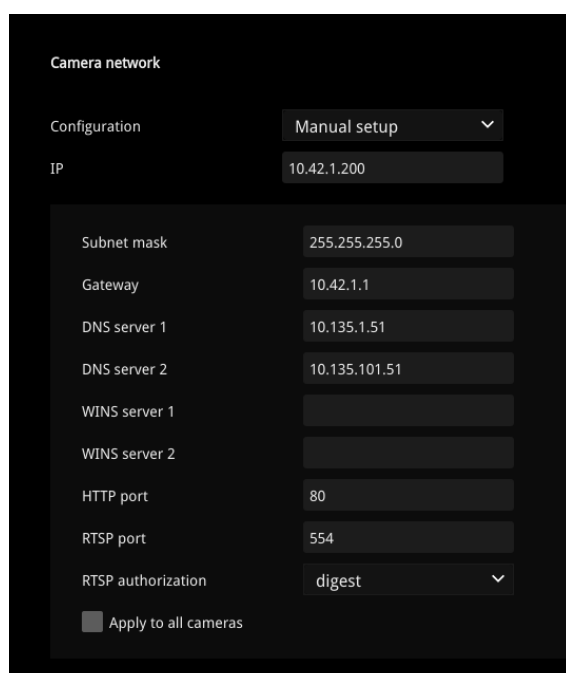

The screenshot displays the 'Camera network' configuration window. At the top, the title is 'Camera network'. Below it, there is a 'Configuration' dropdown menu set to 'Manual setup'. The main area contains several input fields for network parameters:

Parameter	Value
IP	10.42.1.200
Subnet mask	255.255.255.0
Gateway	10.42.1.1
DNS server 1	10.135.1.51
DNS server 2	10.135.101.51
WINS server 1	
WINS server 2	
HTTP port	80
RTSP port	554
RTSP authorization	digest

At the bottom left, there is a checkbox labeled 'Apply to all cameras' which is currently unchecked.

Media

The Media page is used to configure video and audio streaming parameters for each connected camera. These settings allow adjustment of image quality, frame rate, and compression methods to balance bandwidth usage, storage requirements, and video clarity according to surveillance needs.

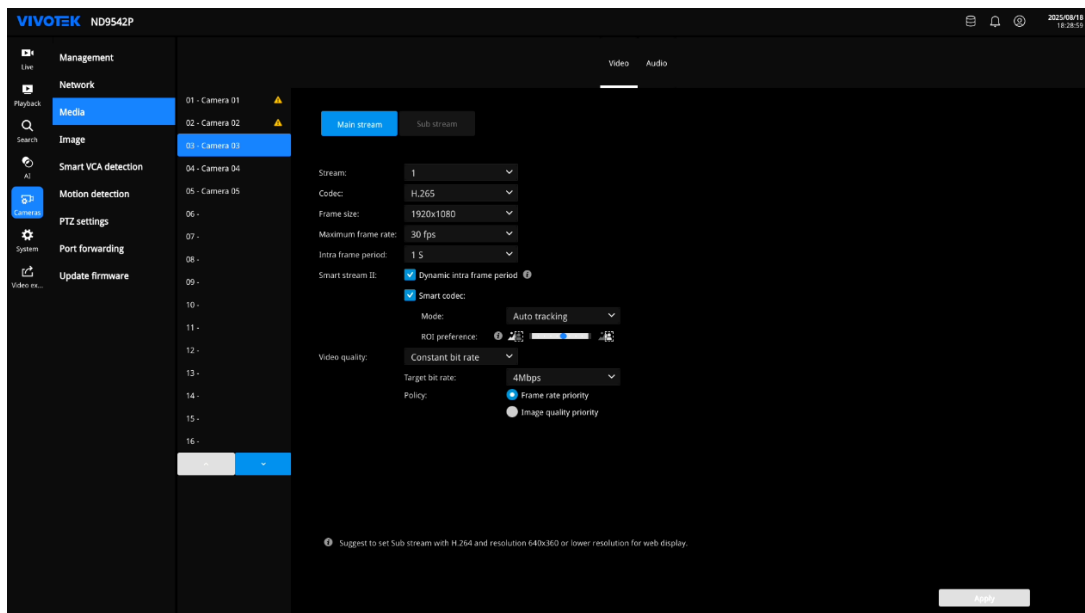

Video

The Video page allows configuring video output for each camera, including stream format, resolution, frame rate, and encoding options. Both **Main stream** and **Sub stream** can be configured separately to meet requirements for quality, bandwidth, and storage.

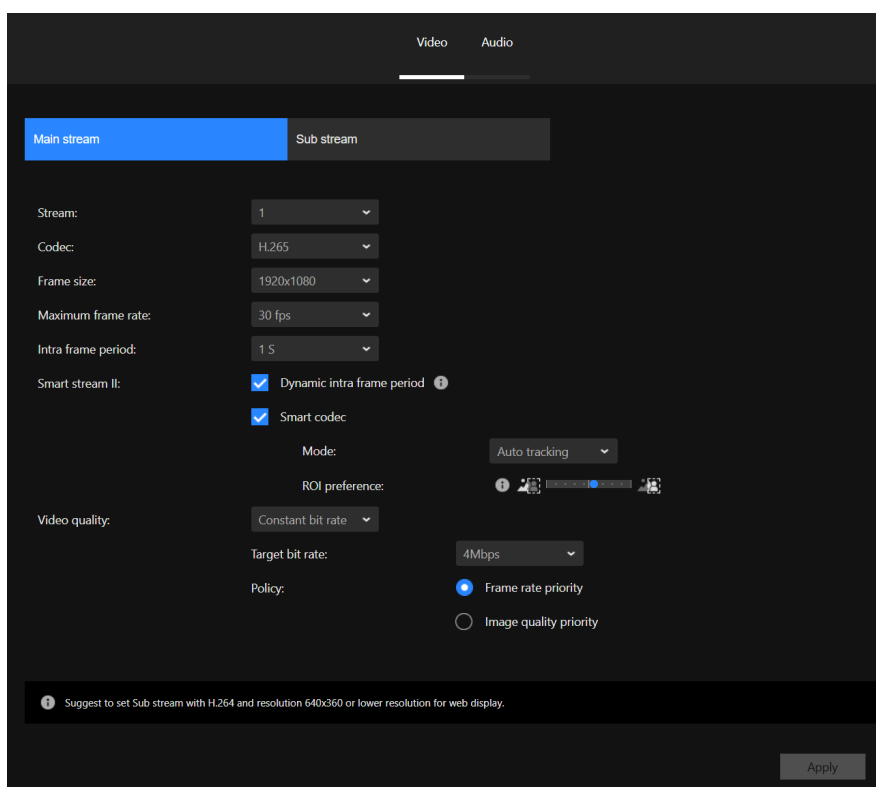

The configurable items include:

Stream

Select the stream profile to be used for the current Main stream or Sub stream. Each profile can have different codec, resolution, frame rate, and quality settings.

Codec

Choose the compression format:

- **MJPEG** – Provides the highest image quality, requires ample bandwidth.
- **H.264** – Balanced option for dynamic scenes with stable bandwidth.
- **H.265** – High efficiency for high-resolution video or limited bandwidth.

Frame Size and Maximum Frame Rate

Choose the resolution and maximum frame rate. Higher resolution and frame rate provide clearer and smoother video but require more bandwidth and storage.

Intra Frame Period

Defines how often I-frames are inserted into the stream. Shorter intervals produce better video quality but require more bandwidth. Recommended settings based on use cases:

High-Frequency Frame Updates (e.g., AI-assisted detection, frame-level analysis)	1/2 or 1/4 second	Increases I-Frame frequency for enhanced temporal resolution, suitable for scenarios requiring precise frame analysis or low-latency processing.
High-Dynamic Scenarios (e.g., Traffic Monitoring)	1 second	Quickly generates complete frames, suitable for capturing fast-moving targets.
General Surveillance (e.g., Offices, Stores)	2 seconds	Balances video clarity, bandwidth, and storage usage, ideal for most daily surveillance scenarios.
Static Scenarios (e.g., Warehouses)	3 or 4 seconds	Reduces the number of I-Frames to save resources, suitable for low-variation scenes.
Remote or Low-Bandwidth Monitoring	1-2 seconds	For unstable or limited networks, keep the interval short (1 or 2 seconds) so that if packets are lost, the next I-frame quickly restores the image.

Smart Stream II

Smart Stream II optimizes bandwidth and storage usage.

- **Dynamic intra frame period:** Automatically adjusts the I-frame interval between 1 and 10 seconds depending on scene activity.
- **Smart codec:** Applies advanced compression, reducing bandwidth usage in static areas while keeping detail in areas with motion.
- **Mode:** Select Auto tracking, Manual, or Hybrid to manage Region of Interest (ROI).
- **ROI preference:** ROI (Region of Interest) lets the camera allocate higher image quality to key areas within the video frame. Use the slider to adjust how much image quality is concentrated in ROI areas compared to the rest of the scene:
 - Move the slider to the **right:** Increase quality in ROI areas (such as entrances, faces, license plates) while lowering quality in non-ROI areas to save bandwidth.
 - Move the slider to the **left:** Keep more quality in the background (non-ROI areas) and reduce the difference between ROI and non-ROI.
 - The center position balances quality evenly across the entire image.

Video Quality and Bit Rate

This section defines how the camera controls video data flow, balancing image quality and bandwidth usage. Users can choose between two modes—**constant bit rate** and **fixed quality**.

- **Constant bit rate**

In this mode, the camera transmits video at a fixed bit rate.

Target bit rate specifies the data rate to be used. Higher bit rates produce clearer images but require more bandwidth and storage.

When bandwidth becomes limited, **Policy** determines which factor to prioritize:

frame rate priority maintains the configured frame rate by lowering image quality, while **image quality priority** maintains image clarity but may reduce the frame rate.

- **Fixed quality**

In this mode, the camera maintains a consistent image quality and adjusts the bit rate automatically as needed. The desired **quality level** can be selected from Medium, Standard, Good, Detailed, or Excellent, and a **maximum bit rate** can be specified to limit bandwidth usage. When network traffic increases, the bit rate fluctuates to keep image quality stable, but it will not exceed the configured maximum.

Recommendations: Use **constant bit rate** when bandwidth and storage resources must be tightly controlled, such as in multi-camera environments. Choose **fixed quality** when maintaining image clarity is more important than minimizing bandwidth, such as for critical monitoring areas.

Click **Apply** to save changes.

Audio

This Audio page allows configuration of audio output for each camera, including codec selection and microphone input levels.

Mute

Enable or disable audio transmission from the camera. When muted, audio will be excluded from video recordings, regardless of microphone or codec settings.

Audio Type

Select the desired audio codec format. Available options vary in compression efficiency, sound quality, and bandwidth usage:

- **AAC**

Provides high-quality audio with efficient compression. Suitable for environments requiring clear sound with minimal distortion.

Bit rate options: 16K to 128Kbps. Higher bit rates deliver better clarity but consume more bandwidth.

- **G.711**

A standard codec for real-time audio, delivering good quality with minimal compression. Fixed bit rate at 64Kbps.

Sampling codec options:

- **pcmu** – Common in North America and Japan, optimized for voice clarity.

- **pcma** – Common in Europe, compatible with regional telecom standards.

- **G.726**

A codec offering moderate compression, balancing audio quality and bandwidth efficiency.

Bit rate options: 16K, 24K, 32K, and 40Kbps. Lower bit rates reduce bandwidth usage but may affect clarity.

Microphone Input Gain

Adjusts audio input levels separately for internal and external microphones. Use the sliders to increase or decrease microphone sensitivity based on the environment.

Image

This section provides configuration options to adjust video display parameters for each camera channel. It allows operators to fine-tune image visibility, orientation, and basic day/night behaviors.

Display

The **Display** tab includes settings related to image naming, color display mode, orientation, and light response.

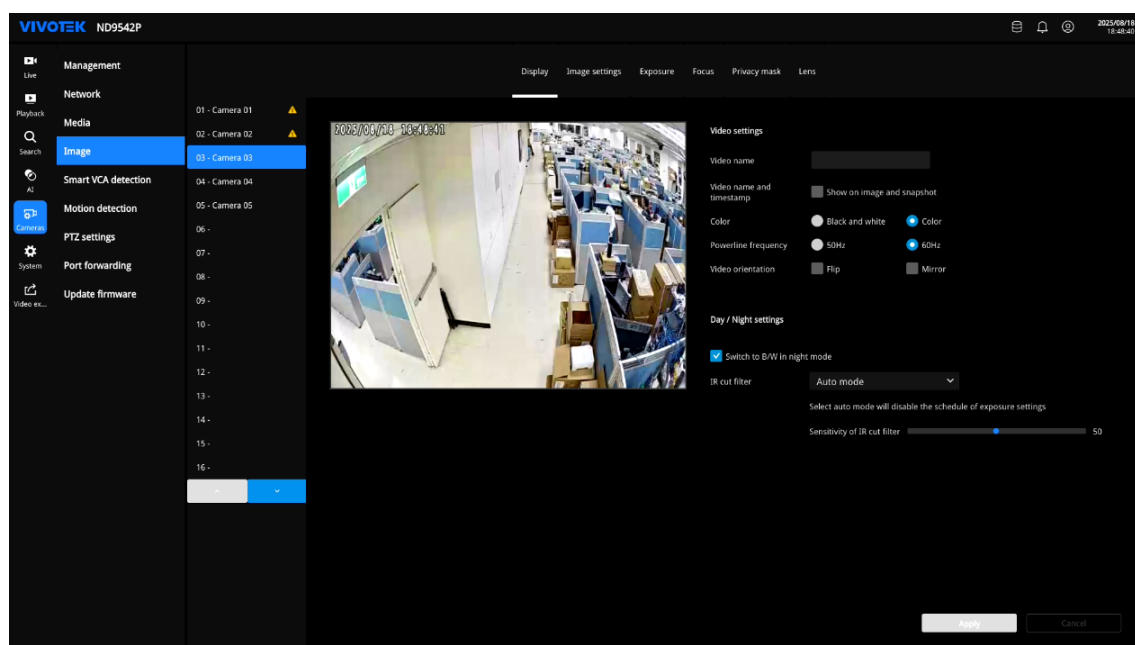

Video Settings

- **Video name:** Defines a custom name for the camera video stream. This label is optional.
- **Video name and timestamp:** Enables overlay of the video name and timestamp on both live view and snapshots.
- **Color:** Choose between Color and Black and white display modes.
- **Powerline frequency:** Select the frequency standard based on the local power grid to reduce flickering. Options include 50Hz and 60Hz.
- **Video orientation:**
 - Flip: Vertically flips the video image.
 - Mirror: Horizontally mirrors the image.

Day / Night Settings

- **Switch to B/W in night mode:** When enabled, the camera automatically switches to black-and-white mode in low-light conditions to improve clarity.
- **IR cut filter:** Defines the behavior of the IR cut filter. Available modes include:
 - Auto mode: Switches between day and night modes based on ambient light.
 - Day mode: IR cut filter remains engaged to provide accurate color reproduction.
 - Night mode: IR cut filter is disengaged to improve sensitivity in darkness.
 - Schedule mode: Switches modes based on a predefined schedule.
 - Synchronize with digital input: IR cut behavior is triggered by digital input signals.
- **Light sensor sensitivity:** Adjusts how sensitive the system is to changes in lighting, affecting when transitions between day and night modes occur. Default value is 50.

Click **Apply** to save changes or **Cancel** to discard them.

Image Settings

Image Settings provides controls to fine-tune image quality parameters such as brightness, contrast, white balance, and noise reduction. Settings can be applied in either **Main** mode (default) or **Scheduled** mode (based on time or lighting conditions).

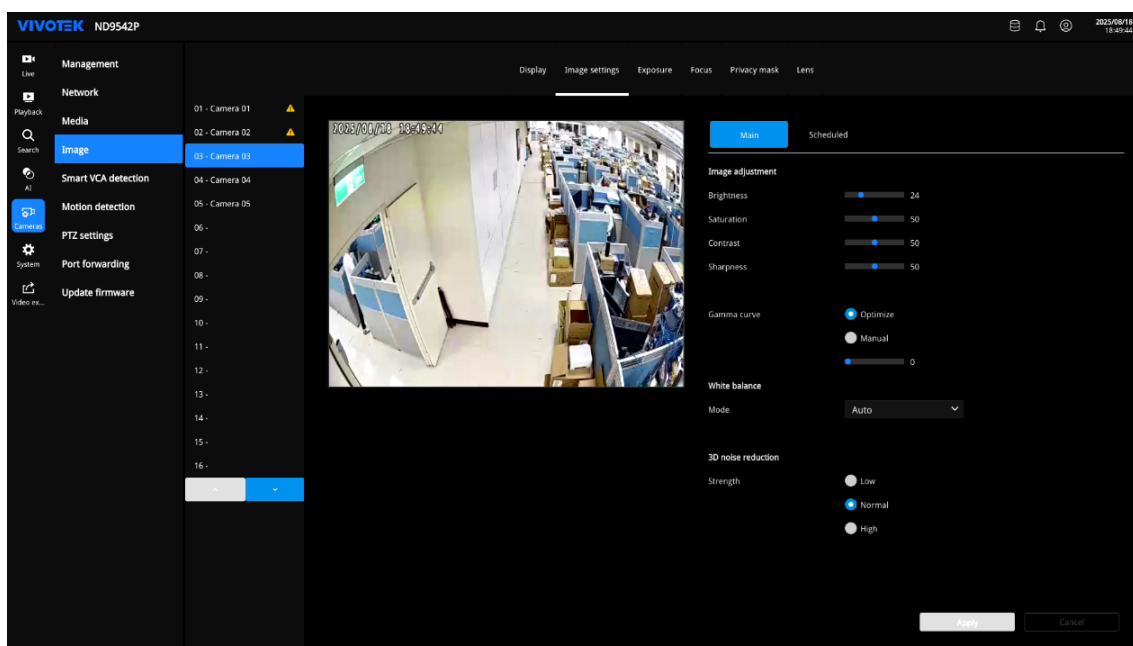

Image Adjustment

Adjust visual parameters to enhance image clarity and detail. These settings are available in both Main and Scheduled modes.

- **Brightness:** Adjusts the overall light intensity of the image.
- **Saturation:** Controls the intensity of image colors.
- **Contrast:** Modifies the difference between dark and light areas.
- **Sharpness:** Enhances edge definition and detail clarity.

- **Gamma curve:**
 - Optimize: Uses the system-recommended gamma curve for general scenarios.
 - Manual: Allows manual adjustment via the gamma slider.

White Balance

Controls how the system compensates for different lighting temperatures.

- **Auto:** Automatically adjusts white balance based on current lighting conditions.
- **Fixed current:** Locks the white balance at the current levels.
- **Manual:** Enables manual white balance adjustment (setting not shown in current view).

3D Noise Reduction

Reduces background noise, especially under low-light conditions.

- **Strength:** Choose from Low, Normal, or High.

To apply different settings based on time or lighting conditions, enable the Scheduled option.

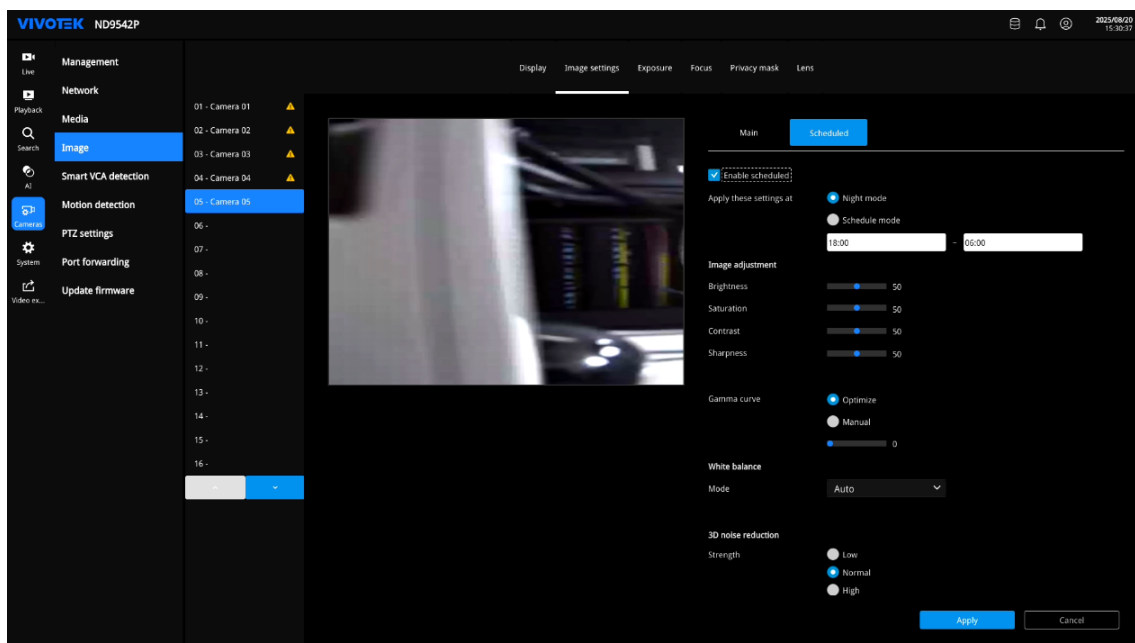

- **Enable scheduled:** Activates scheduled image profiles.
- **Apply these settings at:**
 - Night mode: Applies settings automatically when night conditions are detected.
 - Schedule mode: Applies settings based on a specified time range (e.g., 18:00–06:00).

Scheduling Options

When scheduling is enabled, all image adjustments, white balance, and noise reduction values can be configured independently for the scheduled profile.

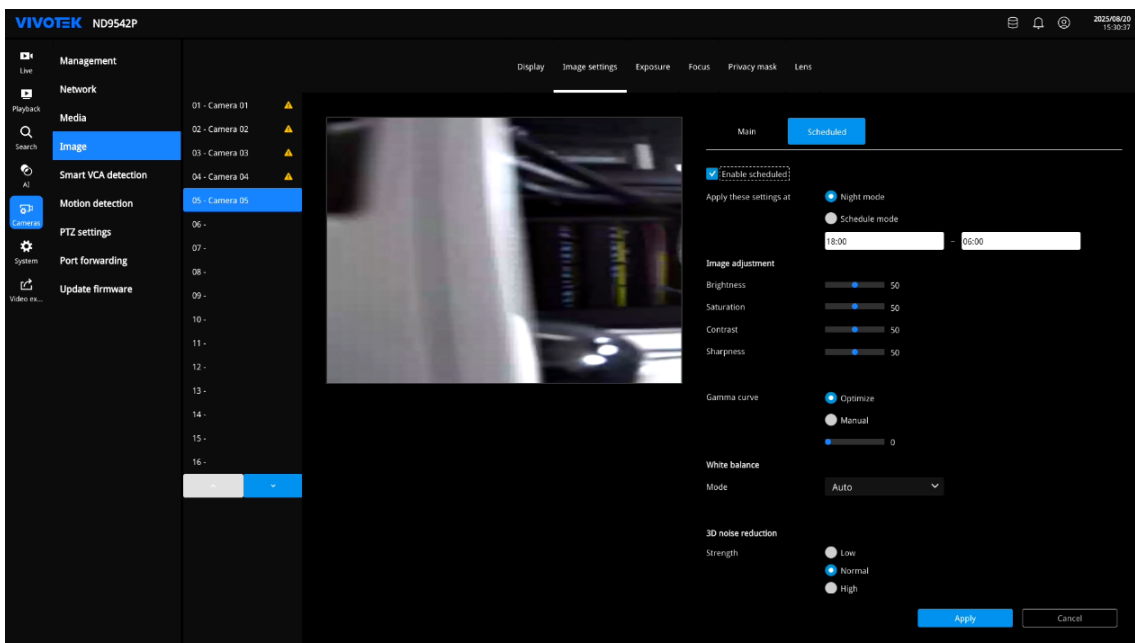

Click **Apply** to save changes or **Cancel** to discard them.

Exposure

Exposure provides controls to adjust how the camera handles lighting in various environments. Settings include exposure window strategy, exposure compensation, and wide dynamic range (WDR) functions. These configurations are available in both Main and Scheduled modes.

Exposure Strategy

Determines how the system evaluates brightness in the image when calculating exposure.

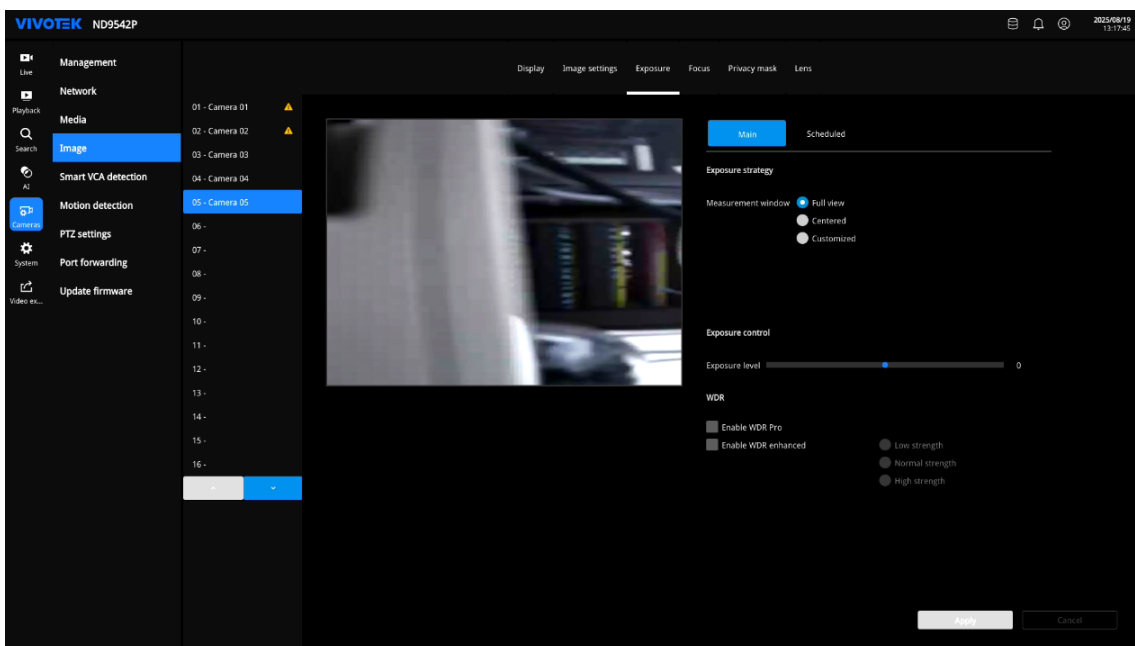

- **Measurement window:** Defines the target area used for exposure metering.
 - **Full view:** Uses the entire scene.
 - **Centered:** Focuses on the central region of the image.
 - **Customized:** Allows manual placement of measurement zones.

When **Customized** is selected, up to 10 exposure windows can be drawn on the preview area.

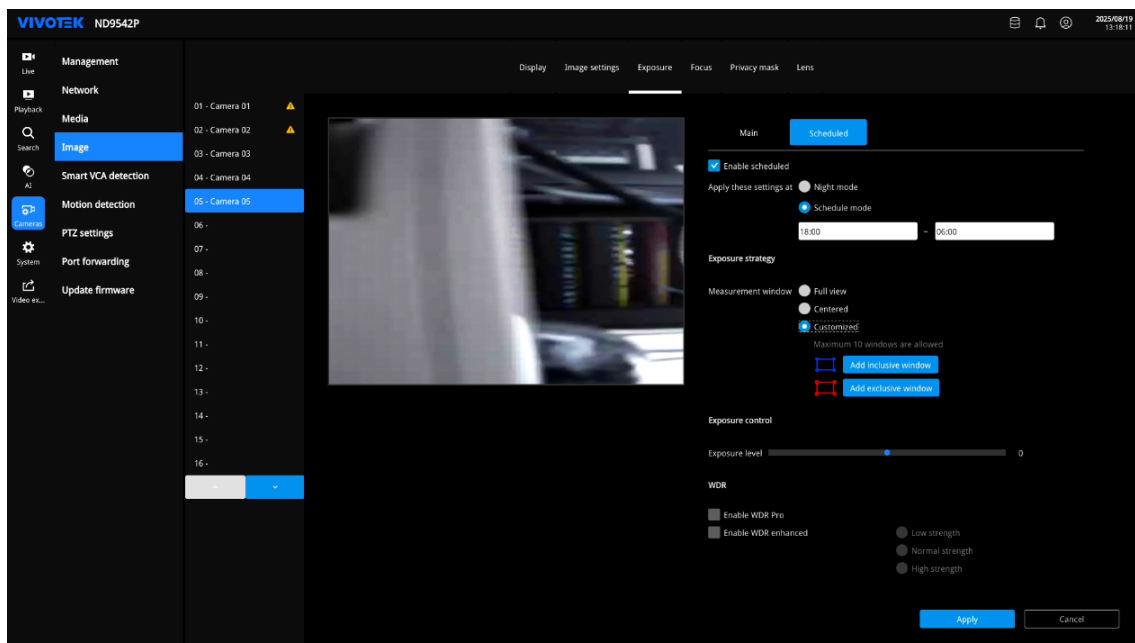

- **Add inclusive window:** Includes the selected area for exposure calculation.
- **Add exclusive window:** Excludes the selected area from exposure calculation.

Exposure Control

Manually adjusts the overall exposure level to make the image brighter or darker.

- **Exposure level:** Range from -0.7 to +0.7.

WDR

WDR (Wide Dynamic Range) improves visibility in scenes with both bright and dark regions.

- **Enable WDR Pro:** Activates the advanced WDR function to preserve detail in high-contrast areas.
- **Enable WDR enhanced:** Adds further processing to improve WDR quality.
 - **Low strength**
 - **Normal strength**
 - **High strength**

Click **Apply** to save all changes, or **Cancel** to discard them.

Scheduling Options

When using **Scheduled** mode, exposure settings can be applied automatically based on time or lighting conditions.

- **Enable scheduled:** Activates time-based exposure profiles.
- **Apply these settings at:**
 - **Night mode:** Automatically applies settings during low-light conditions.
 - **Schedule mode:** Applies settings during the specified time range (e.g., 18:00–06:00).

Click **Apply** to save changes or **Cancel** to discard them.

Focus

Focus provides tools for adjusting the camera's focus and zoom. This function is typically available on models equipped with motorized lens modules. The adjustment process involves three steps: activating the iris, performing focus or zoom operations, and finalizing iris settings.

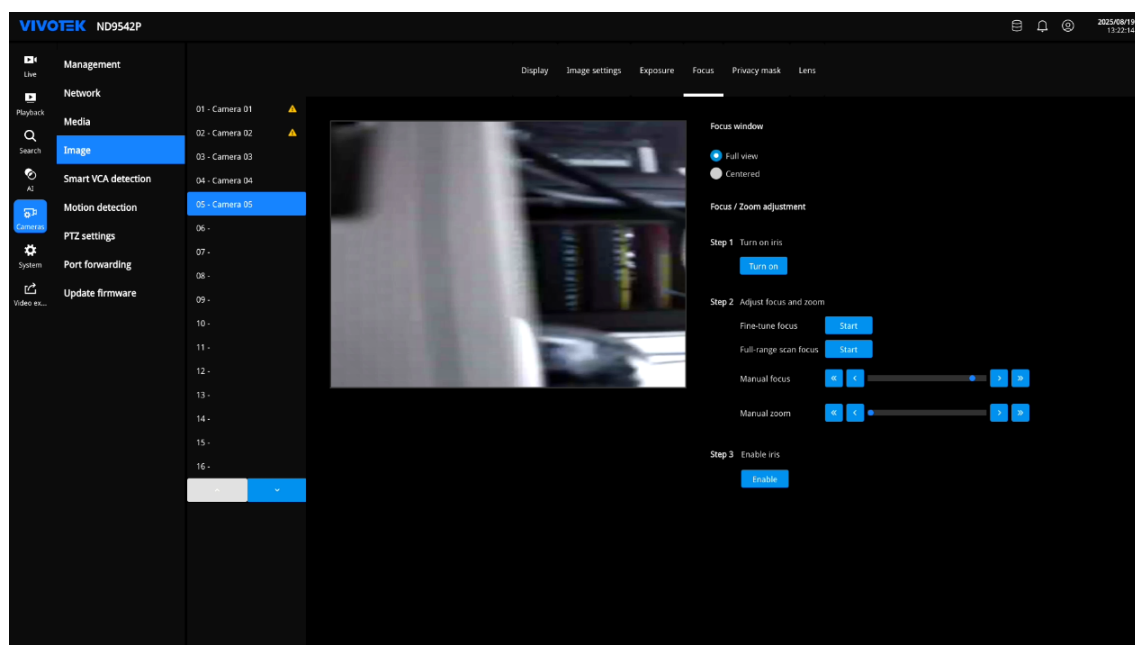

Focus Window

Defines the area of the image used for focus calculation.

- **Full view:** Uses the entire image area for focus measurement.
- **Centered:** Uses only the central portion of the image.

Focus / Zoom Adjustment

Provides manual and semi-automatic tools to assist in adjusting lens focus and zoom.

- **Step 1 – Turn on iris:** Click **Turn on** to temporarily open the lens iris for accurate focusing.
- **Step 2 – Adjust focus and zoom:**
 - **Fine-tune focus:** Performs a small-range adjustment for sharper focus.
 - **Full-range scan focus:** Performs a wide-range scan to find the best focus position.

- **Manual focus:** Adjust focus manually using the slider or arrow buttons.
- **Manual zoom:** Adjust zoom manually using the slider or arrow buttons.
- **Step 3 – Enable iris:** Click **Enable** to restore normal iris behavior after adjustment.

Click **Apply** to save changes or **Cancel** to discard them.

Privacy Mask

Privacy Mask allows users to define areas within the camera’s field of view that should be obscured for privacy or compliance purposes. These masked areas appear as solid rectangles and are excluded from both live view and recorded video.

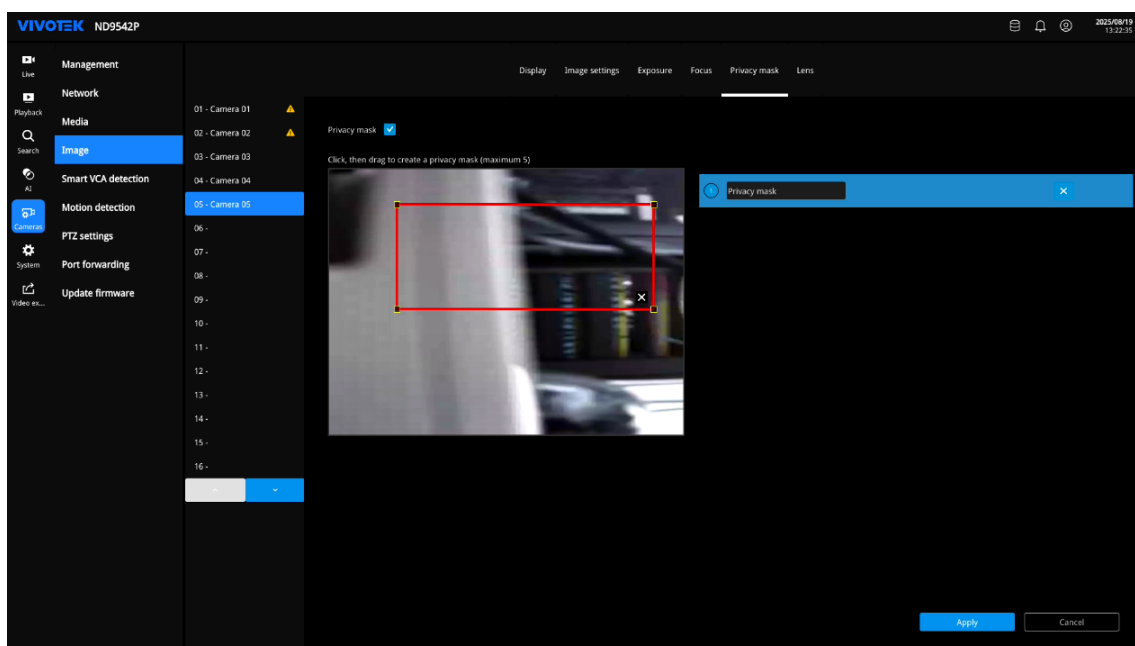

Privacy Mask Configuration

- **Privacy mask toggle:** Enable or disable the privacy mask function.
- **Drawing masks:** Click on the image preview, then drag to create a rectangular privacy mask.
- **Mask limits:** Up to 5 masks can be added per camera channel.
- **Naming:** Each mask is automatically assigned a name (e.g., “Privacy Mask 1”), which can be renamed as needed.
- **Removing masks:** Click the ✕ icon either on the mask rectangle or beside the mask name to remove it. A tooltip labeled “Remove privacy mask” appears when hovering over the icon.

Click **Apply** to save changes or **Cancel** to discard them.

Lens

Lens allows users to select a built-in lens profile that matches the camera’s physical lens. The selected profile ensures accurate image calibration and is required for certain functions such as dewarp or analytics.

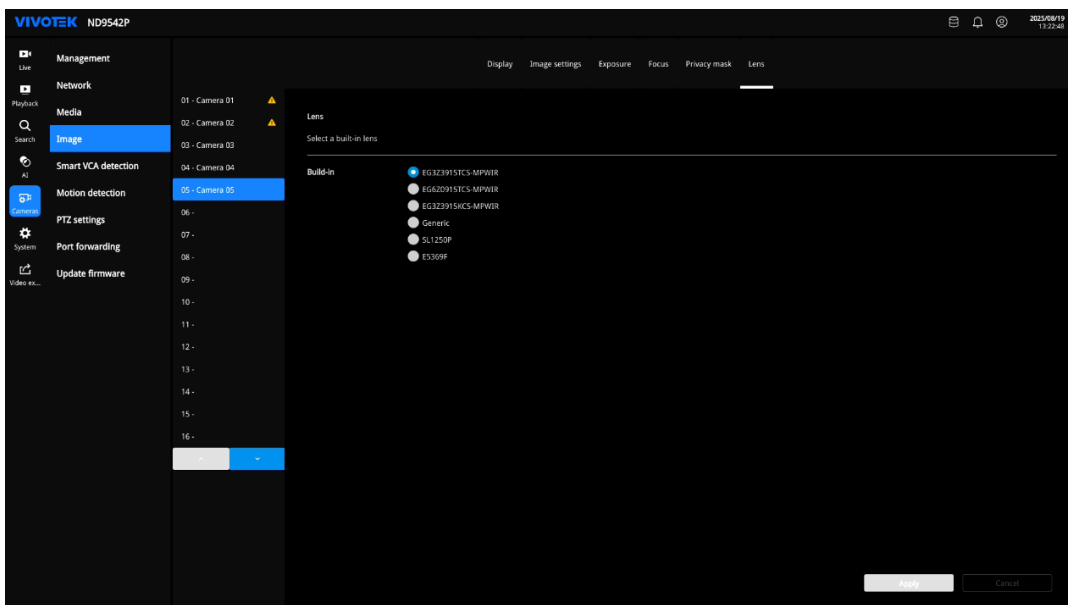

Built-In

Lists preloaded lens models that are compatible with the selected camera. Each option corresponds to a specific lens profile, organized by part number. Select one of the available models, then click **Apply** to activate the configuration.

Generic

Choose **Generic** if the installed lens does not match any of the listed built-in models. This option uses default calibration values and may result in reduced accuracy for advanced features such as VCA and focus optimization.

Smart VCA Detection

The **Smart VCA Detection** page allows users to configure AI-based detection rules for specific cameras. Each rule defines the detection type, target object, detection condition, and schedule.

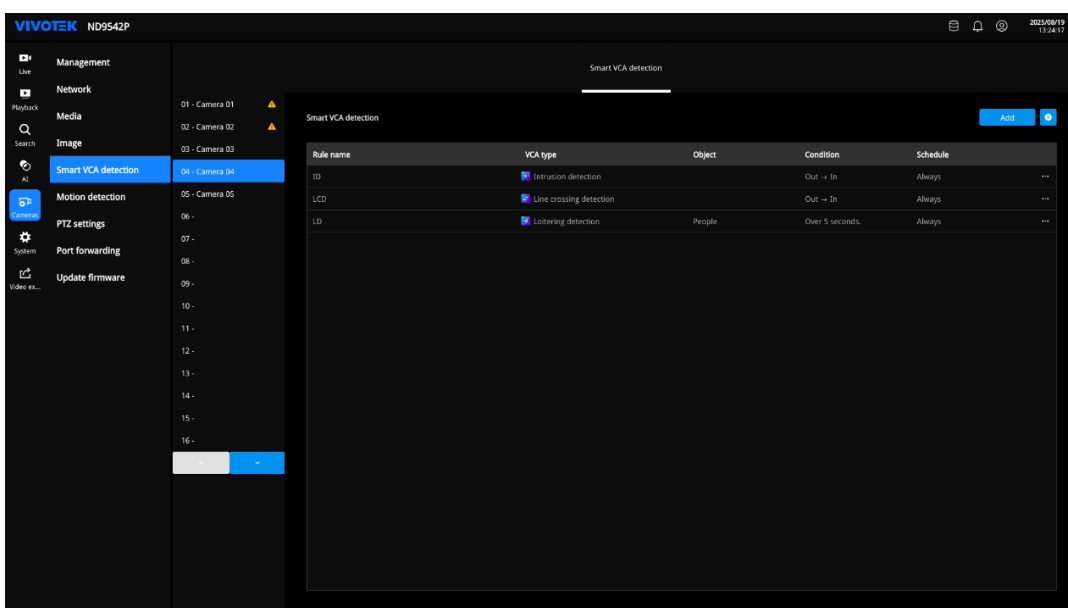

Rule List

The list displays all configured detection rules for the selected camera, including:

- **Rule name:** A user-defined name for each detection rule.
- **VCA type:** The detection type—intrusion, line crossing, or loitering.
- **Object:** The type of objects to detect (e.g., people, vehicles).
- **Condition:** The trigger direction or behavior for detection.
- **Schedule:** When the rule is active.

NOTE

Each camera supports up to 5 VCA rules.

Click **+ Add** to create a new rule.

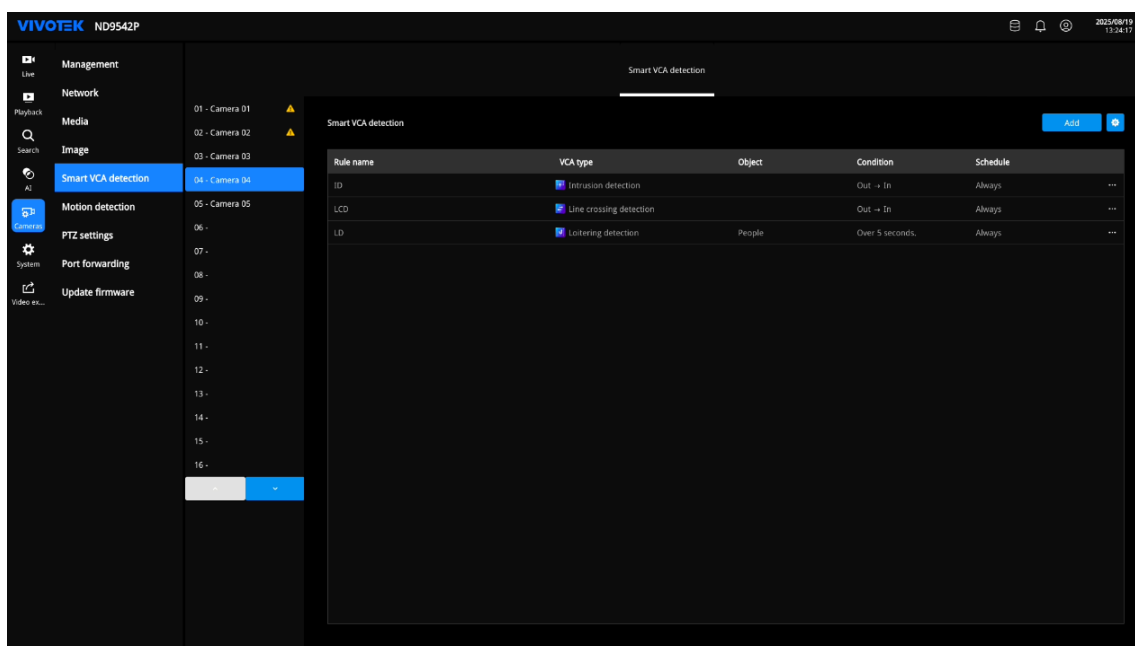

Detection Types

Upon clicking **+ Add**, select one of the following detection types:

- **Intrusion Detection:** Detects objects entering or exiting a defined area.
- **Line Crossing Detection:** Detects objects crossing a user-defined virtual line.
- **Loitering Detection:** Detects when a person remains in an area for a specific period.

All types support object-based filtering:

- All
- People
- 4-wheeled vehicles
- 2-wheeled vehicles

Intrusion Detection

Draw a polygonal detection zone directly on the video panel.

Configure the following in the **Rule settings** panel:

- **Object:** Select object types to detect or choose **All**.
- **Condition:**
 - **Out → In:** Trigger when an object crosses the boundary of the zone. (The system does not differentiate directions.)
 - **In → Out:** Trigger when an object crosses the boundary of the zone. (The system does not differentiate directions.)
 - **All:** Trigger in either direction.

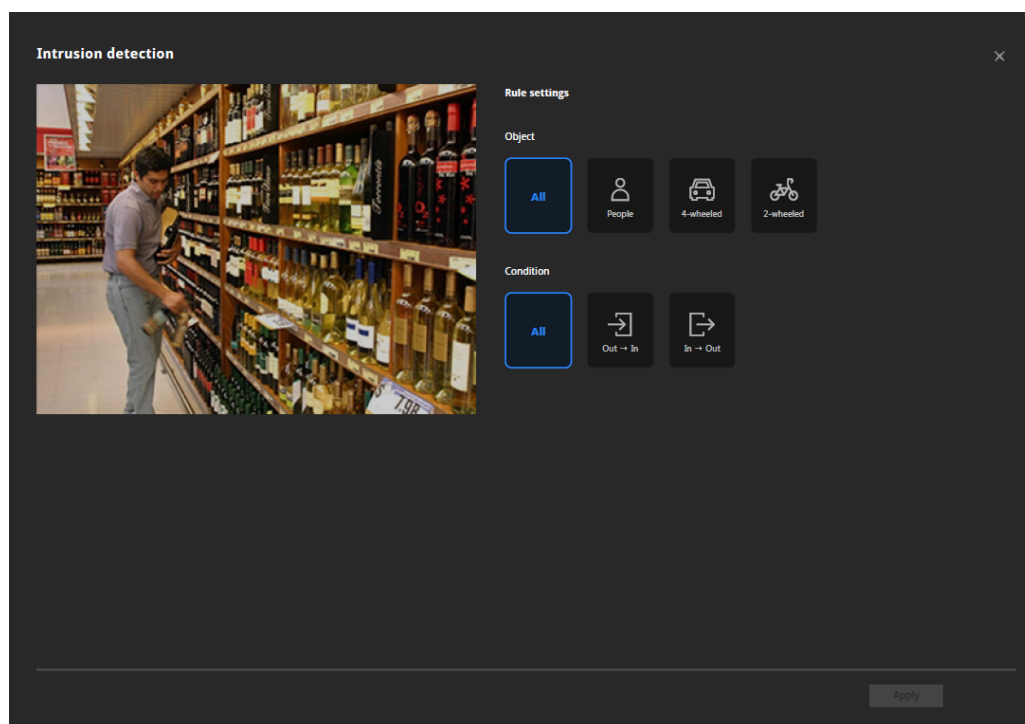

Line Crossing Detection

Draw a virtual line on the video to define the trigger boundary. The direction of travel is indicated by **Out** and **In** labels.

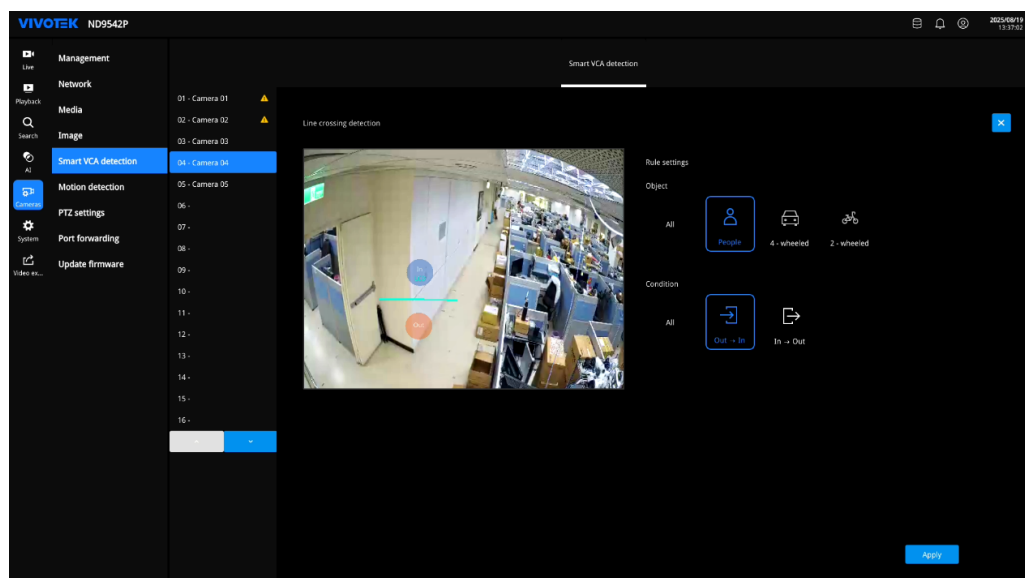

In **Rule settings**, define:

- **Object:** Choose target objects or select **All**.
- **Condition:**
 - **Out → In:** Trigger when the object moves inward.
 - **In → Out:** Trigger when the object moves outward.
 - **All:** Trigger in either direction.

Loitering Detection

Draw an area where the system will detect lingering behavior.

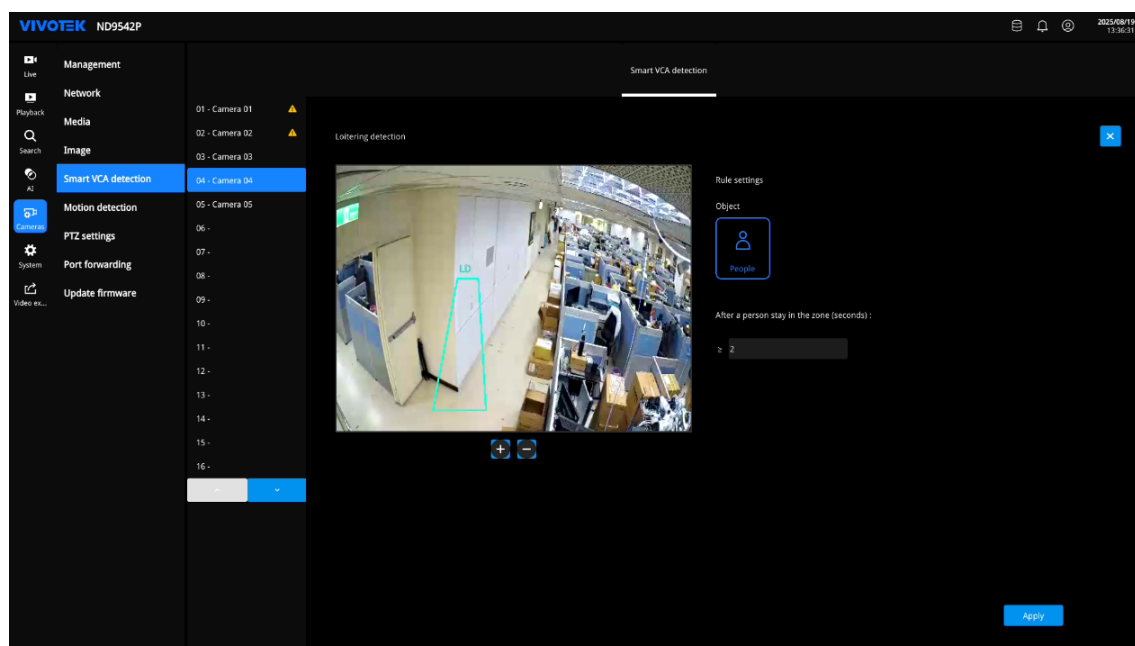

Rule settings include:

- **Object:** Only **People** detection is supported.
- **Condition:** Define the number of seconds a person must remain inside the zone before detection triggers.

Detection Configuration

Click the gear icon (⚙️) to open **Detection Configuration**, where system-wide AI detection behavior is adjusted.

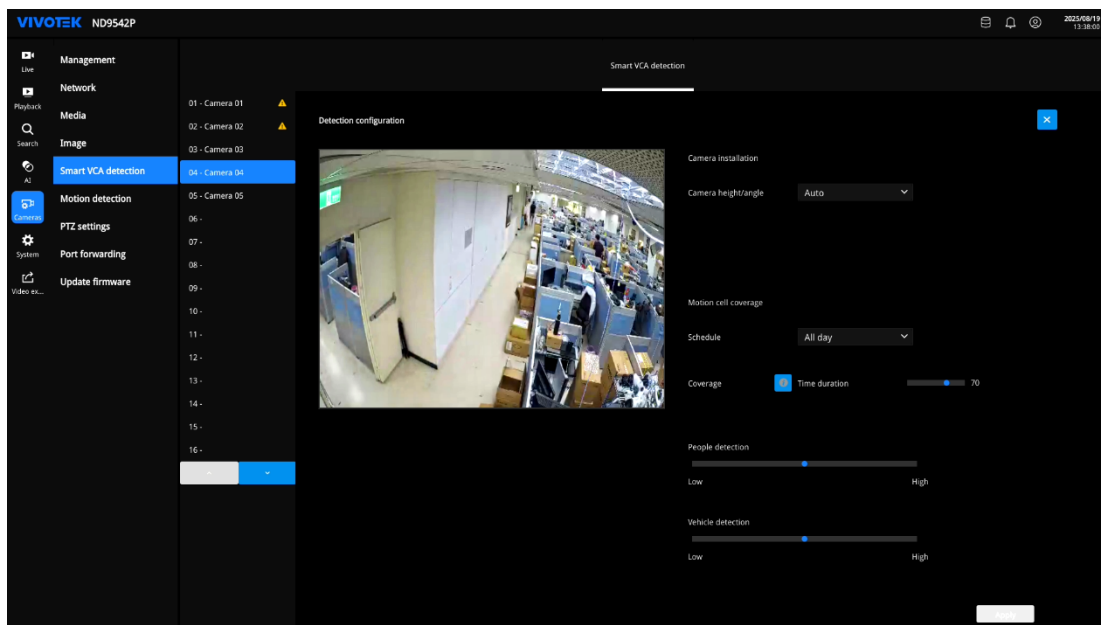

Camera Installation

Specifies how the camera's height and angle are set:

- **Auto:** The system estimates camera parameters automatically.
- **Manual:** Manually enter:
 - **Height (cm)**
 - **Tilt angle**
 - **Roll angle**

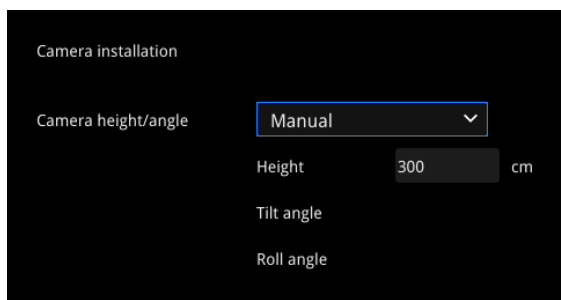

Motion Cell Coverage

Defines how sensitively the system reacts to motion across image cells.

- **Schedule:**
 - **All Day:** Uses one setting for the entire day.
 - **Time Duration:** Apply different settings during a specified time period.
 - **Light Sensor Detection:** Adjusts sensitivity based on day/night lighting.
- **Coverage:** Adjust until only the moving object is covered by motion cells.

Coverage
Adjust motion cell coverage until motion cells are just covered by moving objects.

Detection Sensitivity

Set AI detection sensitivity for different object types:

- **People Detection**
- **Vehicle Detection**

Each slider ranges from **Low** to **High**, balancing detection accuracy and false positives.



Editing or Removing Rules

Click the (More Options) icon next to a rule to access the following options:

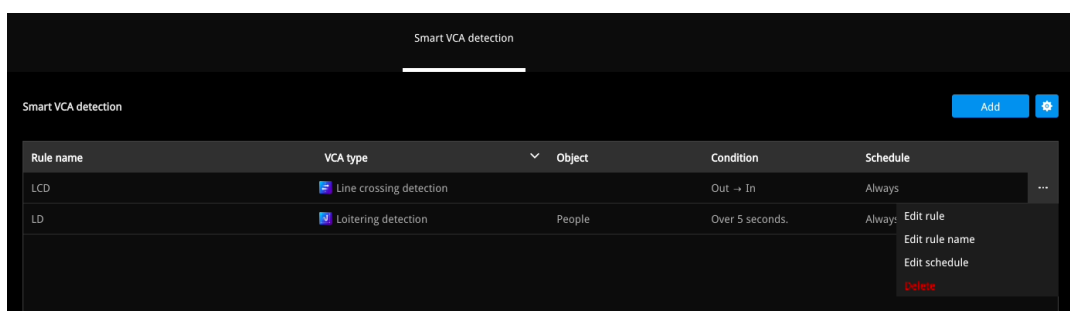

- **Edit rule:** Opens the rule editor with the same interface as when creating a rule.
- **Edit rule name:** Opens a dialog box to modify the name.

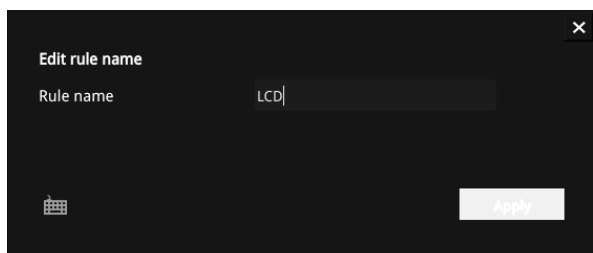

- **Edit schedule:** Allows selecting **Always** or **Custom** schedule. Custom schedules allow configuring a specific time range and selected days.

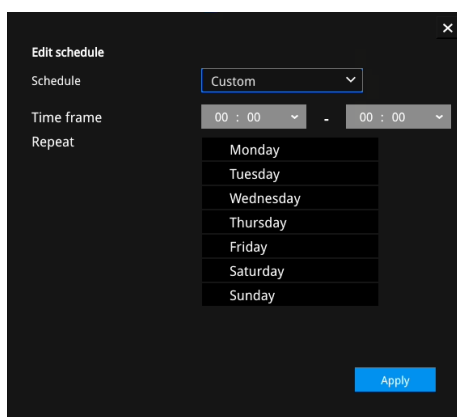

- **Delete:** Removes the rule permanently.

IR Illuminator Bidirectional Detection and Activation

The Motion Detection function enables the NVR to trigger events when motion is detected within a defined area of the camera's field of view. This feature can be used to initiate recording, send notifications, or trigger other actions.

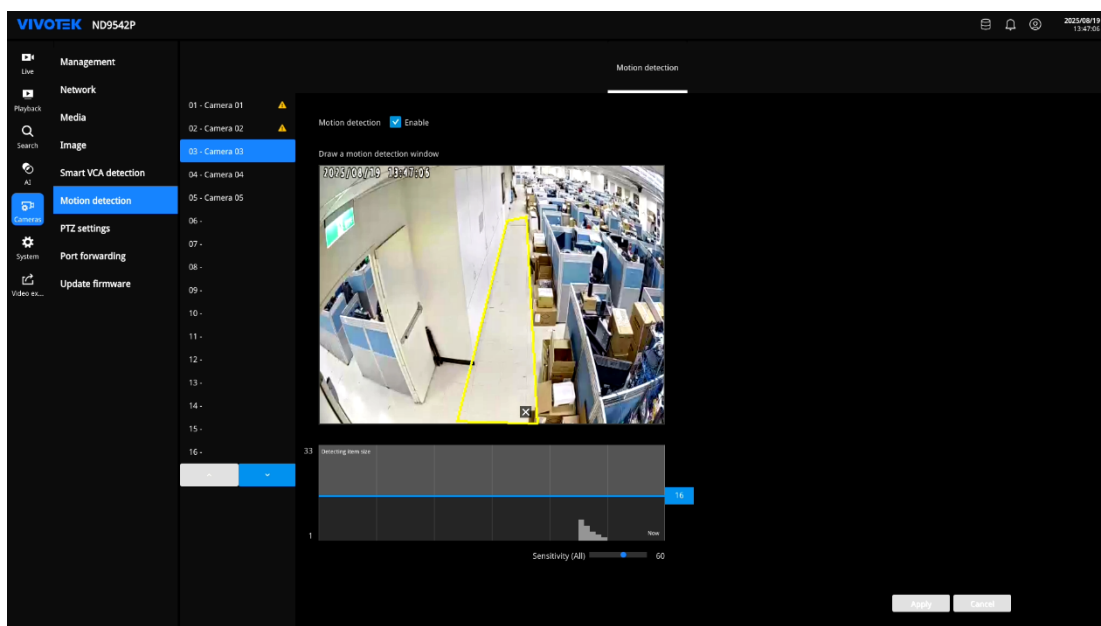

Configuring Motion Detection

Follow the steps below to define motion detection zones and adjust detection parameters:

1. Select a camera from the list.
2. Enable the **Motion detection** toggle at the top of the page.

- In the live video preview, click and drag to draw a polygon-shaped detection window. This window defines the region where motion should be monitored. Multiple points can be adjusted to fit the scene geometry.
- To remove a detection window, click the X icon at its corner.
- Adjust the **Detecting item size** using the vertical slider. This sets the minimum percentage of the detection window that must be occupied by a moving object to trigger an event. The range is from 1 to 33. A lower value allows detection of smaller objects; a higher value filters out smaller movements. For example, a setting of 10 means that motion must cover at least 10% of the defined area to trigger detection.

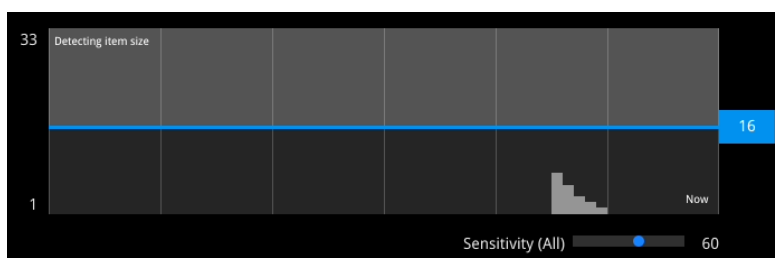

- Adjust the **Sensitivity (All)** using the horizontal slider. Sensitivity determines how readily the system reacts to motion within the detection window. A higher value increases responsiveness to slight movements, while a lower value filters out minor motion. This setting applies uniformly to all defined detection windows.
- Click **Apply** to save the configuration.

Once configured, the motion detection rule can work in conjunction with other system features such as event notifications, recording schedules, or alarm actions.

PTZ Settings

The PTZ (Pan-Tilt-Zoom) Settings page allows configuration of preset positions and patrol sequences for supported PTZ cameras. These settings help automate camera movement to monitor multiple points of interest efficiently.

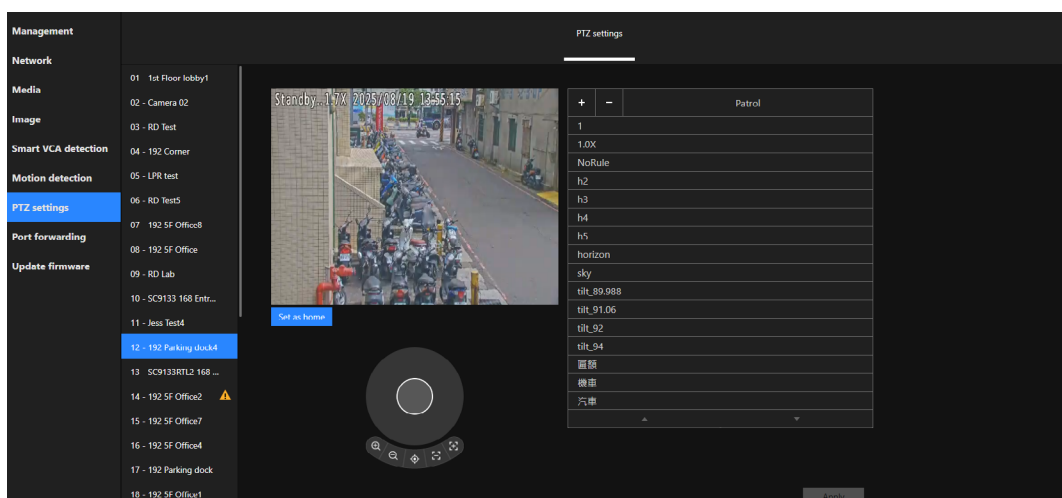

Configuring PTZ Presets

Use the following steps to define and manage preset positions for a PTZ camera:

1. Select a PTZ camera from the list on the left panel.
2. Use the PTZ control pad below the live view to adjust the camera's direction and zoom.
3. Click **Set as home** to define the current field of view as the home position, if needed.
4. Click the + button to add a new preset. Enter a descriptive name and press Enter to save it. The preset will appear in the list.
5. To delete a preset, select it and click the – button.
6. Repeat the process to define multiple presets as needed.
7. Click **Apply** to save all changes.

Configuring Patrol Sequences

Follow these steps to create a patrol route that cycles through multiple preset positions:

1. Click the patrol icon to expand the patrol configuration panel.
2. Set the **Interval** (in seconds) to define how long the camera should stay at each preset.
3. Select a preset from the list to add it to the patrol list.
4. Use the up and down arrows to reorder presets in the patrol sequence.
5. To remove a preset from the patrol list, select it and click the – button.
6. Click **Preview patrol** to simulate the patrol behavior.
7. Click the return icon to go back to the preset configuration list.
8. Click **Apply** to save the patrol configuration.

NOTE

The PTZ panel layout and functions may vary depending on the camera model.

Port Forwarding

The Port Forwarding page allows external users to access cameras behind a NAT router by assigning external ports to each device. This setup enables data from incoming connections to be redirected to the corresponding camera on the private network.

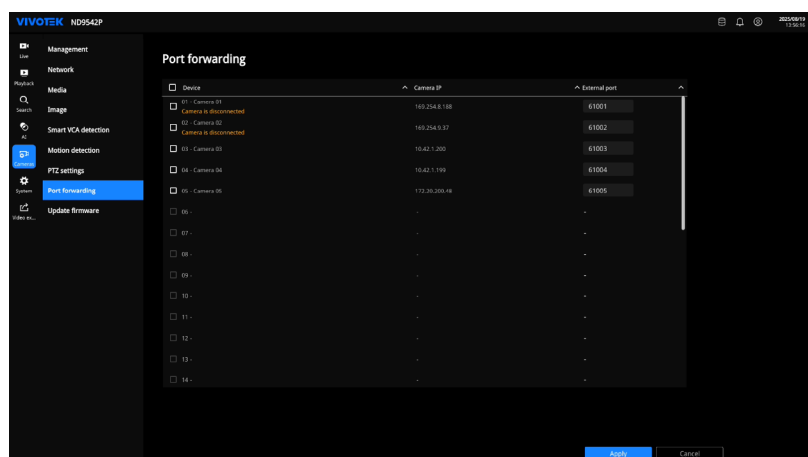

Camera List

Each row in the table corresponds to a camera channel. The system displays the camera's name and its internal IP address. Only connected cameras can be assigned an external port.

External Port

Enter a port number between **61001 and 61128** in the External Port column. This value determines how the camera can be accessed externally. After configuration, requests sent to the NVR's public IP and specified port will be forwarded to the corresponding internal camera.

Example access format:

http://[Public IP]:[External Port]

Router Setup

Port forwarding must also be configured on the network router or firewall to allow external traffic to reach the NVR. Use the same port numbers entered here when setting rules on the router. If port settings are later modified in the **Network** tab, router rules must be updated accordingly.

NOTE

1. This feature is not compatible with legacy cameras that use the RTSP protocol.
2. External ports can only be assigned to cameras that are currently online.
3. Empty rows in the table indicate channels that are either unassigned or disconnected.

Update Firmware

The **Update Firmware** page allows upgrading camera firmware through cloud update or manual file upload. This ensures camera functionality stays up to date and compatible with the NVR.

Status	Firmware file	Camera	IP	Model	Current version
<input checked="" type="checkbox"/>	New firmware available 1.2403.37.01f	01 - Camera name	1.1.1.1	IP9191	1.0.0.1
<input type="checkbox"/>	Select 1 file	02 - Camera name Camera is disconnected	1.1.1.2	IP9191	1.0.0.1
<input type="checkbox"/>	Select 1 file	03 - Camera name Not support 010f camera	1.1.1.3	IP9191	1.0.0.1
<input type="checkbox"/>	Select 1 file	04 -	-	-	-
<input checked="" type="checkbox"/>	Up to date	05 - Camera name	1.1.1.5	IP9191	1.0.0.1
<input checked="" type="checkbox"/>	New firmware available 1.2403.37.01f	06 - Camera name	1.1.1.6	IP9191	1.0.0.1
<input checked="" type="checkbox"/>	New firmware available 1.2403.37.01f	07 - Camera name	1.1.1.7	IP9191	1.0.0.1
<input type="checkbox"/>	Up to date	08 - Camera name	1.1.1.8	IP9191	1.0.0.1
<input checked="" type="checkbox"/>	New firmware available 1.2403.37.01f	09 - Camera name	1.1.1.9	IP9191	1.0.0.1
<input checked="" type="checkbox"/>	New firmware available 1.2403.37.01f	10 - Camera name	1.1.1.10	IP9191	1.0.0.1
<input checked="" type="checkbox"/>	New firmware available 1.2403.37.01f	11 - Camera name	1.1.1.11	IP9191	1.0.0.1
<input type="checkbox"/>	Up to date	12 - Camera name	1.1.1.12	IP9191	1.0.0.1
<input checked="" type="checkbox"/>	Up to date	13 - Camera name	1.1.1.13	IP9191	1.0.0.1

Update via Cloud

Cloud update is supported on both the local console and the web interface. To use this feature, the NVR must be connected to VORTEX and bound to an organization.

To perform cloud update:

1. When the NVR detects that newer firmware versions are available from the cloud, a notification appears at the top of the page. Click **Check** to check whether newer cloud firmware is available for the connected cameras.

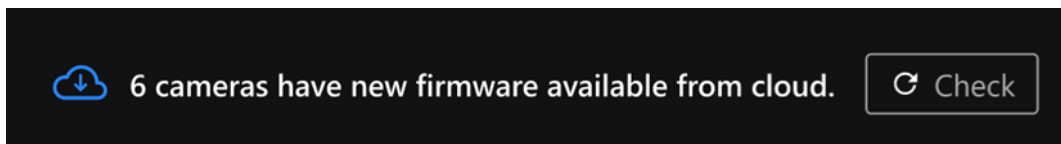

2. A cloud icon appears in the **Status** column when a newer cloud firmware version is available for that camera.



3. Cameras with cloud firmware available are selected automatically. If a different update source is preferred, the firmware file can be selected manually using the drop-down menu in the Firmware file column.
4. Cameras can be updated using cloud firmware, manually uploaded firmware files, or both. After selecting the desired cameras, clicking **Update** initiates all selected updates simultaneously, regardless of whether the source is a cloud file or a manual file.

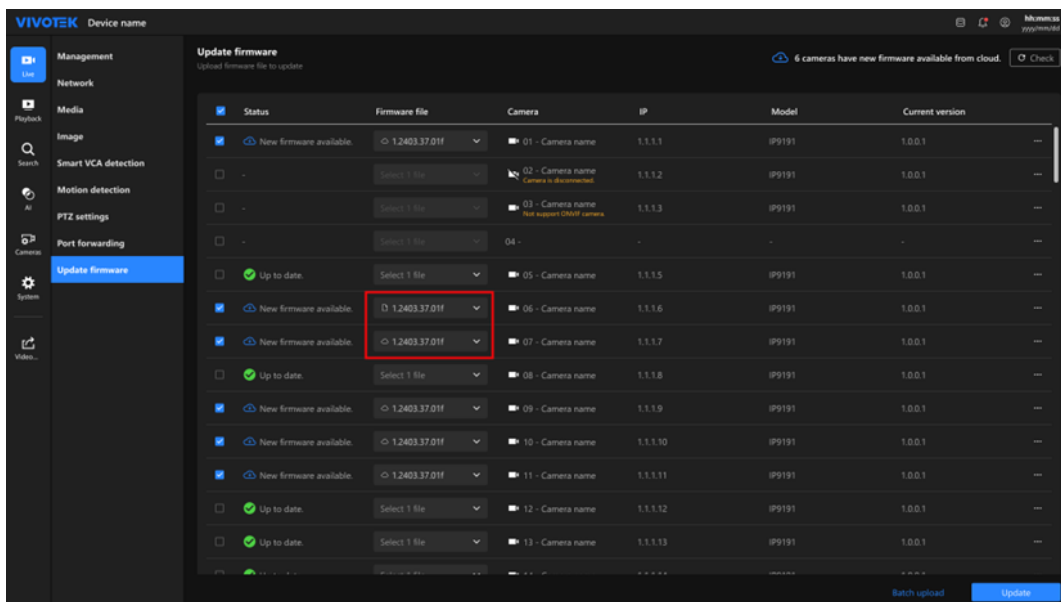

5. Once completed, the system displays the update result in the corresponding field, such as "Cloud update completed."

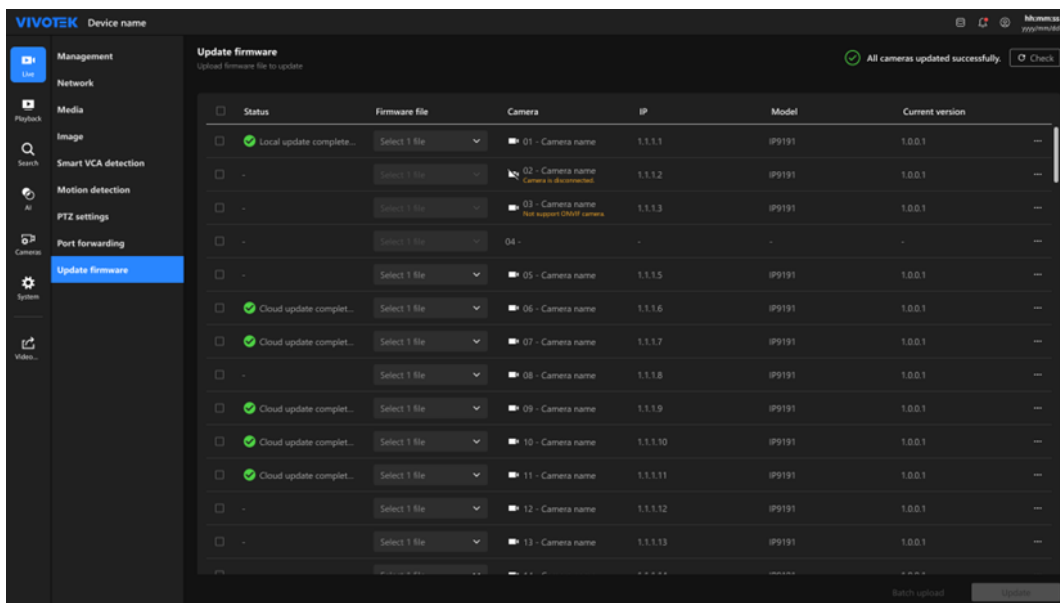

Manual Update

Manual update allows assigning a firmware file instead of using cloud update.

Update from the Local Console

1. Insert a USB flash drive containing the firmware file into a USB port on the NVR.
2. Navigate to the **Update Firmware** page under the **Cameras** module.
3. Open the **Firmware file** drop-down menu for the target camera.
4. Select **Upload file**.
5. Choose a firmware folder from the USB and select the firmware file.

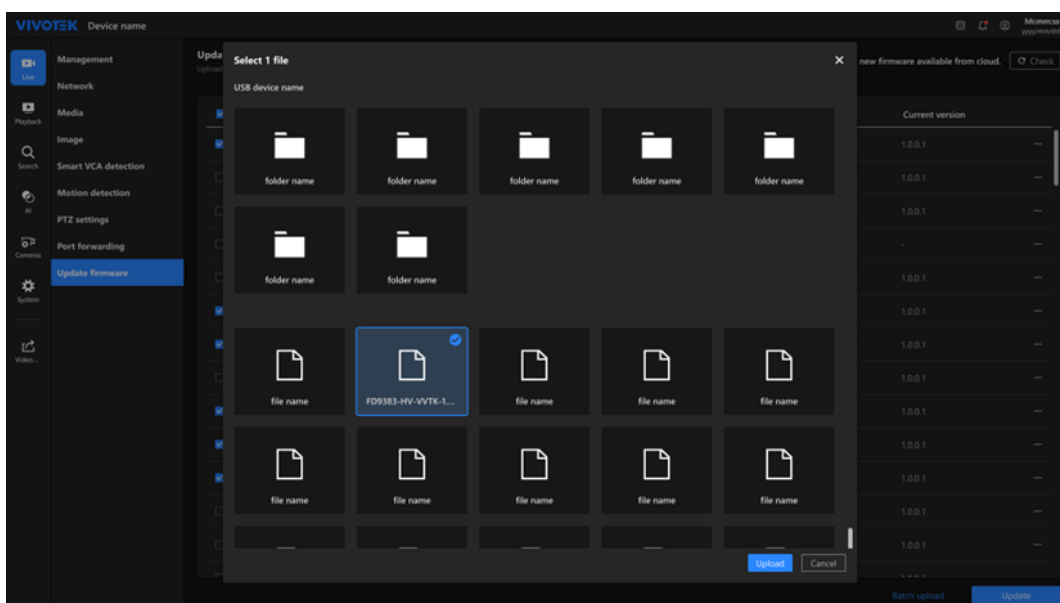

6. The selection switches automatically to the uploaded file.
7. Click **Update** to begin the update process.
8. Once complete, the system displays the update result in the corresponding field.

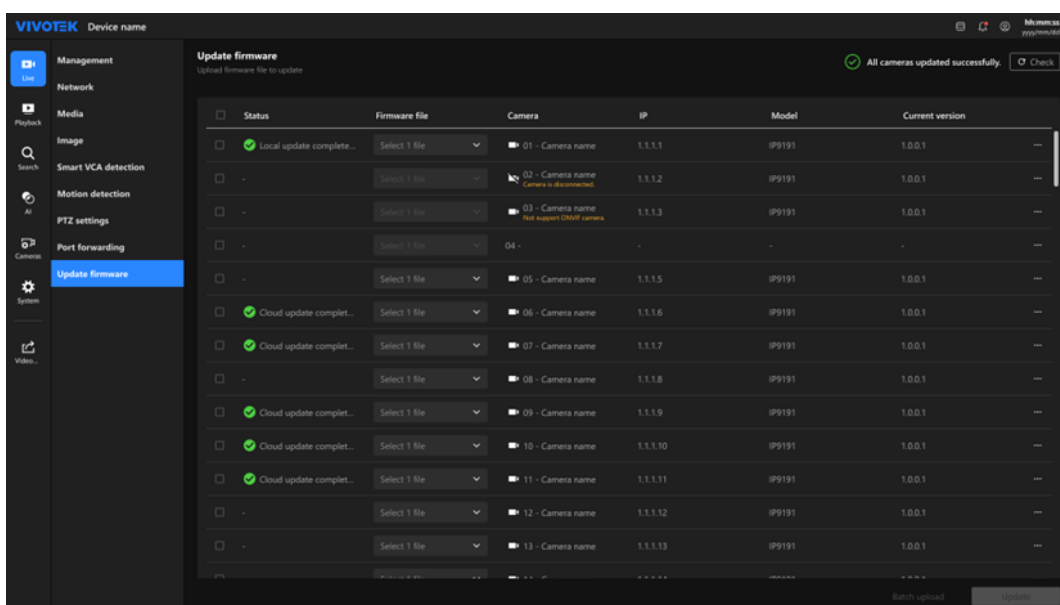
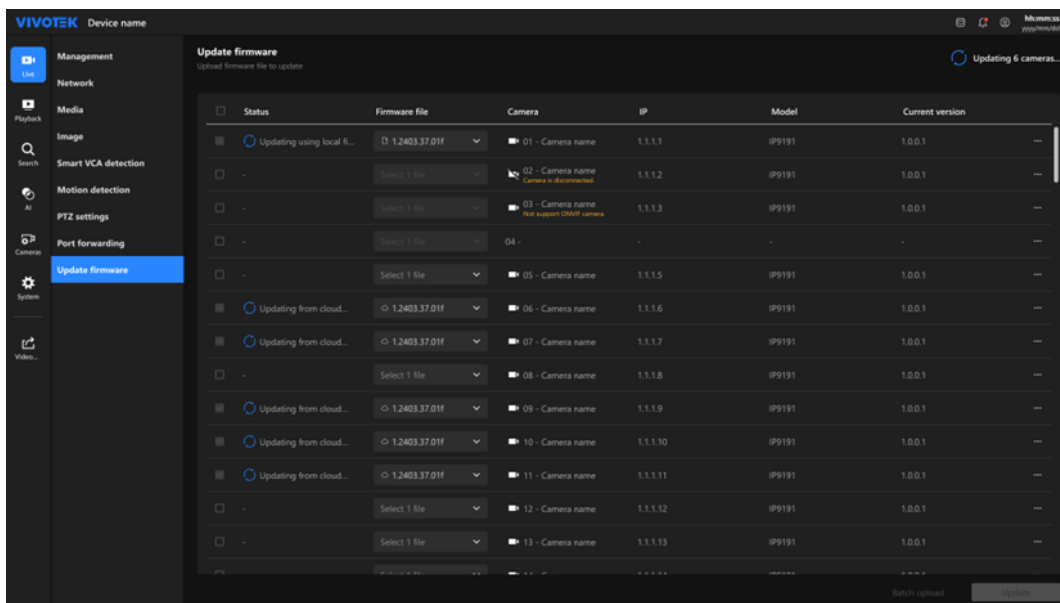

Update from a Web Browser

1. Log in to the NVR using a supported browser.
2. Navigate to the **Update Firmware** page under the **Cameras** module.
3. Open the **Firmware file** drop-down menu for the target camera.
4. Select **Upload file** to choose the firmware file on the PC.
5. The selection switches automatically to the uploaded file.
6. Click **Update** to begin the update process.
7. Once complete, the system will display the update result in the corresponding field. (See the illustration in the previous section.)

Batch Upload

Batch upload allows multiple firmware files to be uploaded at once. Uploading files does not perform the firmware update automatically. Users must still select the desired cameras and click **Update** to begin the update process.

To batch upload firmware files & update firmware:

1. Click **Batch Upload** in the lower-right corner.

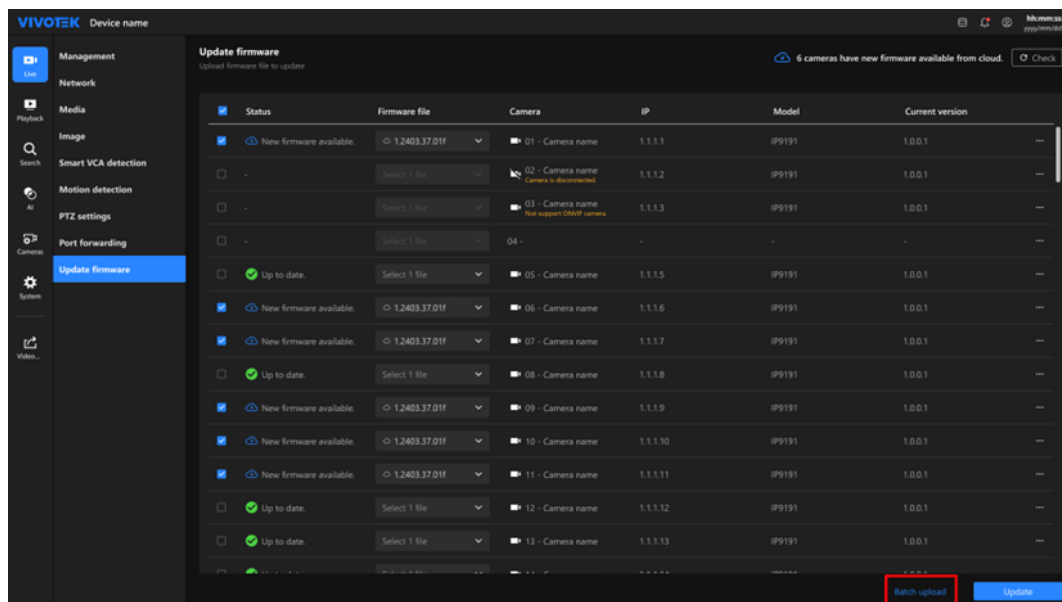

2. Select a firmware source:
 - **Local console:** Choose a folder on the USB device connected to the NVR.
 - **Web interface:** Choose one or more firmware files stored on the computer.
3. Click **Upload** to import the selected files.
4. After uploading, the dropdown menu selection switches automatically to the uploaded file.
5. Cameras applied with the newly updated firmware are selected automatically.
6. Click **Update** to begin the firmware upgrade.

Note

Up to 8 cameras can be updated at the same time. Additional cameras continue automatically after the previous group completes.

Apply to Matching Cameras

This function allows applying the uploaded firmware file to other cameras of the same model.

1. Click the **More (...)** icon in the rightmost column and select "Apply upload file to matching cameras."

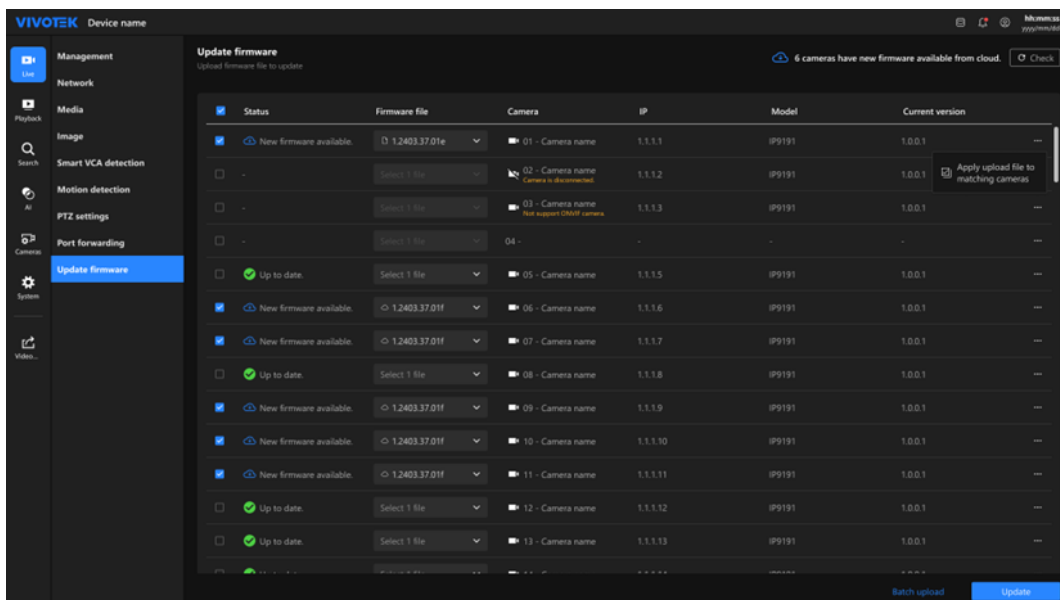

2. The system automatically assigns the same firmware file to all matching cameras and selects them.

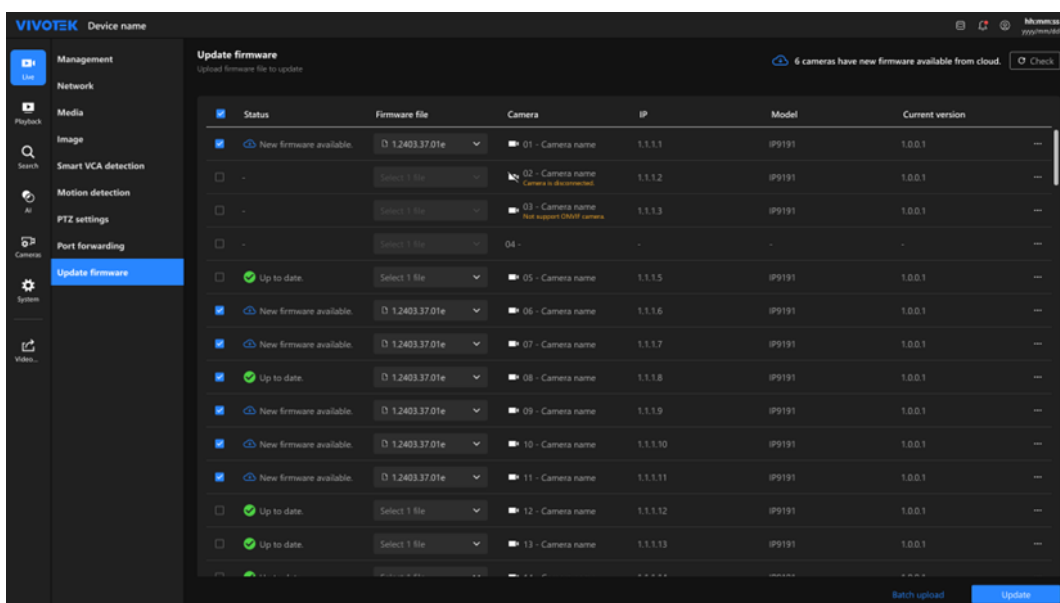

3. Click **Update** to begin the update process.

The **System** module provides access to essential settings that define how the NVR operates. Within this module, you can manage system information, display options, storage, recording, alarms, network settings, services, PoE, user accounts, and perform maintenance tasks. Each page under this module focuses on a specific area to ensure stable system operation and simplify ongoing administration.

Device

The **Device** page displays system information and provides options for language and time configuration.

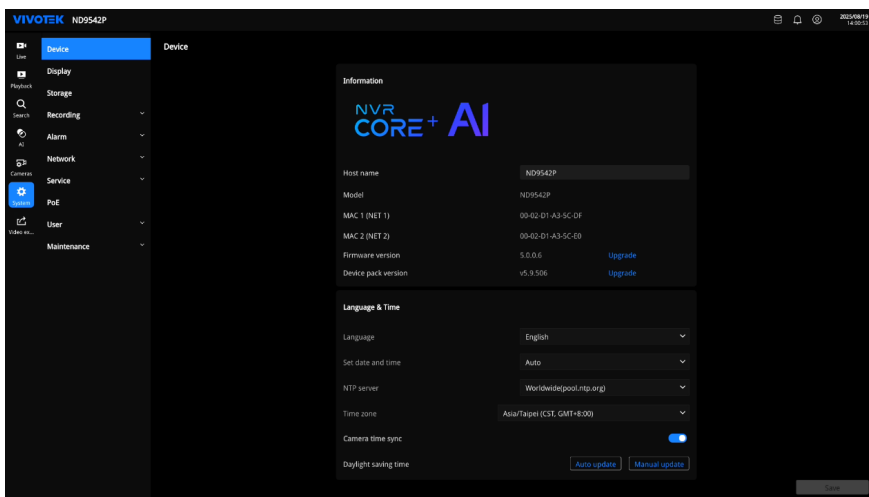

Information

The **Information** card presents basic device details such as model, MAC address, and firmware version, supporting identification and system maintenance.

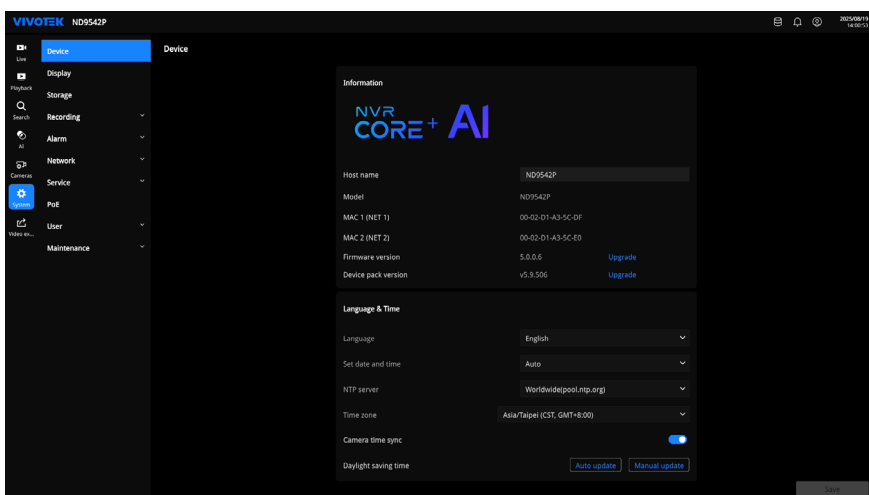

Host Name

Displays the NVR's assigned name, which can be edited to make identification easier in multi-device environments.

Model

Shows the NVR model number for identifying the specific device during maintenance or troubleshooting.

MAC 1 (NET 1) / MAC 2 (NET 2)

Lists the MAC addresses of the two network interfaces, which are useful for network setup and device identification.

Firmware Version

Displays the currently installed firmware version and allows upgrading when a newer version is available.

Device Pack Version

Displays the currently installed device pack version and allows upgrading to support additional camera models.

Language & Time

The **Language & Time** card defines the interface language and ensure that the system clock is accurate. Correct time configuration is essential for event logs, recordings, and synchronization with connected cameras.

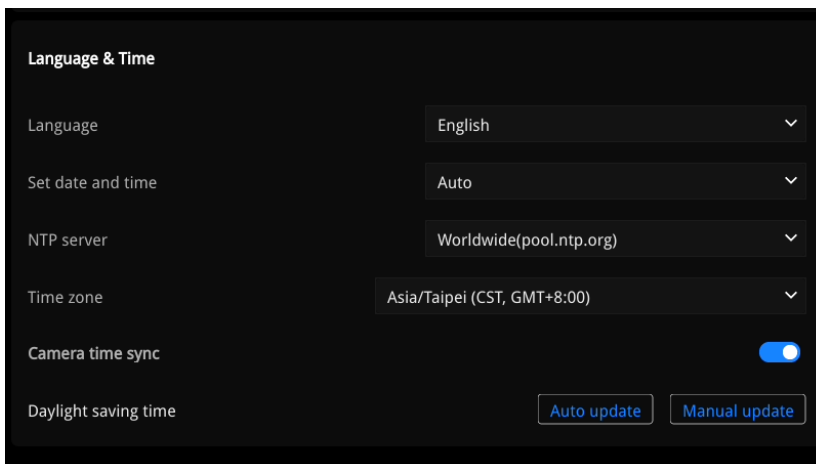
**Language**

Selects the display language for the user interface. Supported 15 languages, including English (default), Deutsch, Español, Français, Italiano, 日本語, Português, 简体中文, 繁體中文, Čeština, Русский, 한국어, Polski, العربية, and תיבוע.

Set Date and Time

Configures the system clock either automatically through an NTP server or manually.

- **Auto**

When "Auto" is selected, the NVR synchronizes the date and time automatically with the specified **NTP server**. The NTP Server field appears for specifying the server to be used for synchronization.

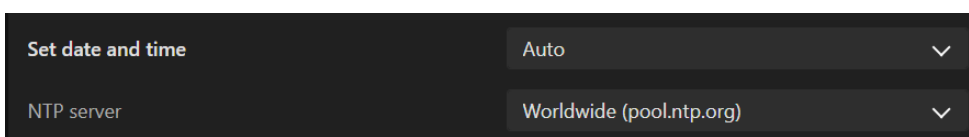

- **Manual**

When “Manual” is selected, the NTP Server field is replaced by **Date** and **Time** fields. The date is set using a date picker, and the time is set using a time picker.

Time Zone

Specifies the time zone for the system clock. Enter text in the field to filter the available options in the drop-down list. Matching results appear automatically as text is entered. Select the desired time zone from the list to apply the setting.

Camera Time Sync

When enabled, this option synchronizes the time on all connected cameras with the NVR. Toggling the switch on updates camera time to match the NVR clock; toggling it off stops automatic synchronization.

Daylight Saving Time

Enables or disables daylight saving time adjustment. When daylight saving time settings are modified, the NVR will reboot to apply the changes.

Two update options are available:

- **Auto Update**

Retrieves the latest DST data from the NTP server and applies it automatically. The NVR reboots after the update is applied.

- **Manual Update**

Allows updating DST data by downloading the latest file from <https://www.iana.org/time-zones> and uploading it to the NVR. The NVR reboots after the update is applied.

Display

The **Display** page configures how video output is shown on monitors connected to the NVR. These settings apply only to the local console and do not affect the web console.

Multiple Display

The Multiple Display card defines how video output behaves when more than one monitor is connected. It allows selecting between duplicating the same view on all monitors or extending the desktop so that different content is displayed on each screen. This card also provides options for resolution, rotation interval, preloading, and specifying the monitor used for full screen alarm display.

Multiple Display

Specifies how the system uses multiple monitors when more than one display is connected.

- **Duplicate These Display (Default)**

Shows the same content on all connected monitors. Resolution, rotation interval, and preload settings are configured once and applied to every monitor.

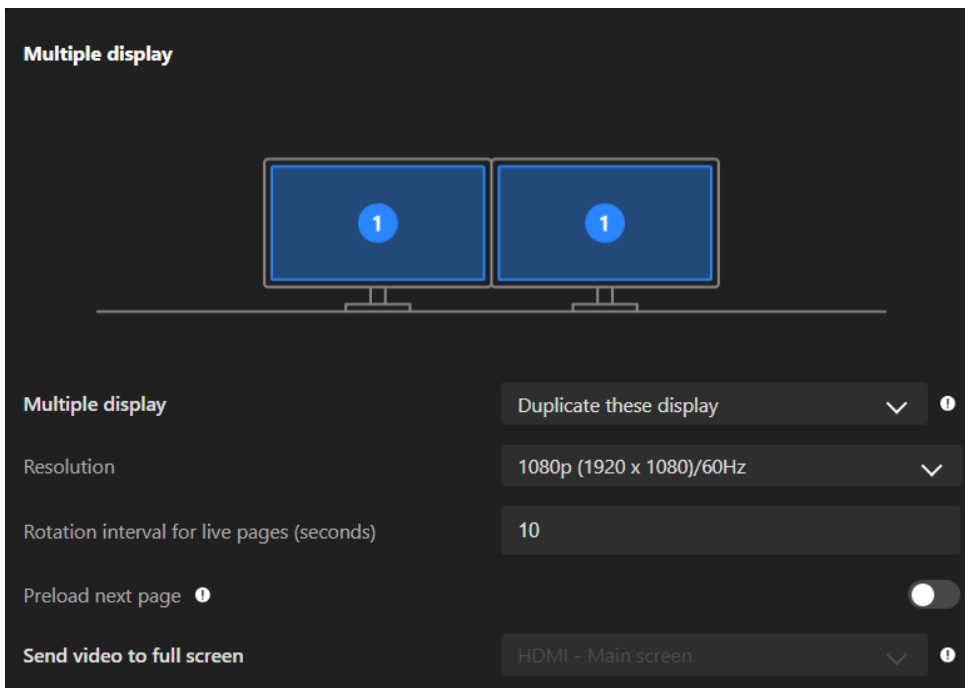

- **Extend These Display**

Uses an extended desktop so that different content can be displayed on each monitor. When this mode is selected, separate configuration panels appear for each connected output (for example, HDMI – Main screen and VGA – Sub screen). Settings such as resolution, rotation interval, and preload can be configured individually for each output.

When Extended Display is enabled on ND9542P models, Deep Search support is limited to 20 channels. In addition, the Sub screen does not support 4x4 and 1M+12 layouts. To manage which channels use Deep Search, go to the Recording settings.

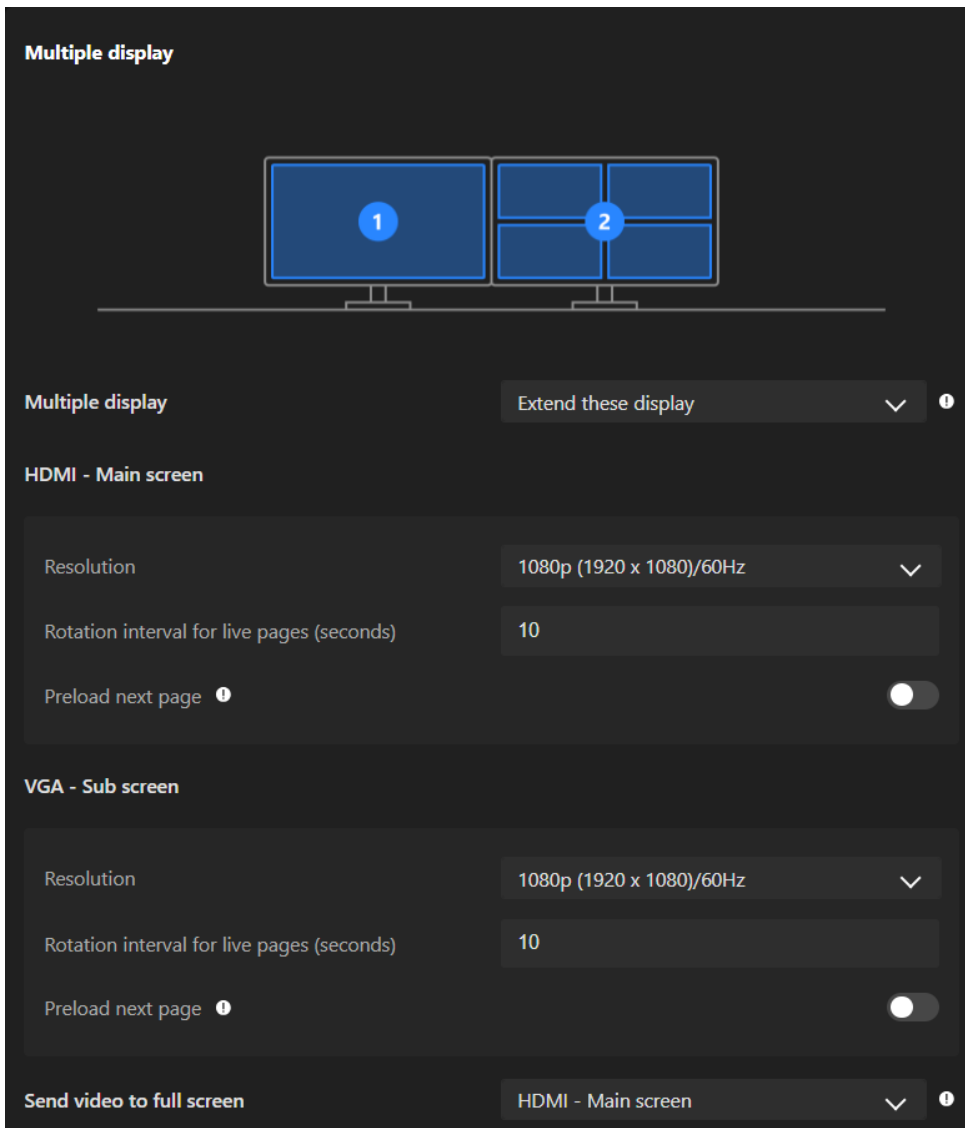

Resolution

Sets the output resolution and refresh rate for the selected display. Available options depend on the connected monitor's supported resolutions.

- **720p (1280 × 720) / 60 Hz**

Low resolution with 60 Hz refresh rate, suitable for smaller or lower-performance monitors.

- **1080p (1920 × 1080) / 60 Hz (Default)**

Full HD resolution at 60 Hz refresh rate. This is the default setting and provides a balance between performance and image clarity.

- **4K (3840 × 2160) / 30 Hz**

Ultra HD resolution at 30 Hz refresh rate, recommended for 4K monitors when high detail is required.

Rotation Interval for Live Pages (Seconds)

Defines the interval, in seconds, for rotating through live view pages when multiple live pages are enabled on the selected display.

Preload Next Page

When enabled, the next live view page is preloaded in advance to make transitions smoother. When disabled, the page loads only when it is displayed. Enabling this option improves switching speed but may use more system resources.

Send Video to Full Screen

Selects which display will switch to full-screen video output when triggered (for example, HDMI – Main screen or VGA – Sub screen). When an alarm action is configured to “Send video to full screen,” this setting specifies which monitor (for example, HDMI – Main screen or VGA – Sub screen) will display the full-screen video.

Storage

The **Storage** page displays the available storage space on the NVR and provides tools to manage volumes and check disk health. These settings only affect the local console and do not change existing recordings.

NVR Storage

The top section shows the total storage capacity of the NVR and the amount of space currently used. The bar is color-coded: blue indicates used space and gray indicates available space. An estimated number of recording days is also shown based on current storage usage and recording settings.

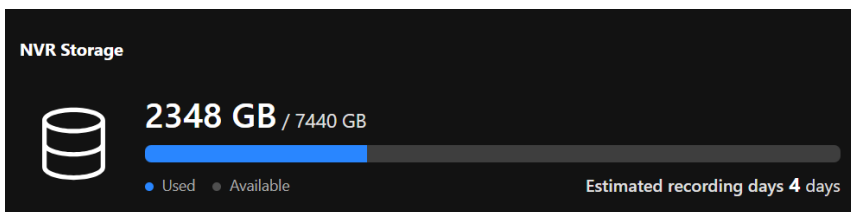

If the NVR cannot calculate an estimate because no cameras have been added, the value is shown as “–” and an information icon appears. Hovering over the icon displays a tooltip with the title “Unable to estimate recording days” and the description “No camera added.”

Volume

Each volume represents a storage pool that can contain one or more disks.

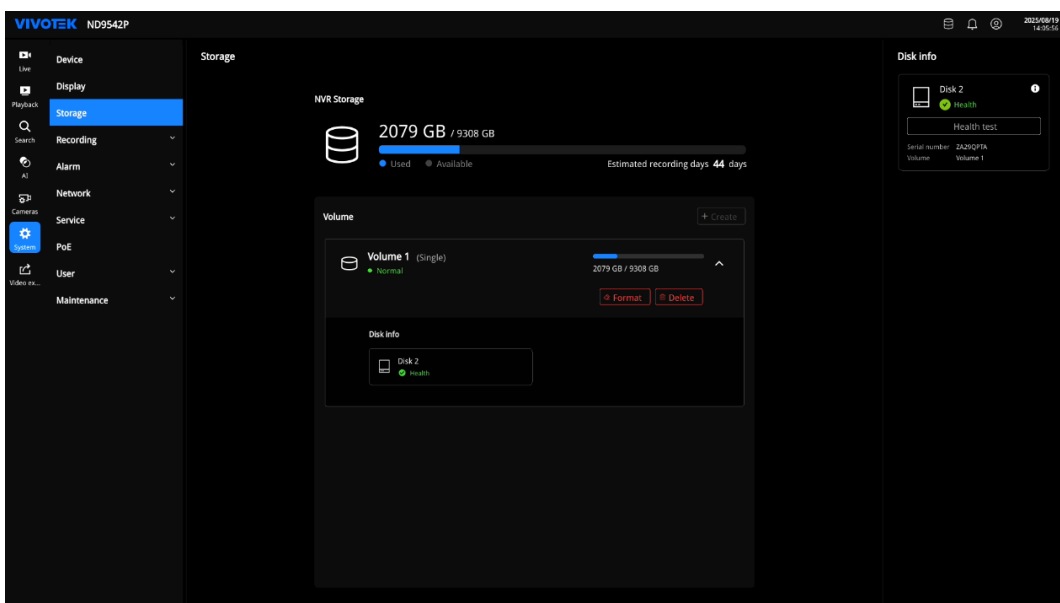

The collapsed view shows the volume name, type (for example, Single), status, and a capacity bar with used and total size. Expanding a volume reveals additional options and information:

- **Format** – Erases all data on the selected volume and reinitializes it for recording.
- **Delete** – Removes the selected volume configuration.
- **Disk Info** – Lists the physical disks included in the volume, along with their health status.

Click the “+ Create” button to add a new volume. If no additional disks are available, the button is disabled.

IMPORTANT

1. Deleting a volume permanently removes all recordings stored in it. Be sure to back up your data before proceeding.
2. The lift on the 16TB volume limitation also applies to USB3.0 external storage.

Rebuild Volume

When a volume becomes degraded due to disk errors or failures, the system provides a **Rebuild** option to restore the volume and recover data redundancy.

The **Rebuild** button appears next to the affected volume when restoration is possible.

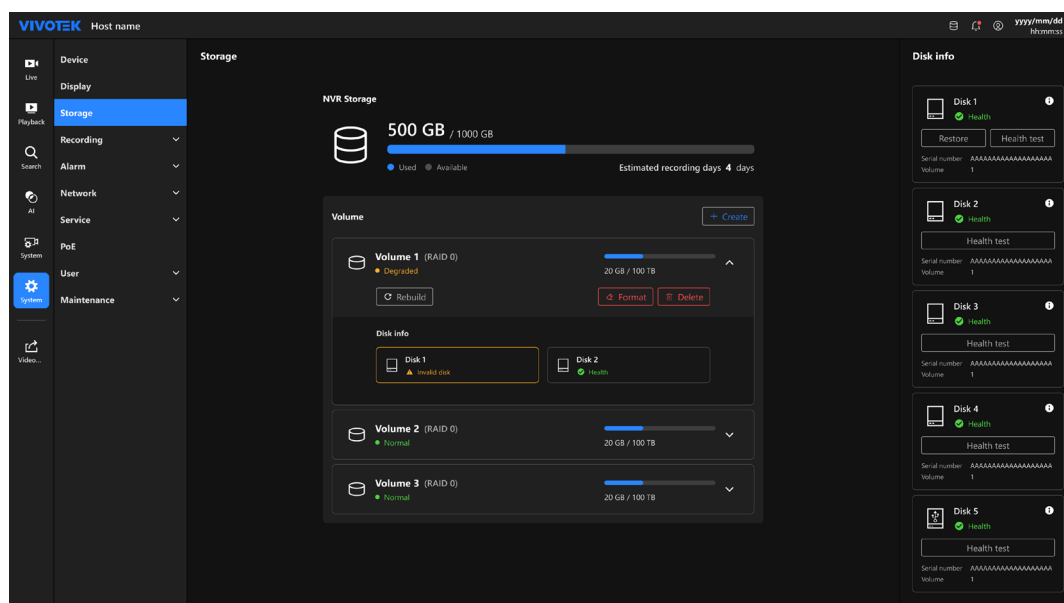

Clicking **Rebuild** starts the rebuilding process. During rebuilding, the system displays the status and progress percentage. The process can be stopped at any time by clicking **Stop**. Stopping the process cancels the rebuilding action. While a volume is rebuilding, the **Format** and **Delete** options are disabled for that volume.

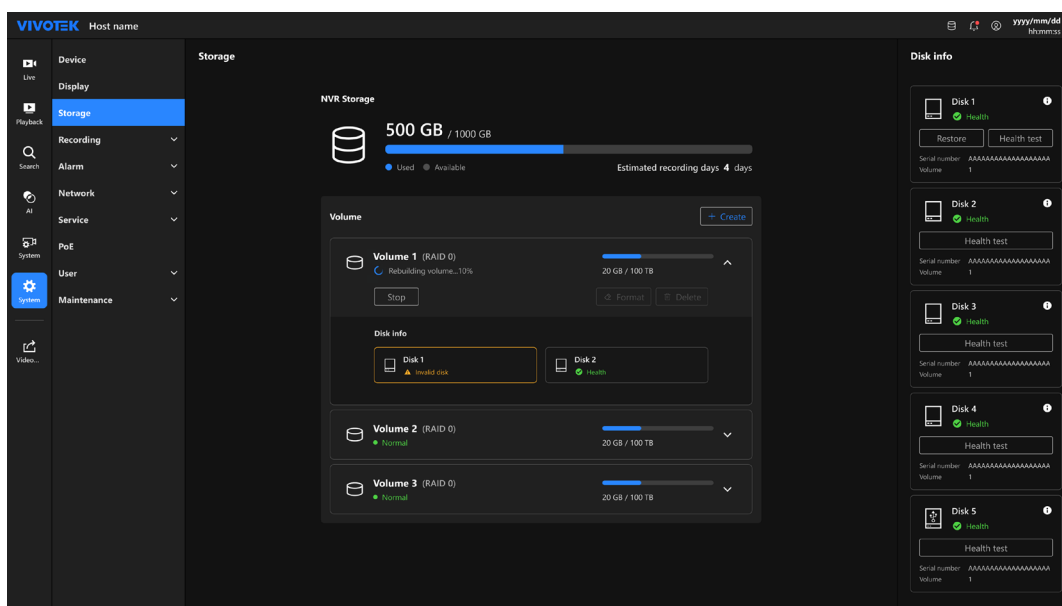

Disk Info

On the right side of the page, a panel shows the status of all disks used in this NVR. For each disk, the panel displays:

- Disk name and serial number
- Current health status
- The volume to which the disk belongs
- A **Health test** button for running diagnostic checks.

Health Test

Clicking **Health test** opens a dialog where you can choose from three types of tests:

- **Bad block** – Scans the disk surface for bad sectors.
- **Fast S.M.A.R.T.** – Performs a quick S.M.A.R.T. diagnostic.
- **S.M.A.R.T.** – Performs a full S.M.A.R.T. diagnostic.

Disk Details

Clicking a disk in the panel opens a detailed view with two sections:

- **Disk info** – Shows the model family, model name, and volume assignment.
- **S.M.A.R.T.** – Displays attributes such as Raw Read Error Rate and other health indicators. For each attribute, the current value, the worst recorded value, and the threshold are shown. The top of this section also shows the **Last check**, which records the most recent health test type, date and time, and result (for example: Fast S.M.A.R.T., 2025/01/15 14:38:45, Passed).

Recording

This module describes the settings related to video recording on the NVR. The Recording menu provides two sub pages:

- **Recording Option** – Configure how each camera records, including recording mode, retention period, stream type, and Deep Search metadata.

- **Backup** – Create backups of recorded video to external storage for archiving or investigation.

These settings allow the system to optimize storage capacity while ensuring that critical video footage is recorded and retained according to operational requirements.

Recording Option

The **Recording Option** page provides a centralized interface to manage recording settings for each camera connected to the NVR. From this page, users can adjust the recording mode, retention period, stream type, seamless recording, and Deep Search options.

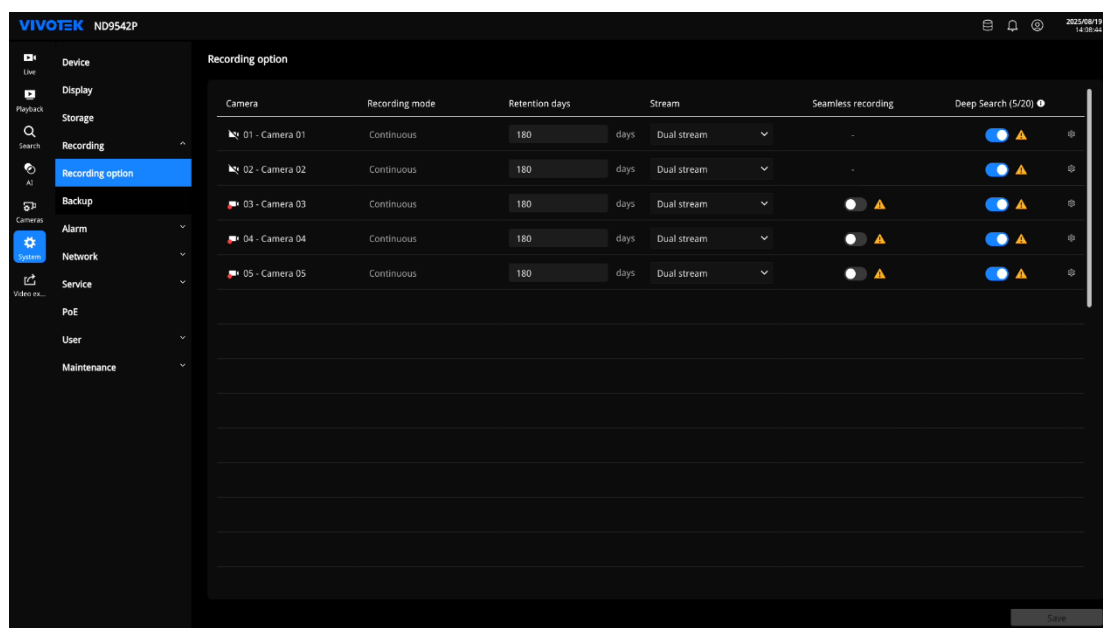

Camera List

All cameras added to the system are displayed in a list. The following settings can be configured for each camera.

Recording Mode

The recording mode defines how the NVR stores video from each camera. Four modes are available:

- **No recording** – No recordings are scheduled.
- **Continuous** – The schedule contains only continuous recording periods.
- **Event** – The schedule contains only event-triggered recording periods.
- **Schedule** – The schedule includes both continuous recording periods and event-triggered periods, depending on the configured time slots.

Retention Days

Specifies the number of days that recorded video is stored on the NVR. Older footage is automatically overwritten when the defined retention period is reached.

Stream

Determines which video stream is used:

- **Main** – Records using the main stream.
- **Dual stream** – Records both main and sub streams.

Seamless Recording

For cameras with SD card support, enabling seamless recording allows the NVR to retrieve video stored on the camera during a temporary network or power interruption.

NOTE

1. Recording data will not be backed up if the camera is connected through the NVR's PoE port during a power interruption on the NVR.
2. Ensure that each camera is equipped with a compatible SD card to enable seamless recording. RTSP and ONVIF cameras do not support seamless recording recovery.
3. Do not update the camera clock while seamless recording recovery is in progress, as this may cause repeated playback or broken video files.
4. If a video file is being recorded when the network connection or power is interrupted, that file will be corrupted and cannot be recovered by seamless recording.
5. For more details on these configurable options, refer to the user manuals provided with your network cameras.

Deep Search

Enables or disables Deep Search for cameras that support this function. When enabled, the NVR collects object attributes such as people and vehicle information and stores the metadata for AI-powered search. The system automatically recycles old metadata to maintain storage efficiency.

For ND9542P models, when Extended Display mode is enabled, Deep Search can be applied to a maximum of 20 channels. Once the limit is reached, additional channels will be shown as Off and cannot be enabled.

Deep Search is not available for cameras that do not support this function, including RTSP and ONVIF cameras.

Please ensure compliance with privacy regulations and obtain necessary consent when using this function.

Advanced Configuration

Click the settings icon next to a camera, then select **More settings** to open the **Recording options** window.

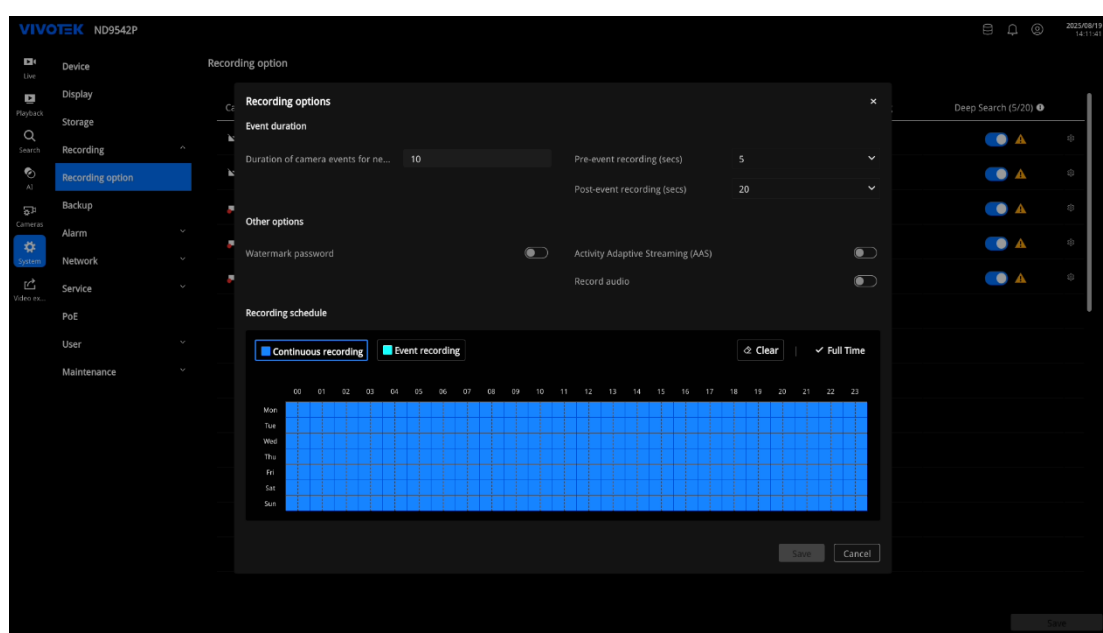

In this window, advanced options are organized into three sections:

Event Duration

Configure how the system handles triggered recordings:

- **Duration of camera events for next trigger:** Defines the interval (in seconds) before a new event from the same source will be recognized.
- **Pre-event recording:** Specifies how many seconds of video are recorded before the event occurs.
- **Post-event recording:** Specifies how many seconds of video continue to be recorded after the event ends.

Other Options

Additional options for recording behavior:

- **Watermark password:** Adds a password to exported video clips. The password can later be used to verify that the exported video has not been altered.
- **Activity Adaptive Streaming (AAS):** When enabled, automatically adjusts the video bitrate depending on the amount of motion in the scene, reducing storage usage during periods of low activity.
- **Record audio:** Enables or disables audio recording for the selected camera.

Recording Schedule

Defines when the camera records continuously and when it records only on events.

- Use the **Continuous recording** or **Event recording** buttons to select a recording mode.
- Drag the mouse over the time grid to configure recording periods. Each cell represents 30 minutes.
- Use **Clear** to remove existing time blocks or **Full time** to quickly apply recording to the entire day.
- Blue areas indicate continuous recording; green areas indicate event-triggered recording.
- When **Event recording** is selected, recordings can be triggered by “All events” or by specific event types, including camera DI, camera DO, motion detection, PIR, and tampering detection.

After configuring the settings, click **Save** to apply changes or **Cancel** to discard them.

Backup

The **Backup** page allows the system to create duplicate copies of recordings and store them in a designated backup volume. When enabled, selected cameras will back up their recordings to an FTP server according to the defined time frame.

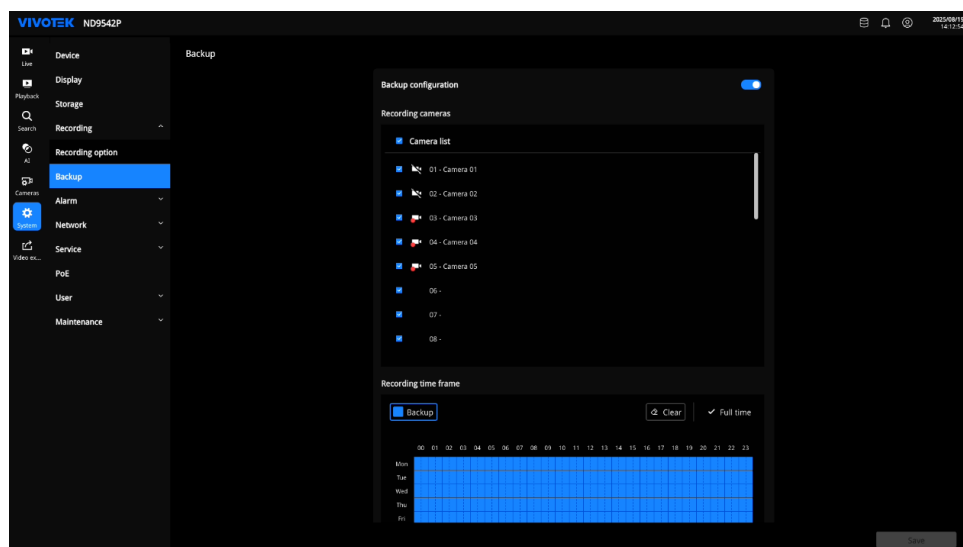

Backup Configuration

Move the switch on the Backup configuration panel to enable or disable the backup function. When enabled, the following options are available.

Recording Cameras

Select the cameras to be included in the backup task. Choose “All Cameras” to include all connected cameras, or select specific cameras from the list.

Recording Time Frame

Define when backup jobs will be performed. Select **Backup** and drag across the time grid to mark backup periods. Each block represents 30 minutes. Use **Clear** to remove marked periods or **Full time** to select the entire day. Blue areas indicate active backup periods.

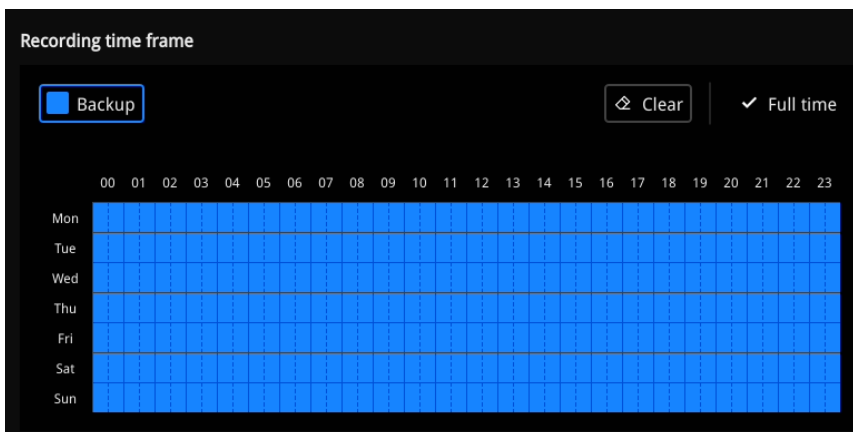

Daily Backup Time

Specify the time of day when the backup task starts.



FTP Server Settings

Enter the information for the destination server where backup files will be stored: server address, port number, and target folder path. Use **Test** to verify the connection before saving.

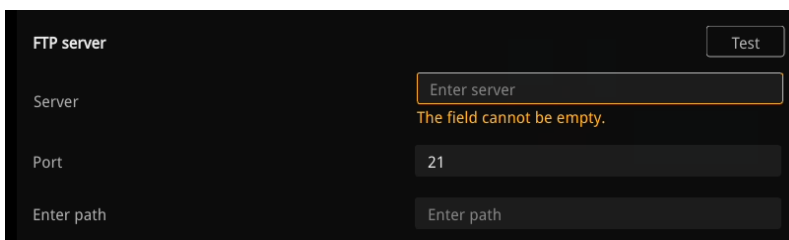

Authorization

If the FTP server requires login credentials, enable authorization and provide a username and password.

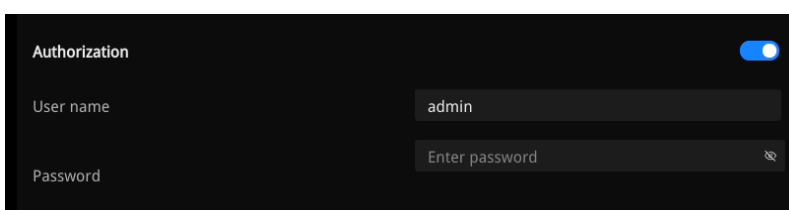

Upload Limit

Enable upload limit to restrict the maximum bandwidth (in Kbps) used by the backup process.

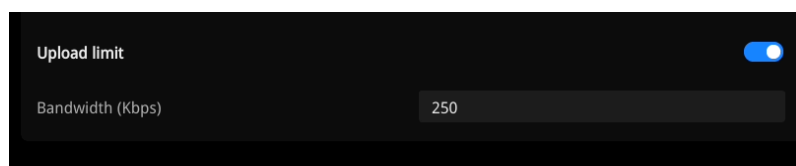

After completing the configuration, click **Save** to apply the settings. The system will then perform backups according to the defined schedule.

Alarm

The Alarm module allows configuration of event-triggered actions and notifications.

It consists of three sub-pages:

- **Alarm** – Create and manage alarm rules.
- **Recipient** – Define recipients for email notifications.
- **SMTP** – Configure the SMTP server for sending email alerts.

Alarm

The Alarm page allows configuration of alarm rules that define how the NVR responds to system events or camera events. All created alarms are listed on this page. Click **+ Add** to create a new alarm.

NOTE

Up to 20 alarm instances can be created.

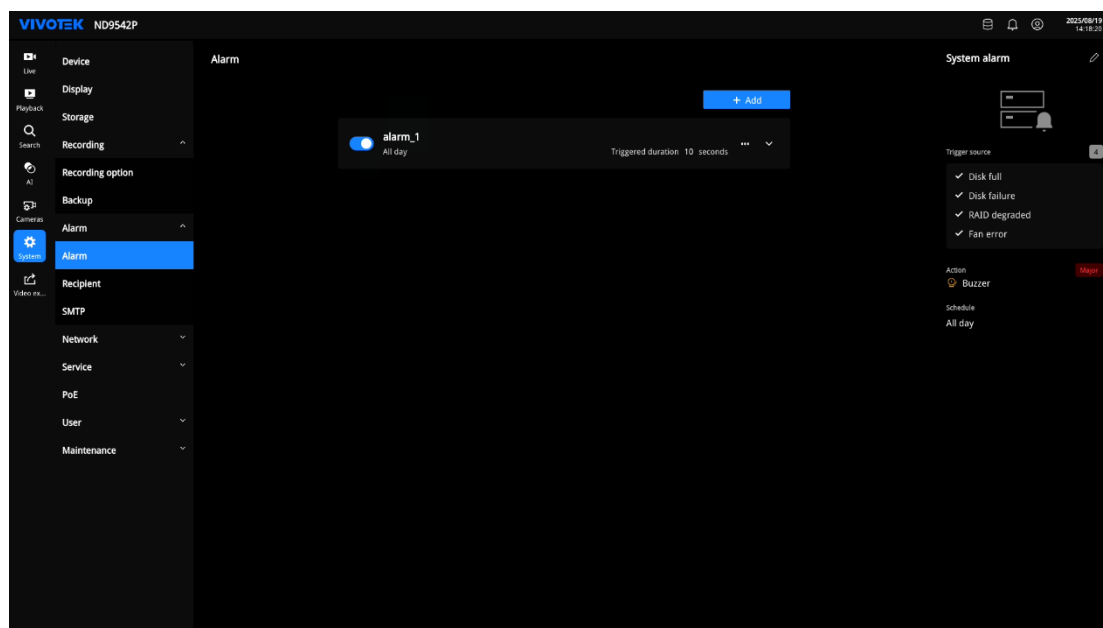

Create New Alarm

When **+ Add** is selected, the Create new alarm window opens. Configuring an alarm involves three steps: **Condition**, **Action**, and **Schedule**.

Condition

Specify an alarm name, select the trigger sources, and set the triggered duration.

- Trigger sources can come from the NVR, a camera, or system I/O signals.
- For NVR and cameras, available event categories include general events (DI/DO, PoE error, fan error), storage events (disk failure, disk full, RAID degraded), and Trend Micro IoT security events (brute force attack, cyber attack, quarantine event).
- Triggered duration defines how long the action remains active once the condition is met.

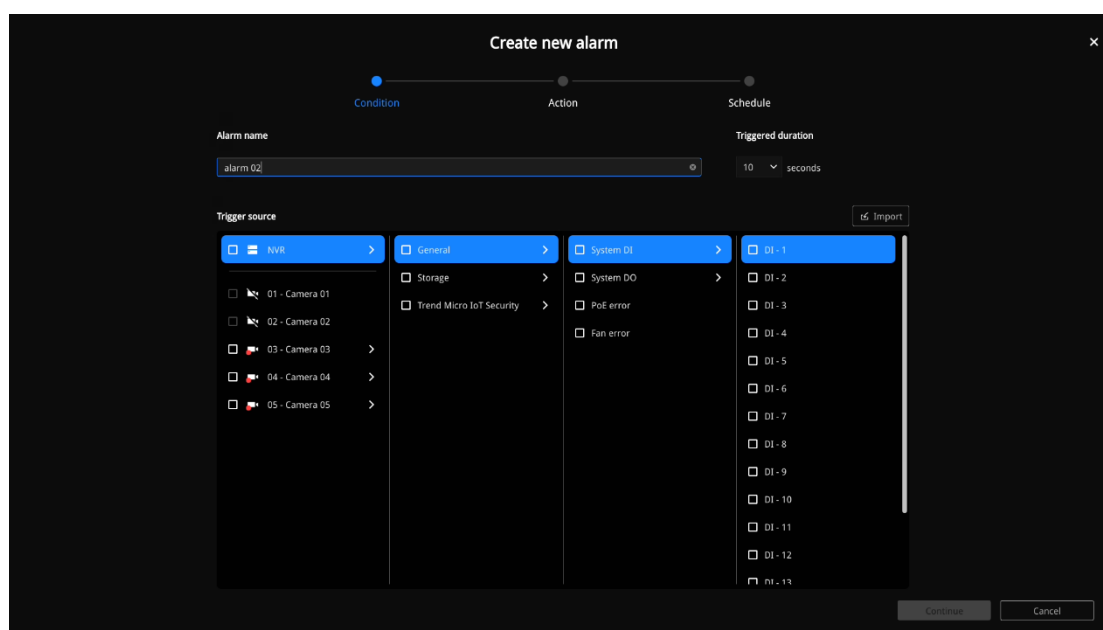

Action

After setting the condition, choose the action to be taken when the alarm is triggered. Available action types include:

- Video recording (specify which cameras will start recording)
- Send email (send notifications to configured recipients)
- FTP or HTTP upload
- Camera DO or System DO activation
- PTZ movement
- Buzzer (set severity level: Major, Normal, or Minor, and define the repeat time for buzzer alerts)
- Send video to full screen
- Send alarm information to VMS

Multiple action types can be configured as needed.

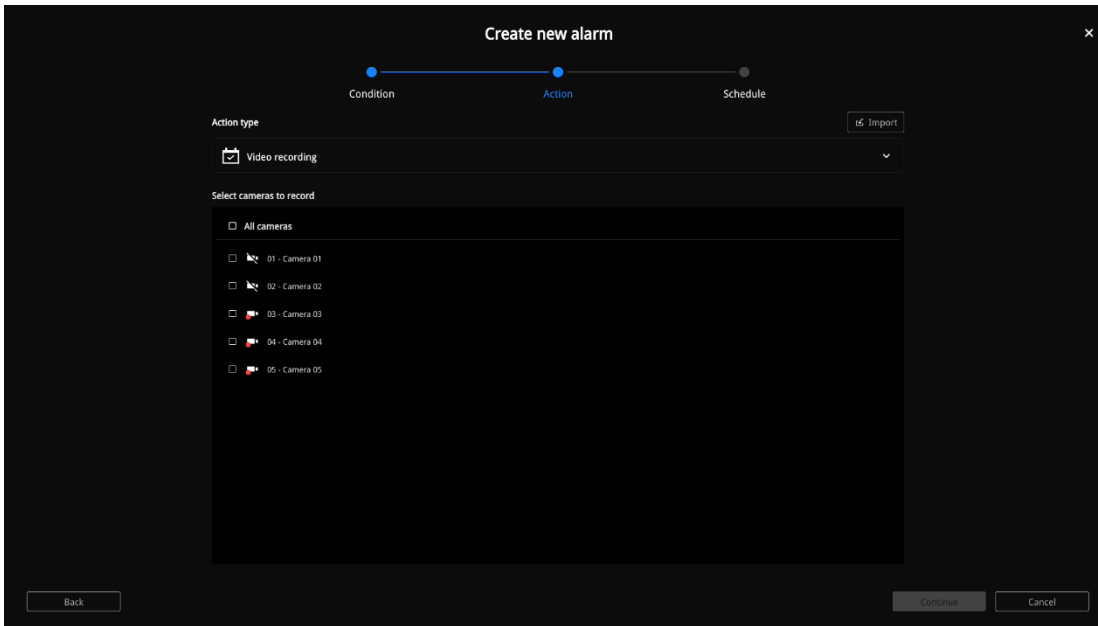

Schedule

Define when the alarm rule is active by selecting time blocks on the schedule grid.

- Drag on the grid to set the active time (each block equals 30 minutes).
- Use **Full time** to make the alarm active at all times or **Clear** to reset the schedule.

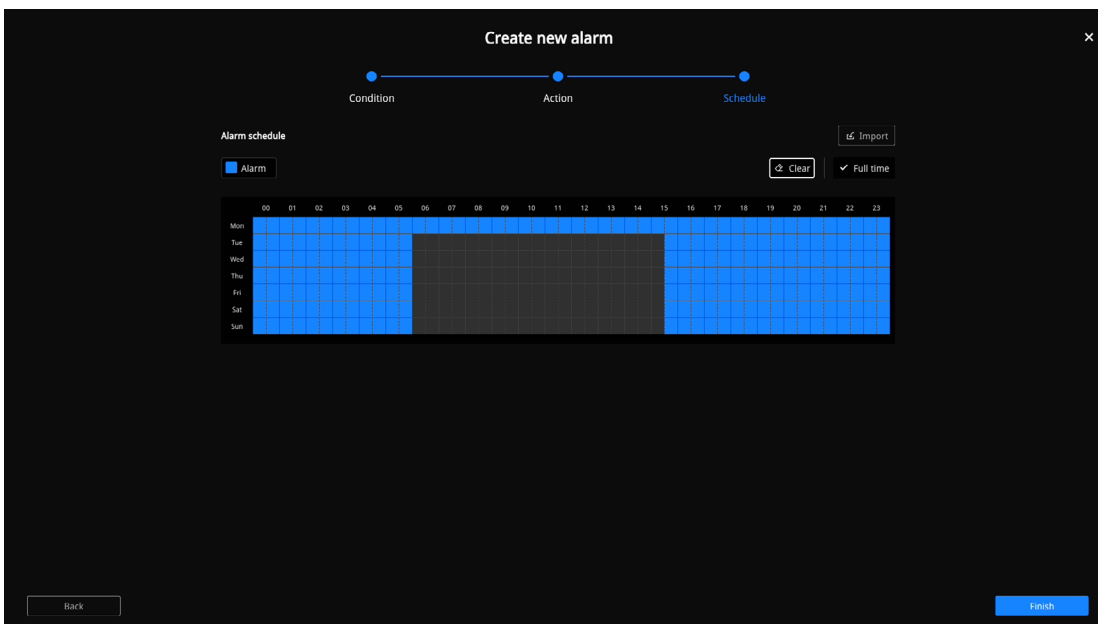

Click **Finish** to finish creating the alarm. The new alarm will appear in the list on the Alarm page.

System Alarm

In addition to user-defined alarms, the NVR provides a built-in **System alarm** function shown on the right side of the page. This alarm automatically triggers the internal buzzer when critical system conditions occur.

Click the edit icon  to select which system events will activate the buzzer. The available trigger sources include:

- Disk full
- Disk failure

- Fan error
- RAID degraded

The system alarm operates according to the pre-defined schedule and severity level.

Recipient

The Recipient page is used to manage the list of email recipients who will receive notifications when an alarm is triggered.

Add a Recipient

Click **+ Add** to open the Add a recipient window. Enter the following information:

- **Name:** A descriptive name for identifying the recipient.
- **Email:** The recipient's email address.

After filling in the required fields, click **Add** to save the recipient. Once added, the recipient appears in the list and can be selected when configuring email actions for alarms.

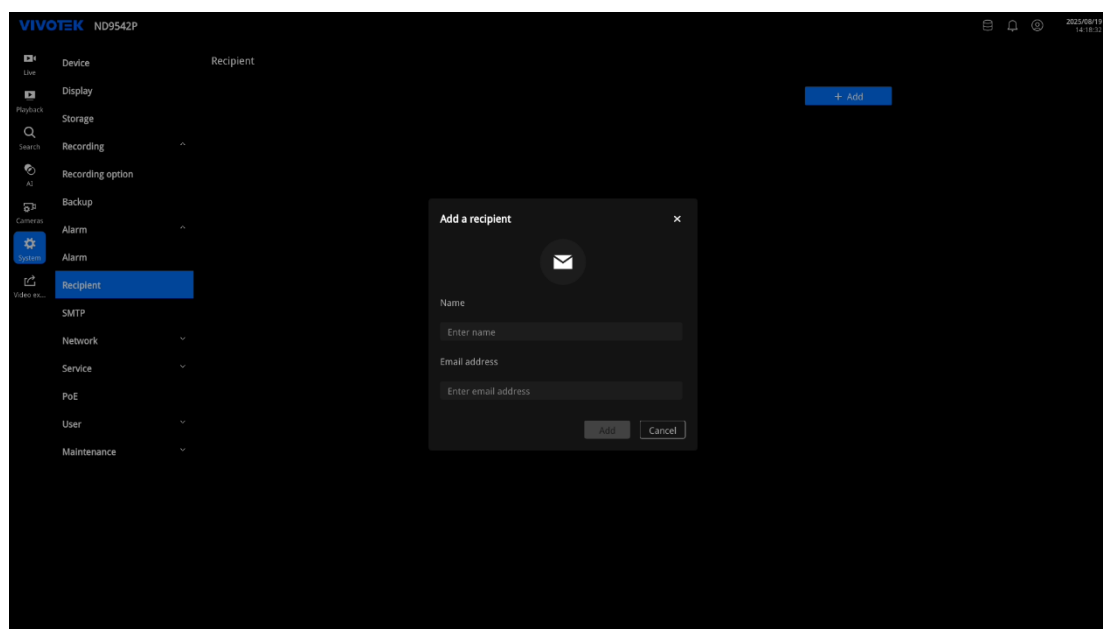

Managing recipients

All configured recipients are displayed in a table. The list includes the recipient's name and email address. Recipients can be edited or removed as needed.

Configured recipients are used in the Alarm settings when the **Send email** action type is selected.

SMTP

The SMTP page is used to configure the email server that will be used by the NVR to send alarm notifications.

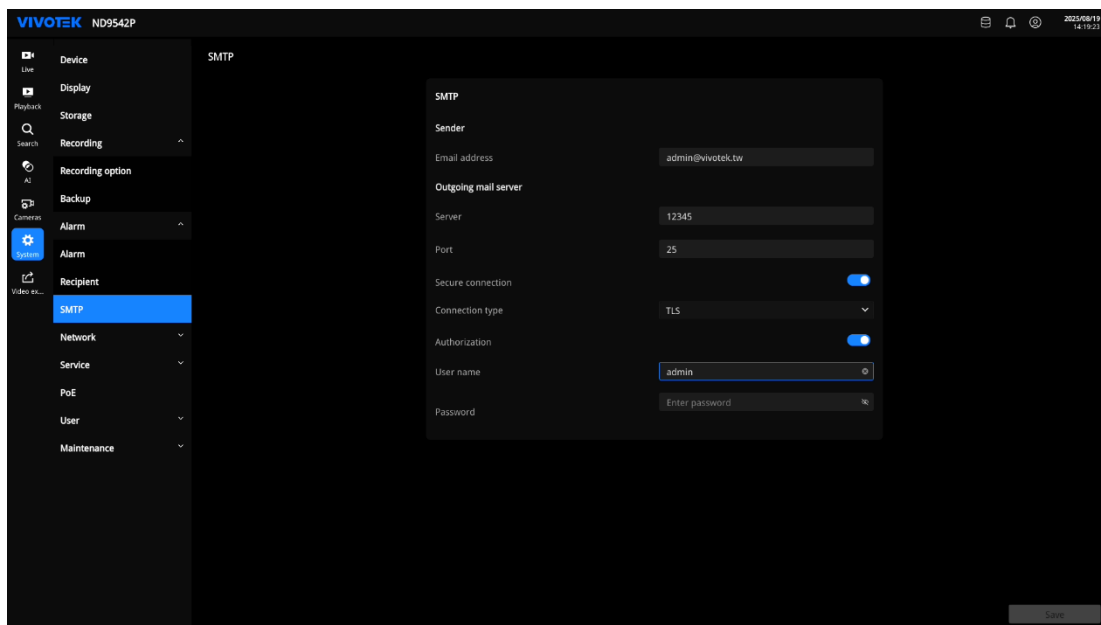

Sender

Specify the email address that will appear as the sender of alarm notification emails.

Outgoing Mail Server

Configure the details of the mail server:

- **Server:** Enter the address of the SMTP server.
- **Port:** Enter the port number used by the SMTP server (default is 25).

Secure Connection

Enable encryption for outgoing email. Select the connection type (TLS/SSL) from the drop-down list.

Authorization

If the SMTP server requires authentication, enable **Authorization** and provide a valid username and password.

After entering the required information, click **Save** to apply the settings. These SMTP settings are used whenever an alarm action is configured to send email notifications.

Network

The **Network** module provides configuration options for network connectivity and communication services. These settings define how the NVR connects to the local network and external systems, including IP configuration, port settings, and optional services such as DDNS.

Network Settings

The **Network Settings** page allows configuration of network parameters for the NVR, including interface settings, IP configuration, and communication methods. These settings define how the NVR connects to the local network and external services.

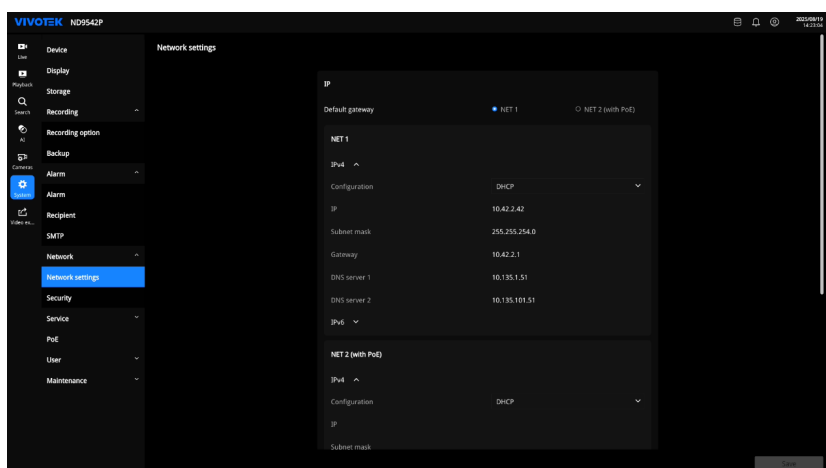

IP

The IP section configures the network parameters for the two available network interfaces: **NET 1** and **NET 2 (with PoE)**. One of the interfaces must be assigned as the **Default gateway**.

For each interface, both **IPv4** and **IPv6** can be configured separately.

IPv4

- **Configuration:** Choose between **DHCP** and **Manual setup**.
 - DHCP: The NVR automatically obtains network parameters from a DHCP server.
 - Manual setup: Specify the IP address, subnet mask, gateway, and DNS servers manually.
- **PoE DHCP server (NET 2 only):** When NET 2 is set to Manual setup, an additional DHCP server function can be enabled to assign IP addresses to PoE-powered devices connected to NET 2. The DHCP address range must be specified.

IPv6

- **Configuration mode:** Choose between Auto and Manual setup.
 - Auto: The system automatically obtains IPv6 settings from the network.
 - Manual setup: Specify the IPv6 address, prefix length, gateway, and DNS server manually.

NOTE:

1. The IP addresses for Net1 and Net2 must not be the same.
2. If the uplink port is connected to a 10.1.1.x network, the PoE subnet must be changed to the 192.168.2.x segment.
3. Although the system supports MAC Binding, VIVOTEK cameras within the network can still be detected regardless of the presence of a DHCP server.

Port Settings

The **Port Settings** page defines the network service ports used by the NVR. These settings are used by clients or applications when connecting to the NVR.

The following ports can be configured:

- **HTTP:** Port number used for unencrypted web access.
- **HTTPS:** Port number used for secure web access via HTTPS.
- **RTSP:** Port number used for RTSP streaming.
- **iViewer:** Port number used by iViewer client connections.

DDNS

The DDNS (Dynamic Domain Name System) page allows the NVR to be accessed through a fixed domain name even when the network uses a dynamic IP address.

To enable DDNS, move the **DDNS** switch to ON and enter the following information:

- **Provider:** Select the DDNS service provider from the drop-down menu.
 - Dyndns.org (Dynamic)
 - Dyndns.org (Custom)
- **Host name:** Enter the registered host name assigned by the DDNS provider.
- **User name:** Enter the account user name for the DDNS service.
- **Password:** Enter the password for the DDNS service account.

After completing the configuration, click **Save** to apply changes.

Security

The **Security** page provides options to manage HTTPS certificates for encrypted connections and to enable Trend Micro IoT Security services on the NVR.

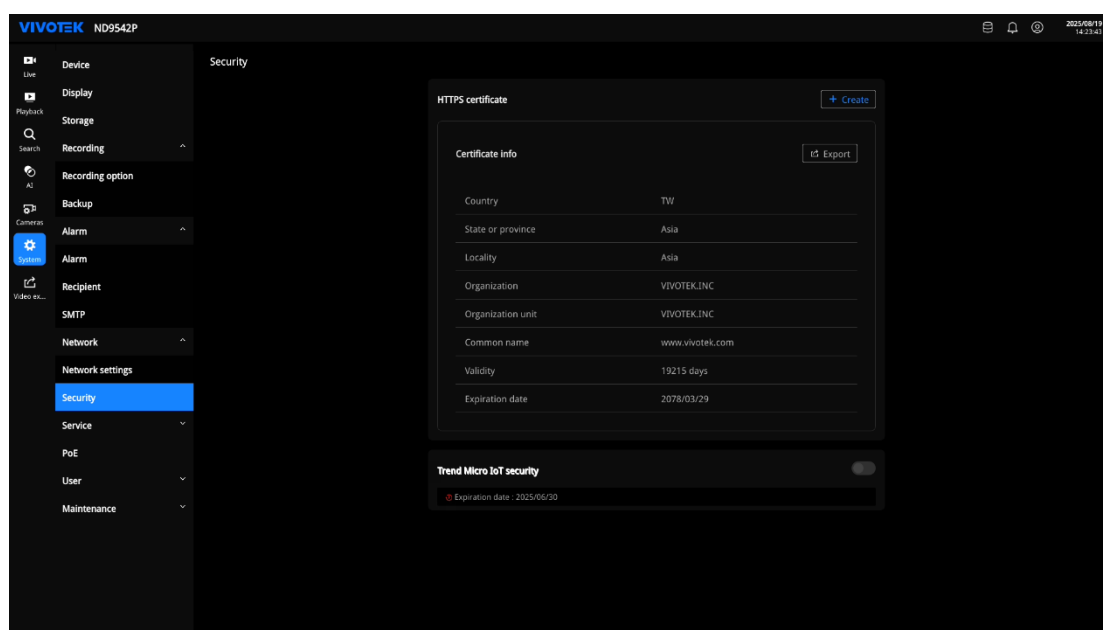

HTTPS Certificate

This section lists the details of the HTTPS certificate currently installed on the NVR, including: country, state of province, locality, organization, organizational unit, common name, validity period, and expiration date.

Create New Certificate

Click "+ Create" to open a window to add a new certificate. Three options are available:

- **Create self-signed certificate** – Generates a certificate signed by the NVR.
- **Create a certificate request** – Generates a CSR (Certificate Signing Request) for submission to a Certificate Authority.
- **Import new certificate** – Uploads an existing certificate to the NVR.

Export

Downloads the installed certificate.

These certificates are used to secure HTTPS connections to the NVR.

Trend Micro IoT Security

This section enables the Trend Micro IoT Security (TMIS) service, which adds additional protection and threat intelligence features.

When TMIS is enabled, the page displays security information including:

- Expiration date
- Signature version
- Signature update mode (Auto or Manual)
- Keep event data (retention period)

The **Settings** button provides access to license details and related options.

If TMIS has expired, a warning is displayed, and security protection will no longer be active until the license is renewed.

Service

The Service module provides cloud connection features and companion service settings for system integration and remote management.

VORTEX Connect

VORTEX Connect allows the NVR to be linked with the VIVOTEK VORTEX cloud service for remote access and management.

The page displays:

- **Cloud connection status:** Indicates whether the NVR is successfully connected to the VORTEX cloud.
- **Organization binding status:** Shows whether the NVR is bound to an organization account.
- **Device ID and QR code:** Provides the unique identifier and QR code for onboarding.

To activate VORTEX Connect, use the provided QR code or Device ID with the VORTEX mobile app or portal as instructed.

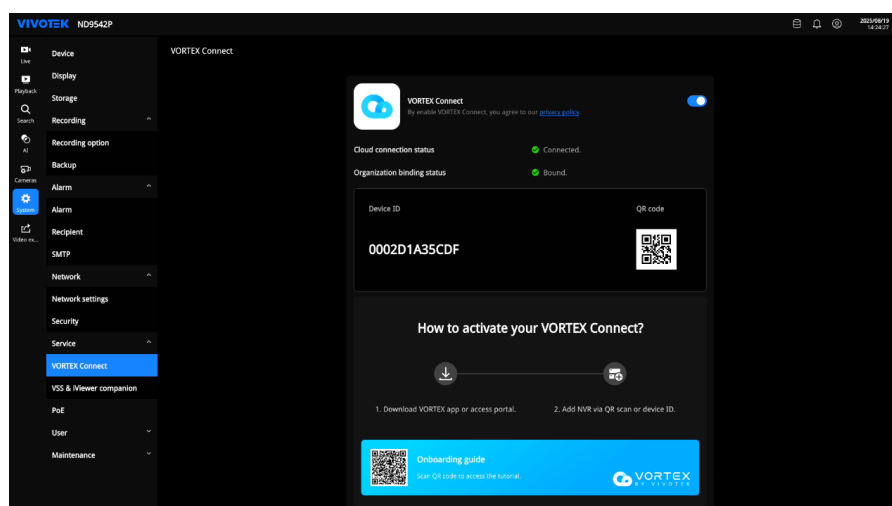

VSS & iViewer Companion

This section enables the companion service that integrates the NVR with VSS (VIVOTEK VSS platform) and iViewer applications.

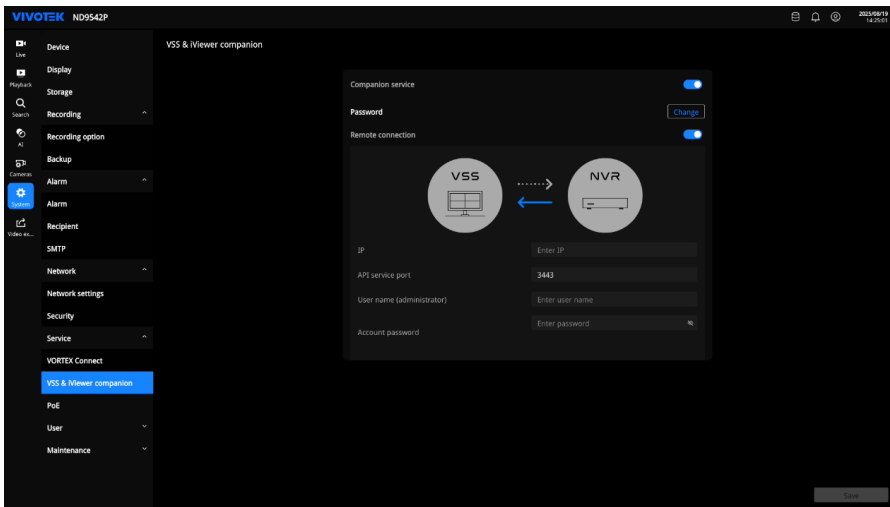

- **Companion service:** Enable or disable the companion service.
- **Password:** Set or change the companion service password.
- **Remote connection:** Configure parameters for remote connection to VSS.
 - **IP:** Specify the VSS server IP address.
 - **API service port:** Define the port used for API communication.
 - **User name and Account password:** Enter administrator credentials for the VSS server.

After configuring these settings, click **Save**. The NVR can then be accessed and managed by VSS or iViewer over the specified connection.

PoE

The **PoE** module allows monitoring and configuration of Power over Ethernet (PoE) ports on the NVR. This feature provides power to connected cameras through network cables and displays power consumption in real time.

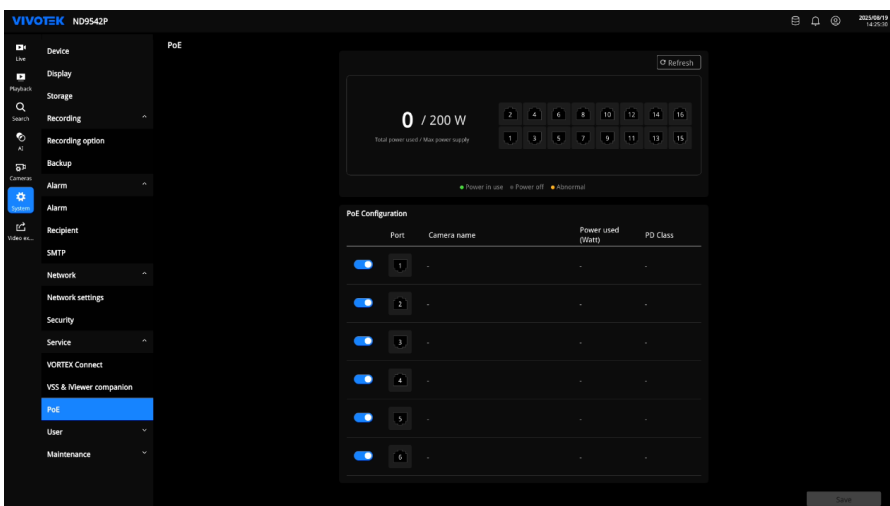

PoE Status

The **PoE Status** card displays the total power usage and the maximum available power supply.

Each port icon shows its status:

- **Green** – Power in use
- **Gray** – Power off
- **Red** – Abnormal

Click **Refresh** to update the current status.

PoE Configuration

The **PoE Configuration** card lists each PoE port with the following information:

- **Port:** Port number of the PoE interface.
- **Camera name:** The name of the camera connected to that port (if applicable).
- **Power used (Watt):** The current power consumption on that port.
- **PD Class:** The detected power device class.

Use the switch next to each port to enable or disable PoE power output. After making changes, click **Save** to apply the settings.

User

The User module provides centralized management of all user-related settings. From this section, administrators can access account lists, manage login rules, and configure session timeout behavior. The module ensures proper account control and system security by separating account administration from authentication and timeout policies.

User

This page displays all existing user accounts on the NVR. It provides details such as username, assigned role, and password strength. The system administrator can create new accounts, assign appropriate roles, reset passwords, and modify existing account information. This function allows fine-grained control of system access and privileges.

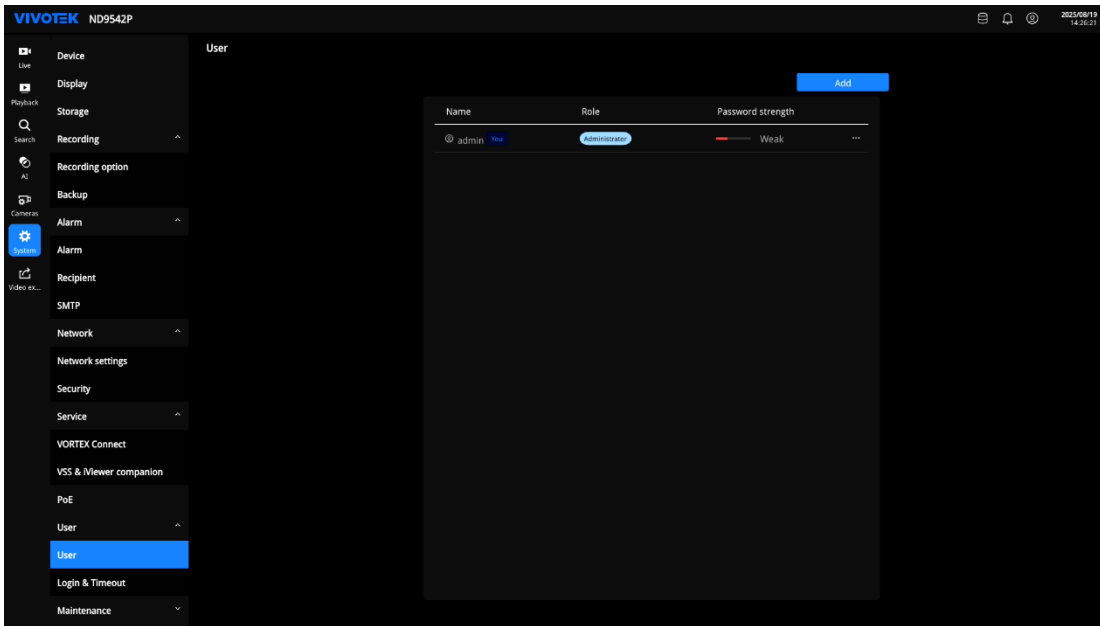

Steps to Add a User

1. Click **Add** to open the **Add a user** window.

Enter the following information:

- User name
- Password and re-enter the password (must meet the system's password policy requirements)

2. Select a role from the drop-down menu:

- **Administrator** – Grants full access and control over all functions.
- **Regular** – Grants standard user privileges with limited access.

3. Click **Add** to save the new user.

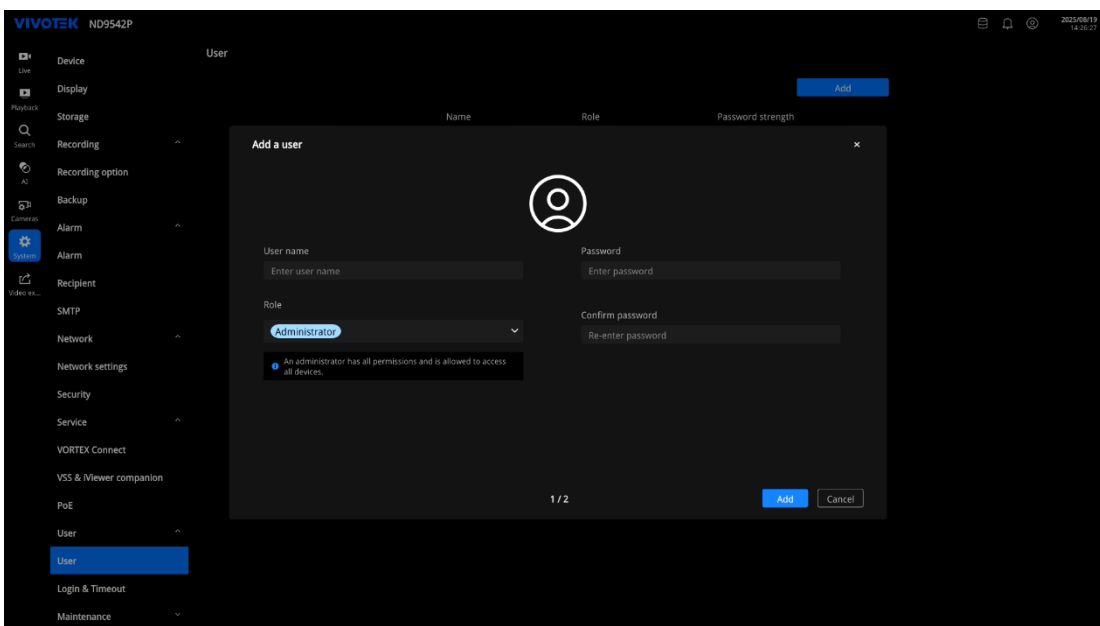

Steps to Edit a User

1. In the User list, click the menu icon (...) next to the target account and select **Edit**.
2. Update the necessary information:
 - Change the password by selecting **Change password** and entering the new password.
 - Note: The user role cannot be modified for the default administrator account.
3. Click **Save** to apply the changes.

Password Strength

The **Password strength** column displays the quality of the password as Weak, Medium, or Strong, depending on the complexity of the configured password.

Login & Timeout

This page configures login behavior and session timeouts for the NVR.

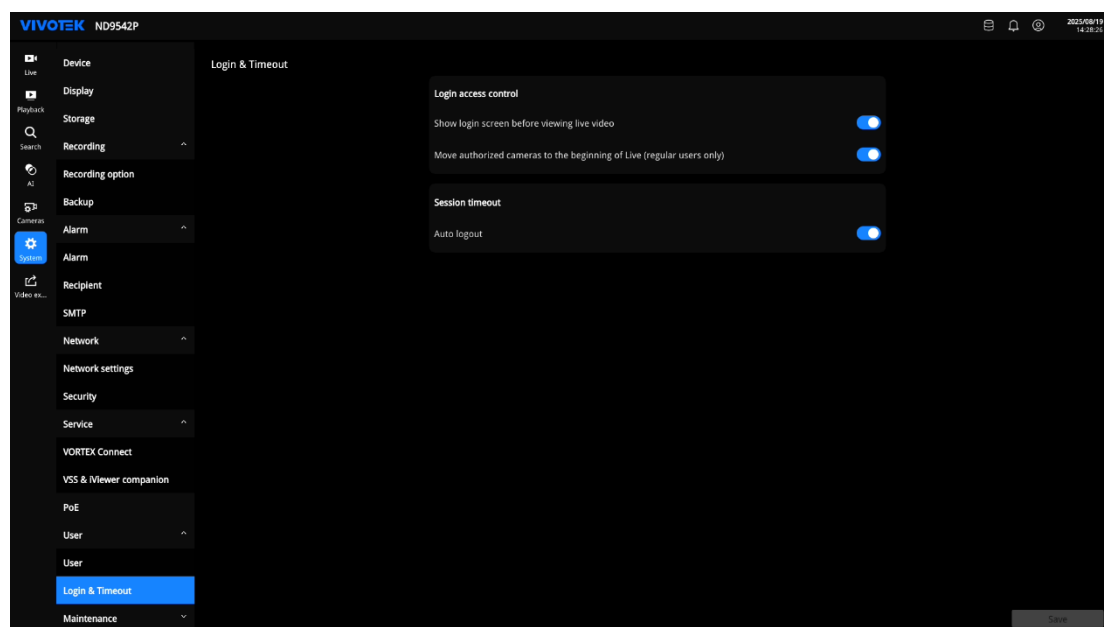

Login Access Control

Enable or disable the following options to control how authentication and channel ordering behave.

Show login screen before viewing live video

When enabled, the login screen appears before any live video is displayed. This ensures that no live streams are shown until valid account credentials are entered.

Move authorized cameras to the beginning of Live (regular users only)

When enabled, cameras that the signed in account is authorized to view are placed at the beginning of the Live view list. This improves access efficiency for regular users with limited permissions. Administrator accounts are not affected.

Session Timeout

Auto logout

When enabled, the current session is automatically signed out after a period of inactivity. Use this setting to reduce the risk of unattended consoles remaining logged in.

Maintenance

The **Maintenance** module provides functions to update firmware, manage device packs, back up and restore configurations, reboot or shut down the system, and perform a factory reset. These tools help maintain system performance and ensure reliable operation.

System Maintenance

The **System Maintenance** page provides tools for updating, backing up, and restoring the system, as well as options to reboot, shut down, or reset the NVR.

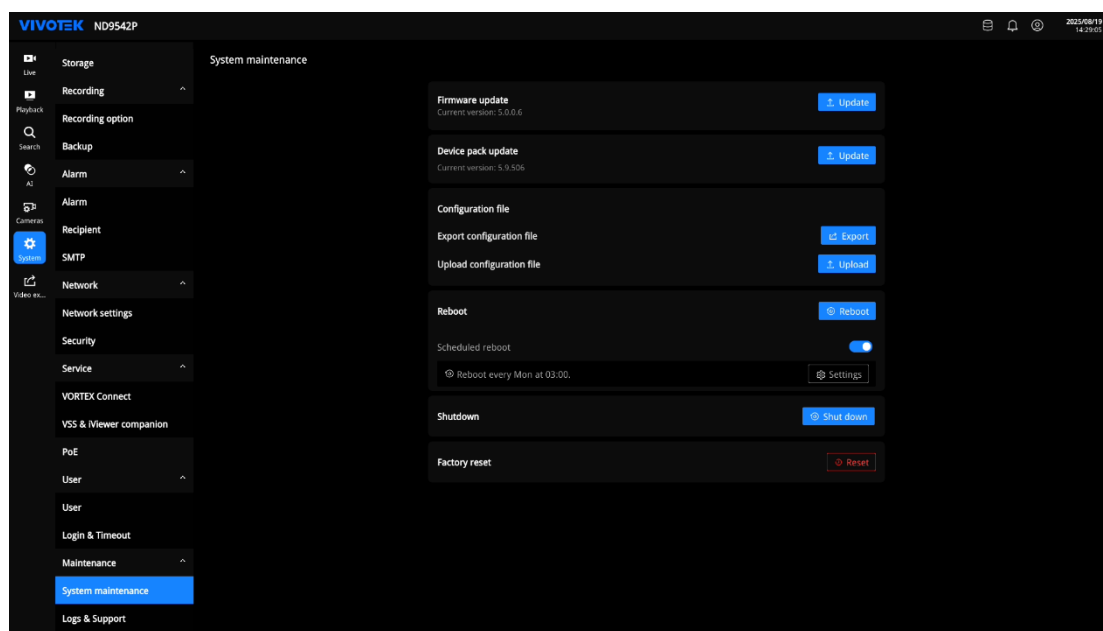

Firmware Update

The card displays the model name and the current installed firmware version. To update firmware, choose either **Cloud update** or **Local update**.

- Cloud Update
Click **Update** to install the latest available firmware. The system automatically downloads and applies the update.
- Local Update
Click **Upload** to select a new firmware file from your device and start the update process.

IMPORTANT

Systems running firmware version 4.7 or 5.0 cannot be downgraded to version 4.6 or earlier.

Device Pack Update

Displays the current device pack version. Click **Update** to upload the latest device pack file.

Configuration File

- Export configuration file: Saves the current system configuration to a file.
- Upload configuration file: Restores system settings from a previously exported configuration file.

Reboot

The **Reboot** card allows a manual reboot or the configuration of a scheduled automatic reboot.

Click **Settings** to open the **Scheduled Reboot** configuration window. Select the desired time and days of the week, then click **Save**.

Shut Down

Click **Shut down** to safely power off the NVR.

Factory Reset

The **Factory Reset** option restores the NVR to its original factory default settings. Selecting **Reset** opens the **Exception** window, where specific configuration items can be retained during the reset process.

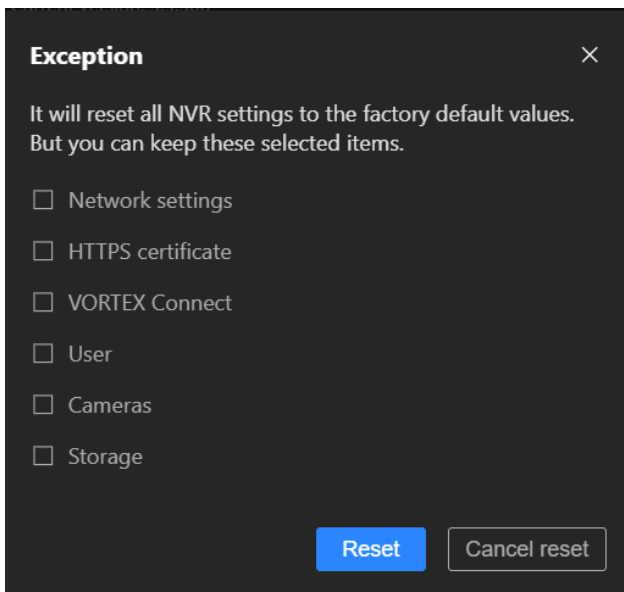

The following items can be preserved if selected:

- Network settings
- HTTPS certificate
- VORTEX Connect
- User accounts
- Cameras
- Storage

To proceed, select the desired exceptions, then click **Reset**. To cancel the process, click **Cancel reset**.

NOTE

The physical Reset button on the device can be used to restore the system to its default settings. Press and hold the button for more than 5 seconds to initiate the reset process. (For illustrations of the button, refer to Appendix A and Appendix B.)

Logs & Support

The **Logs & Support** page allows reviewing system logs, enabling remote support access, and exporting debug logs for troubleshooting purposes.

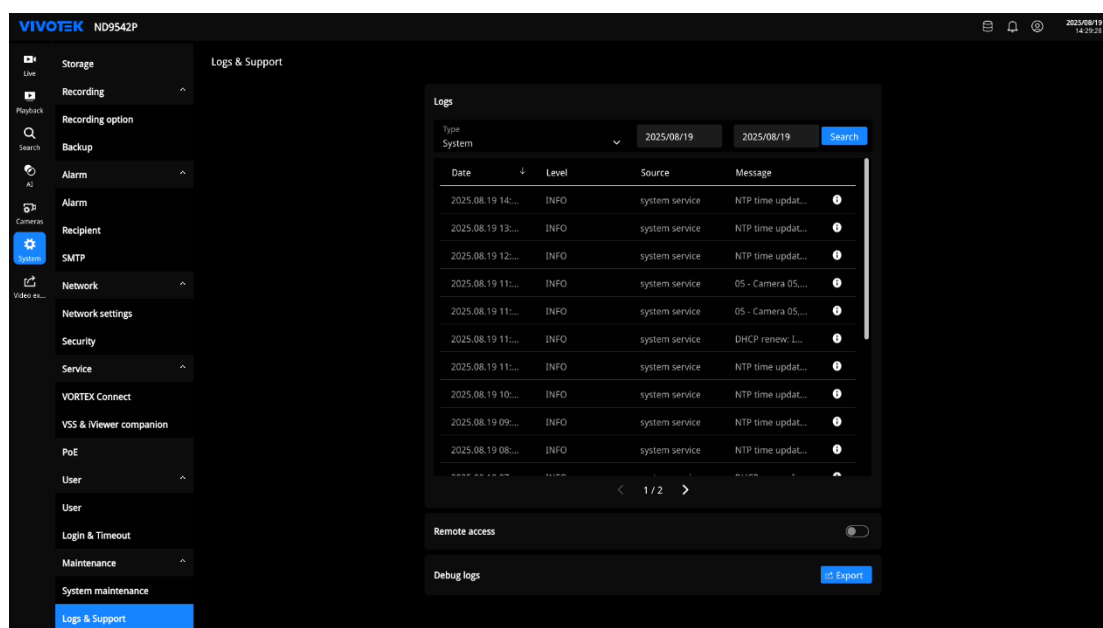

Logs

To display logs, select the log type (system, recording, user, error) and time frame, and then click **Search**. The results list includes the date, severity level, source, and a description of the event.

When the information icon next to a log entry is clicked, the **Log info** window opens. This window provides detailed information about the selected log, including:

- Date and time of the event
- Event level (severity)
- Source (e.g., which user or system component triggered the event)
- Message details describing the action or configuration change

Remote Access

Remote access provides a secure way to allow technical support to access the NVR for diagnostics. The page displays the connecting status, access ID, and expiration date of the session.

Debug Logs

Click **Export** to generate a debug log file, which can be used for further analysis by technical support.

Video Export (Local Only)

The **Video Export** function in the Local Console allows exporting recorded footage from one or multiple cameras to an external USB storage device. This feature is not available in the Web interface. It is useful for creating backups or sharing specific video clips without accessing the full recording.

External Storage Requirements

- When an external USB 3.0 storage device is connected, the maximum supported volume size is 16 TB. The NVR supports external enclosures with up to five disk drives. The minimum supported storage size is 64 GB.
- Power on the external storage device before turning on the NVR.
- Hot-swapping is not supported. If the external storage device is disconnected, recording continues on the NVR's internal disk drives.
- The storage configuration of the external enclosure, such as RAID, must be managed independently. To the NVR, a RAID volume appears as a single large disk drive, from which a recording volume must be created on the Storage configuration page.
- If the disk drives in the external enclosure are not configured as NVR storage volumes, they can be used as external backup devices. To do so, format the drives in FAT32 or NTFS, and then export recorded video from the NVR to these drives.

Configuring the Export

1. Open Video Export

Click the Video export icon in the navigation panel. If a storage volume exists on the NVR and a USB drive is inserted, the configuration dialog appears.

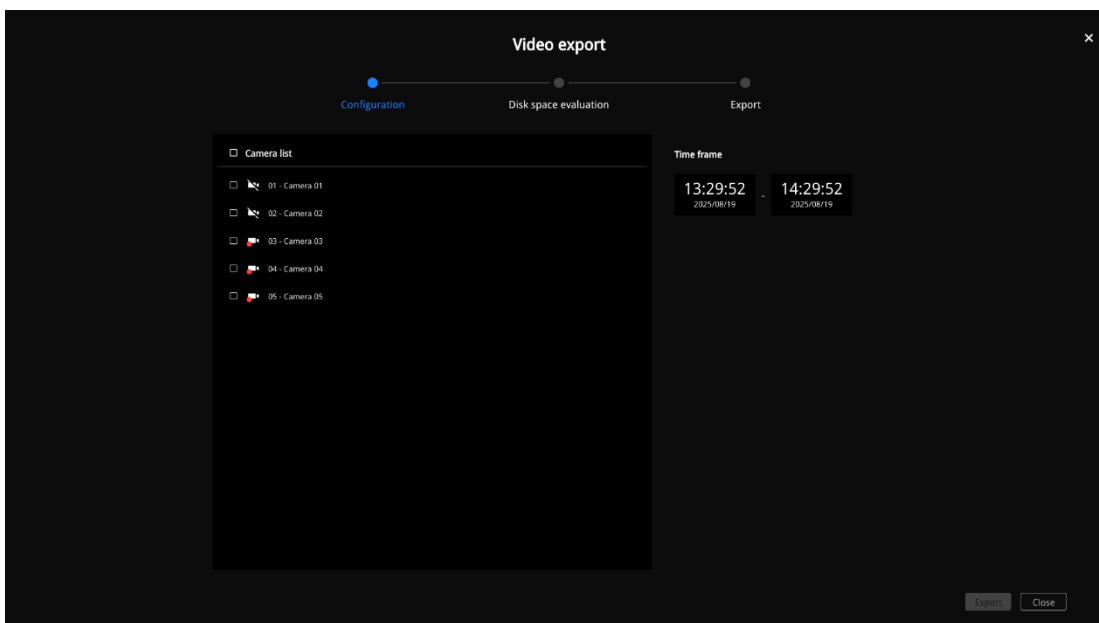

2. Select Cameras

The Camera list displays all channels in ascending order (CH01, CH02, etc.) and only shows cameras the logged-in user has permission to access. To include all cameras, enable All cameras; otherwise, select individual cameras from the list.

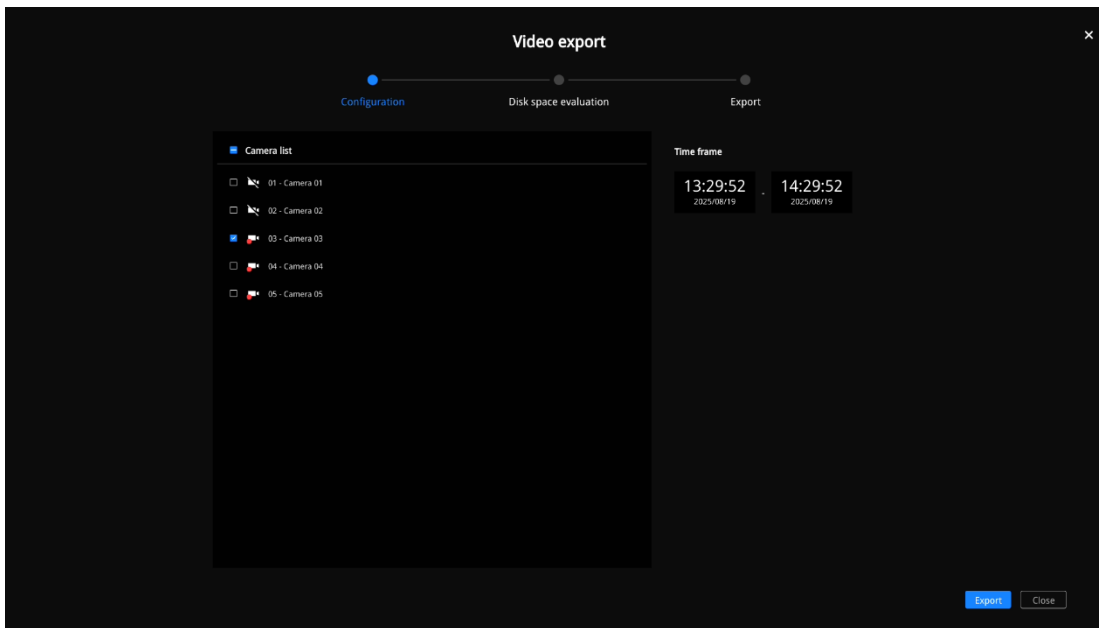

3. Set Time Frame

Define the start and end date/time for the export range. Clicking the date fields opens the calendar, where the system automatically adjusts the start or end time based on the selection order. The export time range is not subject to the 24-hour limitation.

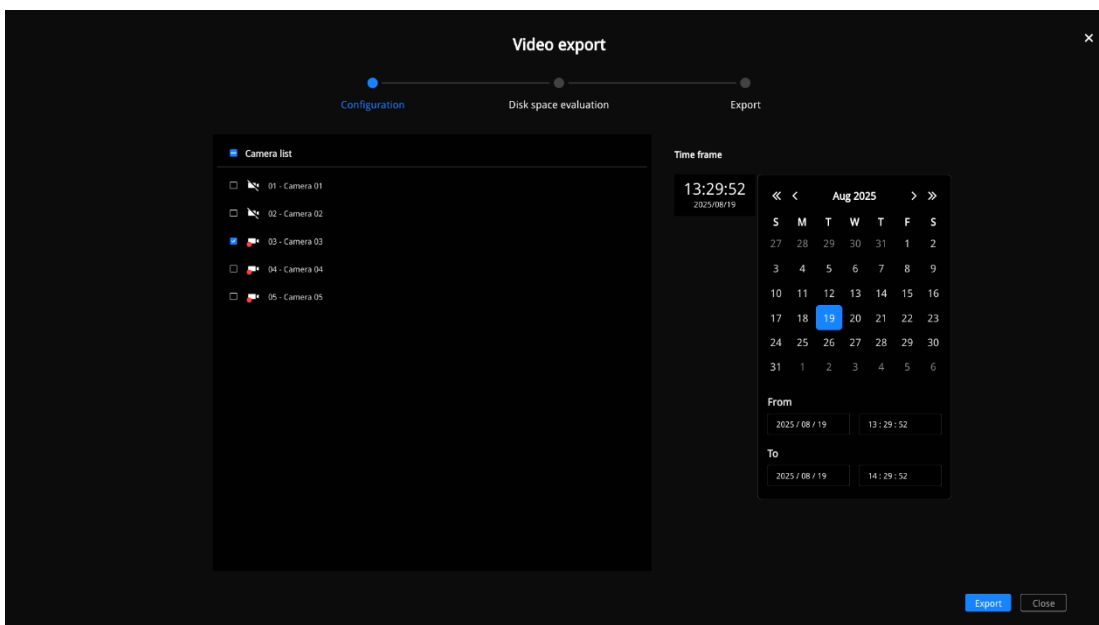

4. Proceed to Disk Space Evaluation

Click **Export** to continue. The system calculates the required and available USB storage capacity before starting the process.

Disk Space Evaluation

When storage is sufficient, the export process starts immediately. If the USB drive does not have enough space, the page displays the required capacity and the available capacity on the device. From here, the user can try recalculating the space or return to the configuration step to adjust the export parameters.

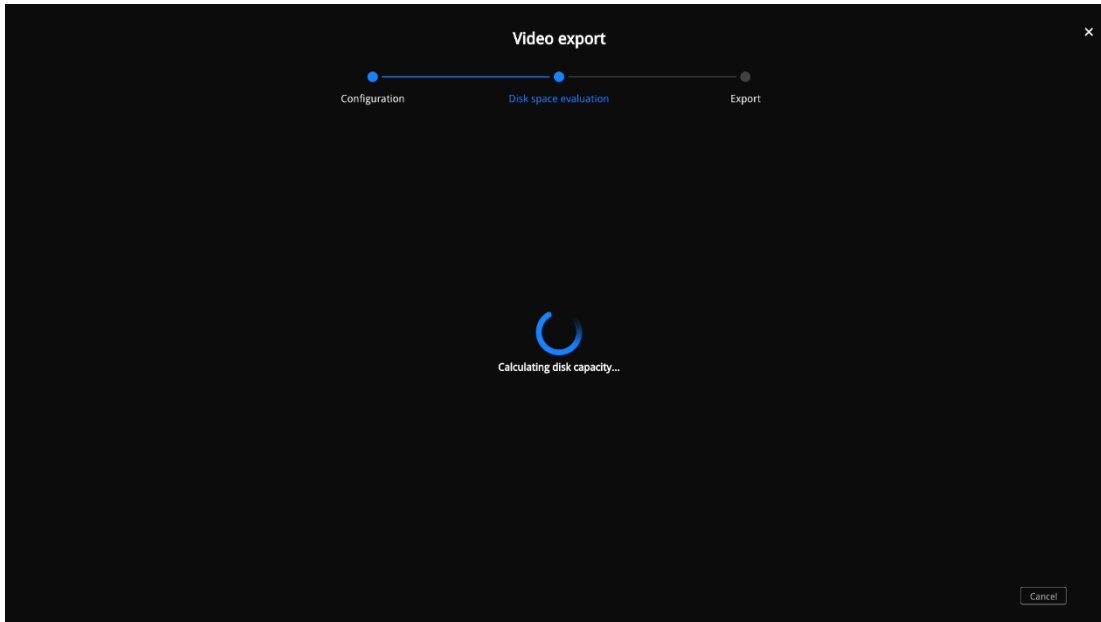

Exporting Footage

Once capacity is confirmed, the export begins. The interface shows the progress and estimated remaining time.

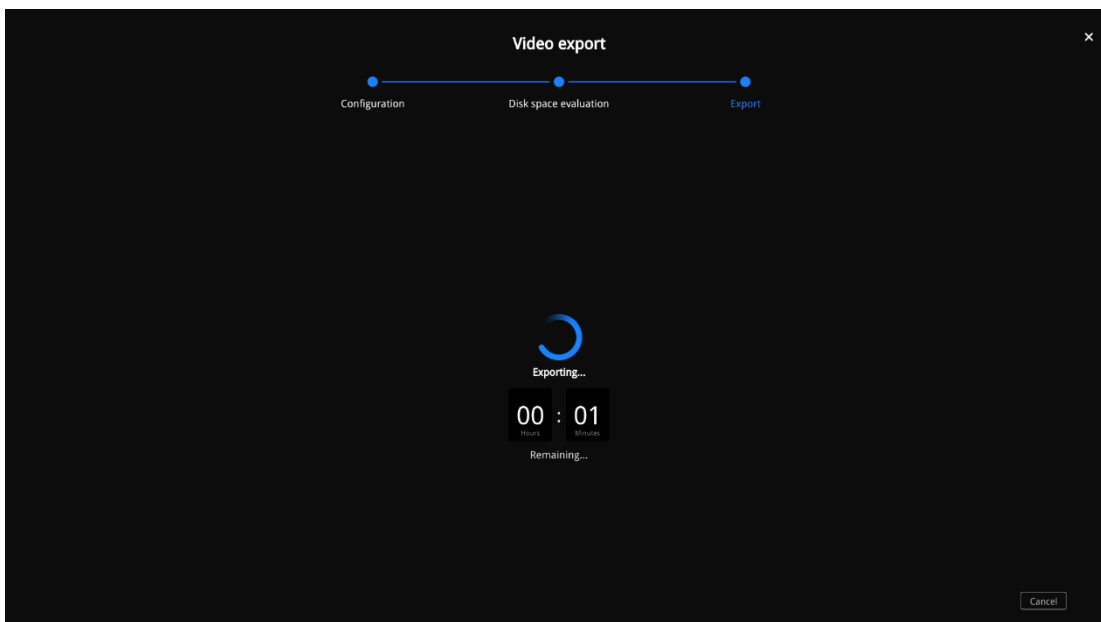

Completion Status

When the export finishes successfully, a confirmation message appears; selecting **Done** closes the process and returns to the Video export page. The exported files can then be found in the connected USB storage. If the export fails, the page provides options to retry or return to the configuration step.

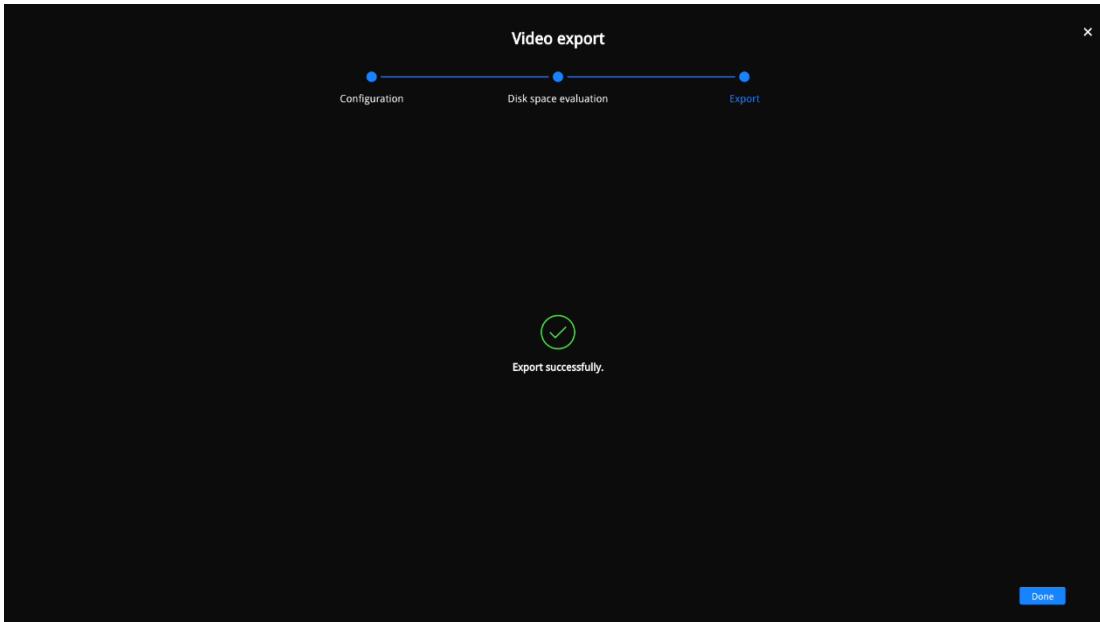

Appendix

A. Physical Overview (ND9442P / ND9542P)

Chassis Dimensions

Front View

Rear View

Quick Installation Guide (ND9442P / ND9542P)

AM-612 Rack Mount Rail Installation

B. Physical Overview (ND9326P / ND9426P)

Chassis Dimensions

Front View

Rear View

Quick Installation Guide (ND9326P / ND9426P)

C. Using Device Manager and Shepherd

Using Device Manager to Locate and Identify NVR on the LAN

Using Shepherd to Locate and Identify NVRs on the LAN

D. Safety and Compliance

Safety Instructions

Regulatory Compliance

Licensing Notices

A Physical Overview (ND9442P / ND9542P)

Chassis Dimensions

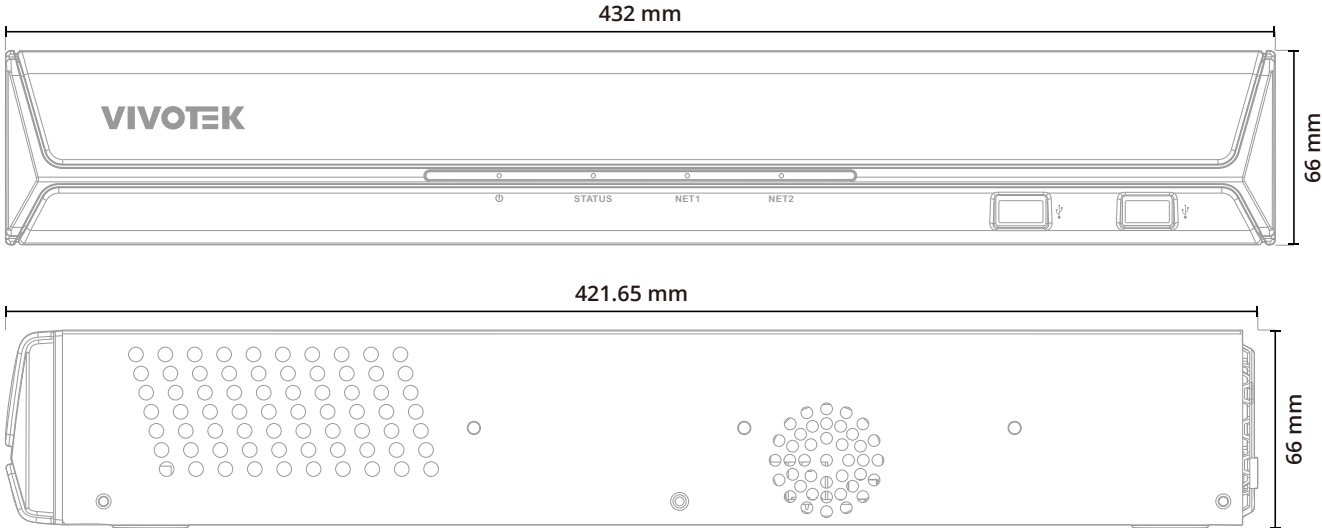

Front View

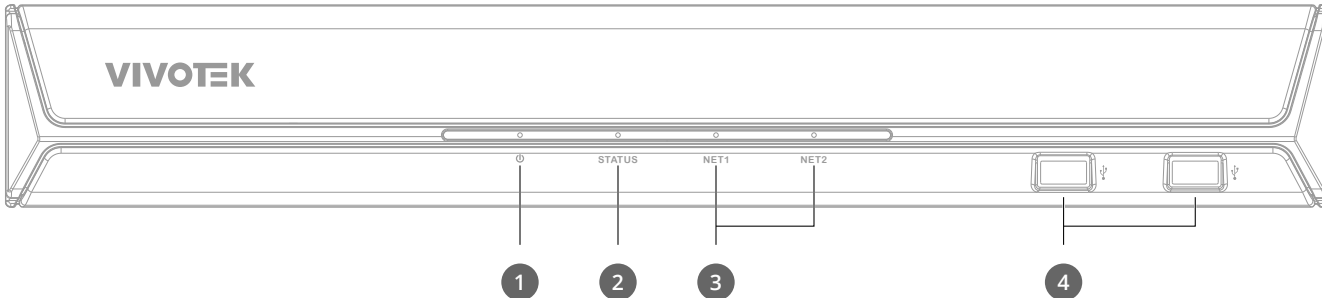

- 1 System power status
- 2 System status LED
- 3 Network uplink status/activity LED
- 4 USB 3.0 port

LED Indicators

No.	Name	Behavior	Definitions
1	NET LED	Blinking (Amber)	Data is being transmitted or received.
		OFF	The Ethernet uplink is disconnected.
2	Status LED	Constant (Green)	System ready.
		Blinking (Green) every 1 second	Updating firmware or device pack.
		Constant (Red)	1. S.M.A.R.T.-related disk errors. 2. A configured H.D.D. is missing. 3. H.D.D. is full. Buzzer will also be sounded. When buzzer is turned off, LED will return normal.
3	Power LED	Solid (Red)	The NVR is powered on.
		OFF	The NVR is powered off.

Rear View

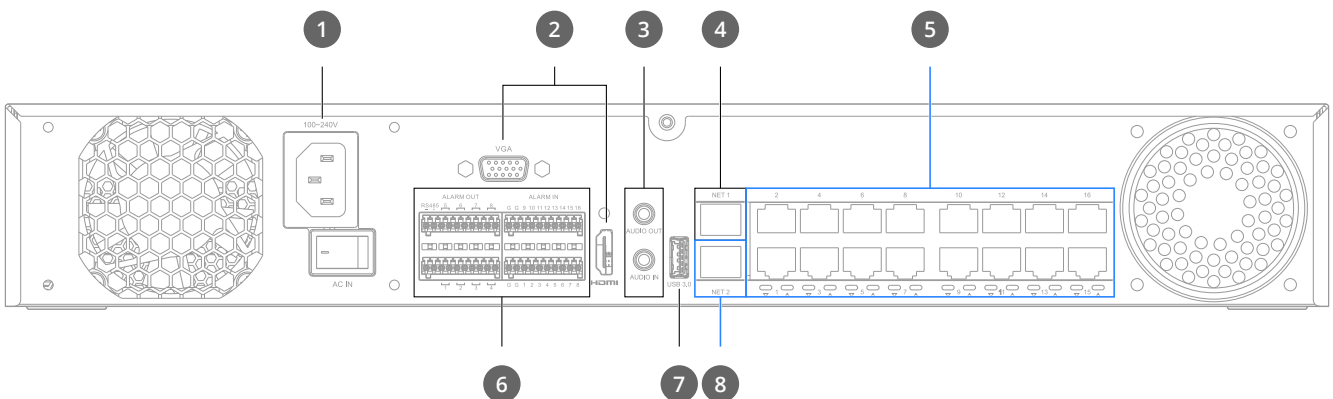

- 1 AC100~240V 50/60Hz
- 2 Monitor
- 3 Audio IN/OUT
- 4 NET 1
- 5 #1~16 PoE ports
- 6 DI/DO
- 7 USB 3.0
- 8 NET 2: NET 2 and PoE ports are in the same network

- Connect to a monitor using an HDMI cable. VGA is also supported.
- Connect CAT5e or better-quality Ethernet cable to the GbE Ethernet port.
- Connect USB devices such as, mouse, keyboard, USB optical drive, or USB thumb drive (formatted in FAT format), or joystick.
- Connect external devices, such as sensors, relays, or alarms to the terminal block.

- Connect the system to the power supply.
- PoE ports are in the same network domain as NET 2.
- If you connect external USB storage, connect it to the USB 3.0 port (at the back of the chassis).

Please do not connect the NVR's PoE ports to non-PD* devices (such as an Ethernet switch LAN port). The Ethernet control circuits may not be compatible.

* PD = A Powered Device designed to receive power source from a PoE connection such as network cameras.

Terminal Block Connections

The terminal block pinouts are shown as follows:

The relay pins default status is set to Normally Open. Connect your relay or external devices' signal wires to the system, the system will automatically detect the current signal status. You can then trigger the external devices using the DI/DO panel on the live view.

You can also configure the system alarm setting for the system to automatically trigger a relay pin on the occurrence of system events.

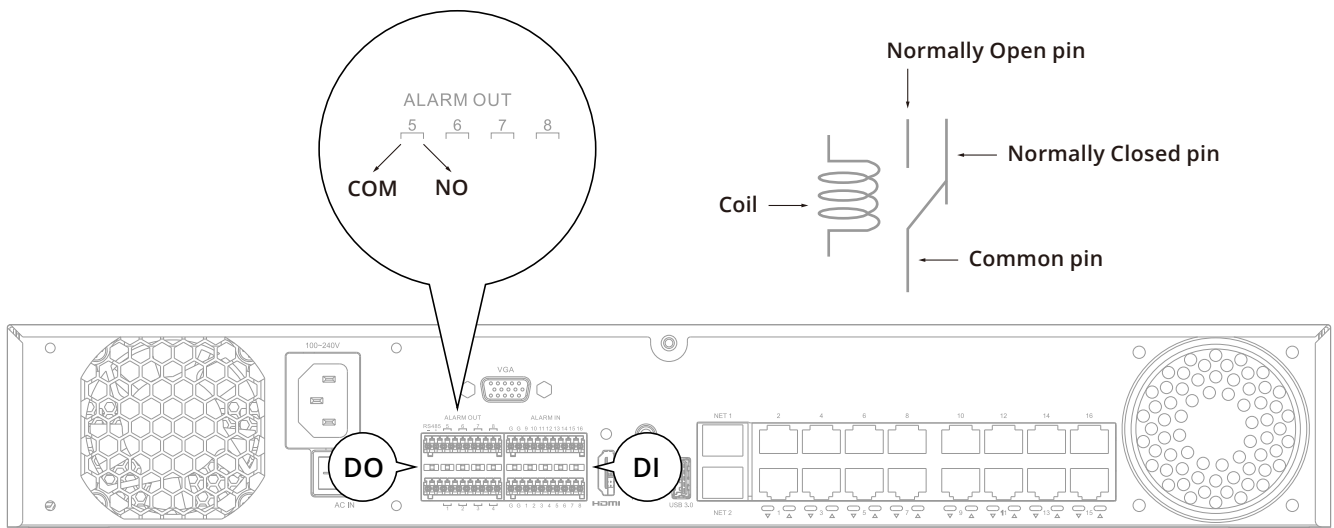

DO

1	NO1	5	NO5	RS485	Data+
	COM1		COM5		RS485
2	NO2	6	NO6		
	COM2		COM6		
3	NO3	7	NO7		
	COM3		COM7		
4	NO4	8	NO8		
	COM4		COM8		

A 120Ω terminator is enabled on the bus. The terminator cannot be disabled.

DI

G	Pins #1~8 share a common ground.	G	Pins #9~16 share a common ground.
G		G	
1	DI1 (ALARM IN)	9	DI9 (ALARM IN)
2	DI2 (ALARM IN)	10	DI10 (ALARM IN)
3	DI3 (ALARM IN)	11	DI11 (ALARM IN)
4	DI4 (ALARM IN)	12	DI12 (ALARM IN)
5	DI5 (ALARM IN)	13	DI13 (ALARM IN)
6	DI6 (ALARM IN)	14	DI14 (ALARM IN)
7	DI7 (ALARM IN)	15	DI15 (ALARM IN)
8	DI8 (ALARM IN)	16	DI16 (ALARM IN)

The GND are common ground for the DIs.

If you connect the NVR to a PoE port of the AW-FED series PoE switch, make sure you turn off the PoE output on that specific port using the onboard DIP switch. Otherwise, the high-power output can damage the LAN port on NVR.

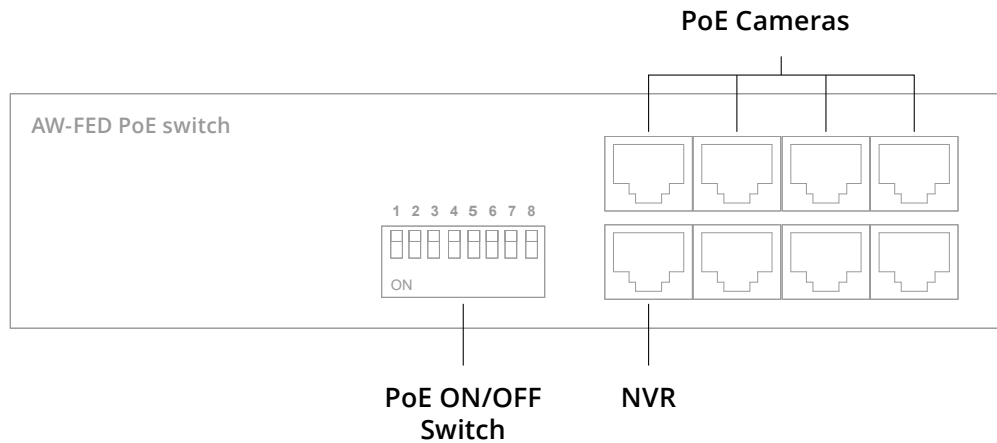

Quick Installation Guide (ND9442P / ND9542P)

Package Contents

- The NVR x1
- QIG x1
- Mouse x1
- Foot Pads x1
- Washer Screw x16
- Flat Head Screws x16
- Terminal Block x4
- Hard Drive Bracket x8
- Power Cable x1
- SATA Data x4
- SATA Power x2

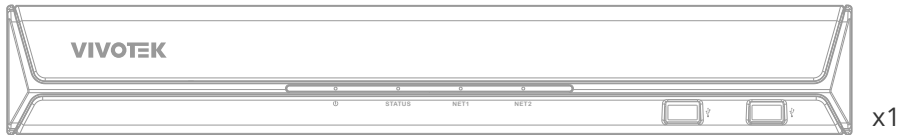

M3 x 6W/SW

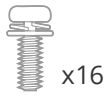

6# x 4

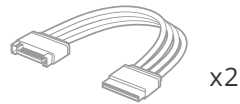
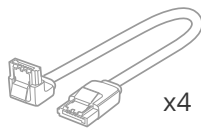
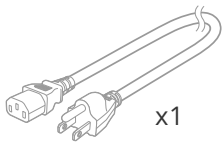

Hardware Installation

SATA hard disk(s) are user-supplied. The network video recorder can readily accommodate most of the off-the-shelf SATA hard drives.

1. Attach 4 foot pads to the bottom of the enclosure.

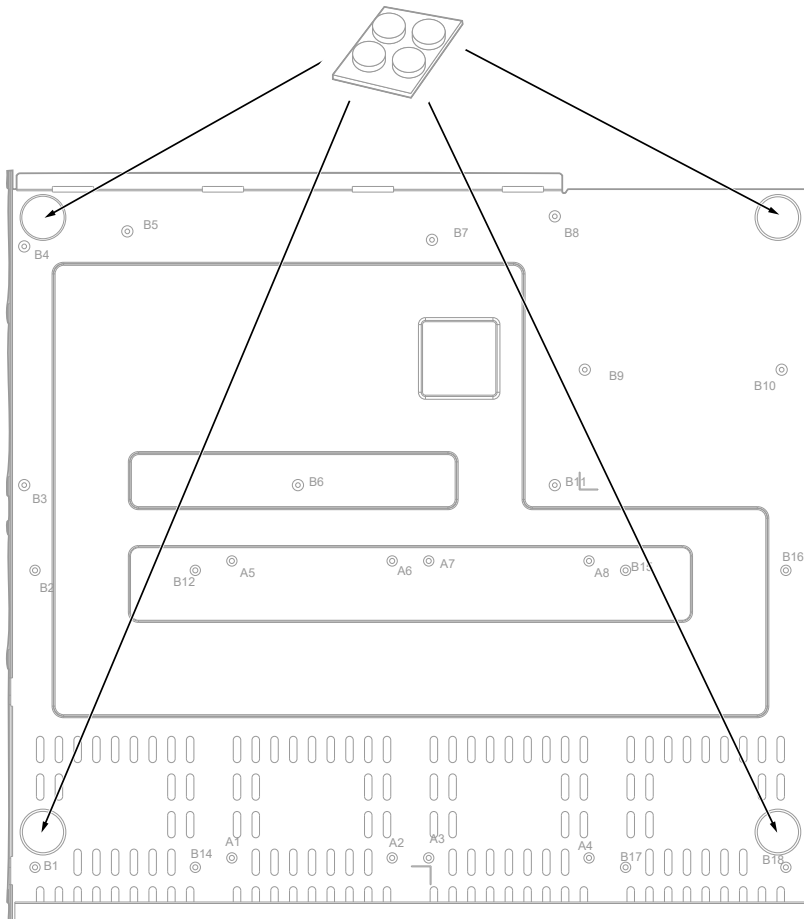

2. Use a Phillips screwdriver to loosen the retention screws on the sides and the back of the chassis. Slide the top cover back, and then remove the top cover.

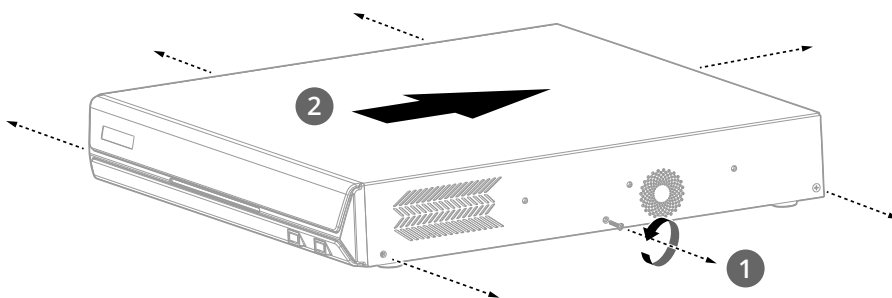

3. Install HDD brackets to the sides of hard disk drives. Note the orientation of the brackets.

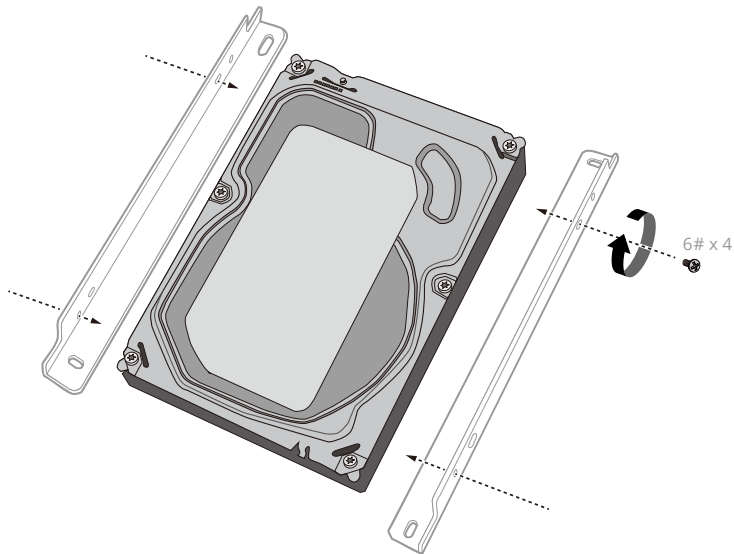

4. The SATA data and power cords are pre-installed.

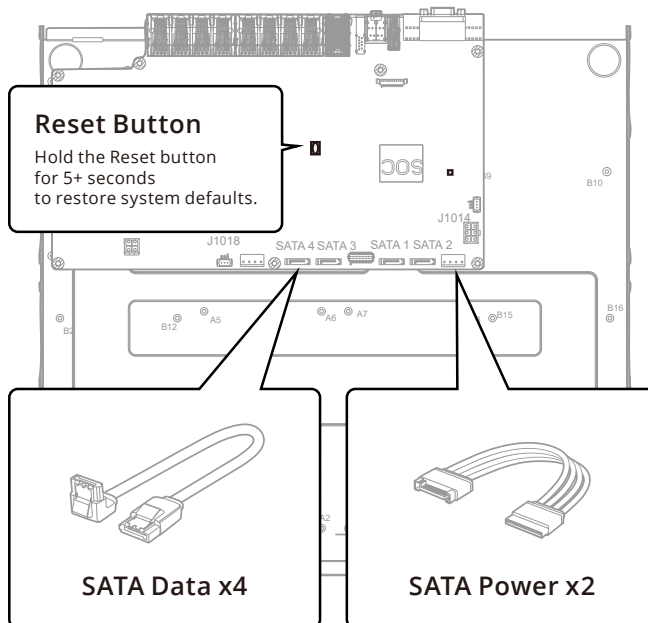

5. Connect the SATA power and SATA data cables to the hard disk drive.

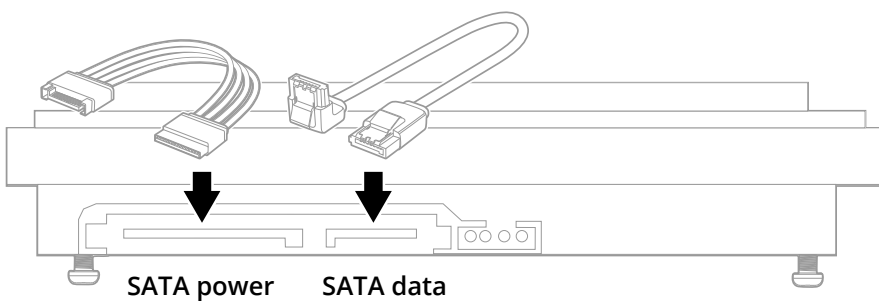

6. Install the hard drive to the chassis. Note that the screws pass through the through holes on the HDD brackets and secure the hard drive to the chassis. When installing hard drives, their label side should be facing up, and the connector side facing the inside of the chassis.

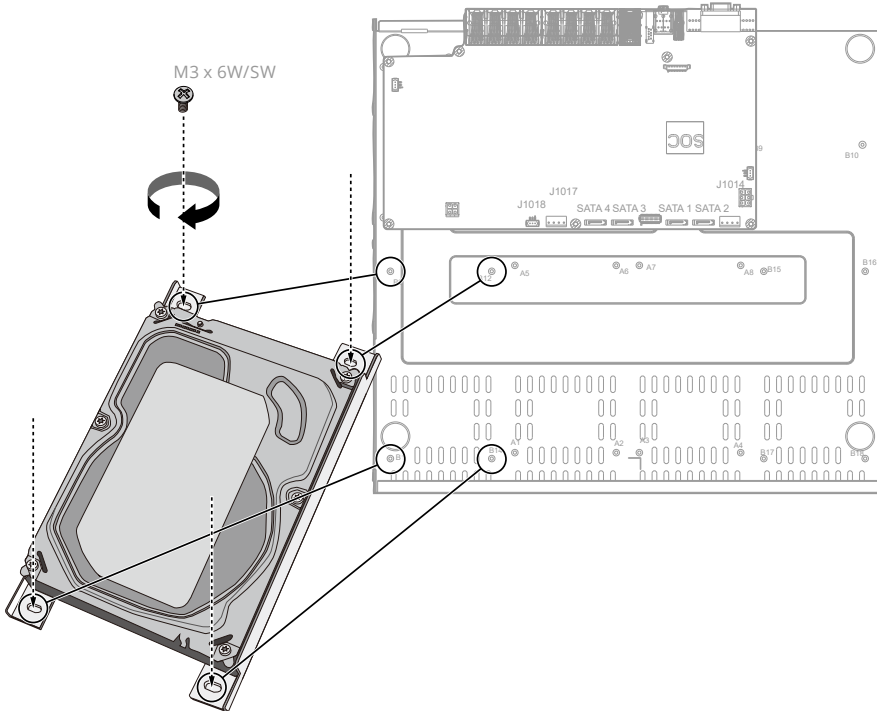

7. The SATA drive numbering order is shown below.

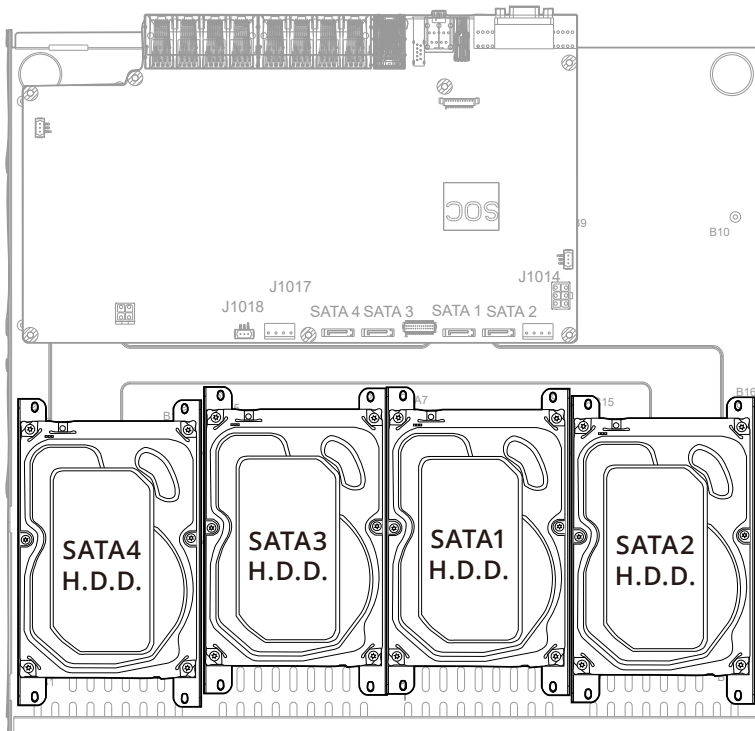

8. When done, install the top cover.

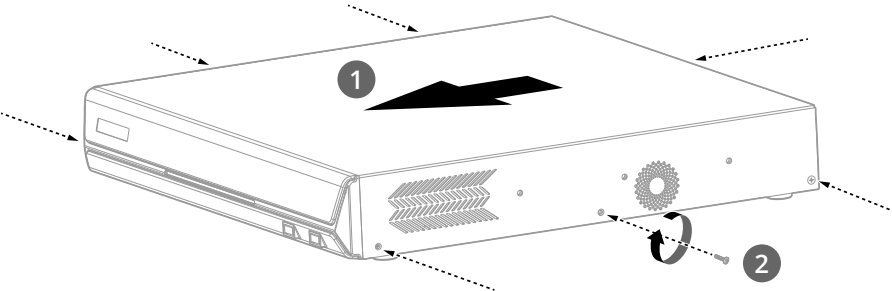

9. Connect a mouse and keyboard to the USB ports at the front.

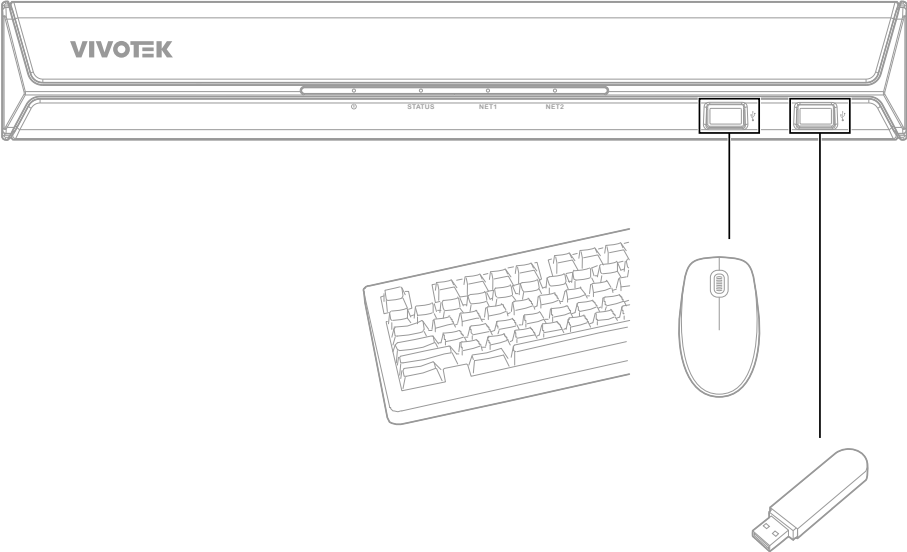

Initial Setup and Configuration

Power on the NVR and follow the on-screen setup wizard to complete the initial configuration.

1

VIVOTEK | ND9442P

• Name & Language
• Password
• Network
• Time
• Cloud service
• Add cameras
• Recording

Name & Language

NVR CORE + AI

Host name

Language

Next

2

VIVOTEK | ND9442P

• Name & Language
• Password
• Network
• Time
• Cloud service
• Add cameras
• Recording

Password

User name

Password

Confirm password

Back Next

3

VIVOTEK | ND9442P

• Name & Language
• Password
• Network
• Time
• Cloud service
• Add cameras
• Recording

Network

Default gateway NET 1 NET 2 (with PoE)

NET 1

IPv4 ^

Configuration

IP

Subnet mask

Gateway

DNS server 1

DNS server 2

IPv6 ^

Link local address

Configuration

IP / Prefix length

Back Next

4

VIVOTEK | ND9442P

- Name & Language
- Password
- Network
- Time**
- Cloud service
- Add cameras
- Recording

Time

Set date and time:

NTP server
 Custom NTP server

Worldwide (pool.ntp.org)

Time zone:

5

VIVOTEK | ND9442P

- Name & Language
- Password
- Network
- Time
- Cloud service**
- Add cameras
- Recording

Cloud service

Card title
 Description text text text text text text
 Loading msg.

Waiting to join the VORTEX organization...

How to activate your VORTEX Connect?
 Step 1 - Download VORTEX app or access portal.
 Step 2 - Add NVR via QR scan or device ID.

QR code: 120x120
 Device ID: **{ID-000-000-000-000-000}**

6

VIVOTEK | ND9442P

- Name & Language
- Password
- Network
- Time
- Cloud service
- Add cameras**
- Recording

Add cameras

Configure factory default VVTK cameras with the NVR password
 Auto stream settings

Found the following online cameras:

VIVOTEK ONVIF

Model	IP	Mac
<input type="checkbox"/> SD9191	192.168.1.12	00-00-00-00-00-00
<input checked="" type="checkbox"/> SD9191	192.168.1.12	00-00-00-00-00-00
<input checked="" type="checkbox"/> SD9191	192.168.1.12	00-00-00-00-00-00
<input type="checkbox"/> SD9191	192.168.1.12	00-00-00-00-00-00
<input type="checkbox"/> SD9191	192.168.1.12	00-00-00-00-00-00

Camera list

Check these cameras in your NVR.

Camera	CH	Status	Mac
<input type="checkbox"/> Camera 01 IP: 1.1.1.1 Model: SD9191	1	Authorized	00-00-00-00-00-00
<input type="checkbox"/> Camera 01 IP: 1.1.1.1 Model: SD9191	2	Unauthorized	00-00-00-00-00-00
<input type="checkbox"/> Camera 01 IP: 1.1.1.1 Model: SD9191	3	Authorized	00-00-00-00-00-00
<input type="checkbox"/> Camera 01 IP: 1.1.1.1 Model: SD9191	4	Authorized	00-00-00-00-00-00

7

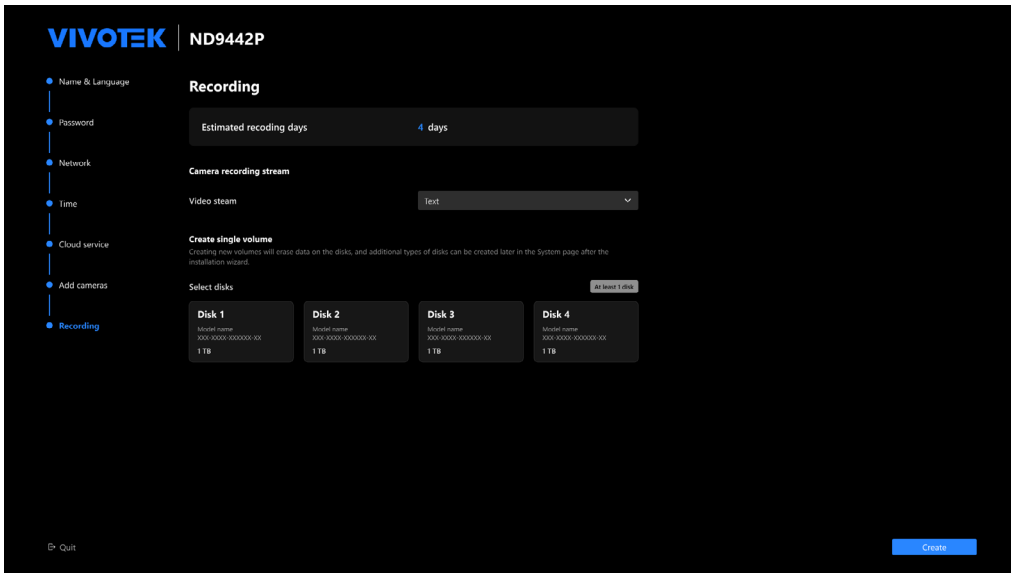

8

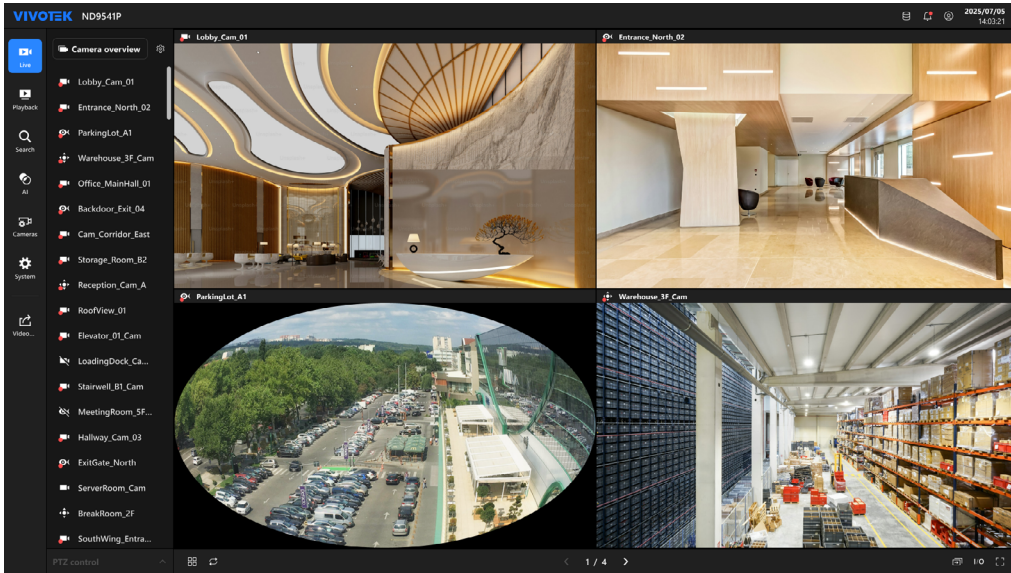

Warnings Before Installation

This section provides pre-installation warnings in multiple languages.

Upozornění před instalací

Čeština

- Produkt je nutné nainstalovat do místa bez snadného přístupu, mimo nárazy či silné vibrace a tak, aby byl chráněný. Může jít například o místo, kde kamery sledují prostředí pod sebou, nebo o vyšší polohu, například sloup, zeď či umístění nejméně 3 metry nad zemí.
- Produkt je potřeba používat v souladu s místními zákony a předpisy.
- Neinstalujte produkt na nestabilním podkladu nebo povrchu.
- Nie demontować kamery ani nie przeprowadzać czynności konserwacyjnych przy włączonym zasilaniu.
- Před instalací by měl být produkt skladován v suchém a větraném prostředí.
- Používejte pouze příslušenství, které odpovídá technickým specifikacím produktu.
- Aby uzyskać informacje o zasilaczach, prosimy o kontakt z autoryzowanymi dealerami VIVOTEK.
- Zajistěte připojení napájecího kabelu do zásuvky s uzemněním nebo ekvivalentní.

Warnung vor der Installation

Deutsch

- Das Produkt muss an einem schwer zugänglichen Ort installiert und geschützt werden, der von Stößen oder starken Vibrationen geschützt ist. Zum Beispiel an dem Ort, an dem die Überwachungskameras nach unten schauen oder in hohen Positionen installiert sind, wie beispielsweise an einem Mast, einer Wand oder mindestens 3 Meter über dem Boden.
- Das Produkt sollte in Übereinstimmung mit den örtlichen Gesetzen und Vorschriften verwendet werden.
- Installieren Sie das Produkt nicht auf einer instabilen Halterung oder Oberfläche.
- Zerlegen Sie die Kamera nicht und führen Sie keine Wartungsarbeiten durch, wenn das Gerät an die Stromversorgung angeschlossen ist.
- Vor der Installation sollte das Produkt in einer trockenen und belüfteten Umgebung gelagert werden.
- Verwenden Sie nur Zubehör, das den technischen Spezifikationen des Produkts entspricht.
- Bitte wenden Sie sich an die zertifizierten Händler von VIVOTEK für Netzteile.
- Stellen Sie sicher, dass das Netzkabel an eine Steckdose mit Erdungsanschluss oder eine gleichwertige Steckdose angeschlossen ist.

Advarsel inden installation

Dansk

- Das Produkt muss an einem schwer zugänglichen Ort installiert und geschützt werden, der von Stößen oder starken Vibrationen geschützt ist. Zum Beispiel an dem Ort, an dem die Überwachungskameras nach unten schauen oder in hohen Positionen installiert sind, wie beispielsweise an einem Mast, einer Wand oder mindestens 3 Meter über dem Boden.
- Das Produkt sollte in Übereinstimmung mit den örtlichen Gesetzen und Vorschriften verwendet werden.
- Installieren Sie das Produkt nicht auf einer instabilen Halterung oder Oberfläche.
- Zerlegen Sie die Kamera nicht und führen Sie keine Wartungsarbeiten durch, wenn das Gerät an die Stromversorgung angeschlossen ist.
- Vor der Installation sollte das Produkt in einer trockenen und belüfteten Umgebung gelagert werden.
- Verwenden Sie nur Zubehör, das den technischen Spezifikationen des Produkts entspricht.
- Bitte wenden Sie sich an die zertifizierten Händler von VIVOTEK für Netzteile.
- Sørg for at tilslutte netledningerne til en stikkontakt med jordforbindelse eller tilsvarende.

Warning Before Installation

English

- Power The product must be installed and protected in a location that is not easily accessible, and is away from impacts or heavy vibration. For example, at the location where the surveillance cameras are looking down or installed at high positions such as on a pole, wall, or at least 3 meters above the ground.
- The product should be used in compliance with local laws and regulations.
- Do not install the product on an unstable mount or surface.

- Do not disassemble the camera or perform maintenance task when power is connected.
- Before installation, the product should be stored in a dry and ventilated environment.
- Use only accessories that comply with the technical specifications of the product.
- Please contact VIVOTEK's certified dealers for power adapters.
- Ensure to connect the power cord to a socket-outlet with earthing connection, or equivalent.

Advertencia antes de la instalación

Español

- El producto debe instalarse y protegerse en un lugar que no sea fácilmente accesible y donde no se someta a impactos o fuertes vibraciones. Por ejemplo, en el lugar donde las cámaras de vigilancia miran hacia abajo o se instalan en posiciones altas, como en un poste, una pared o al menos 3 metros sobre el suelo.
- El producto debe usarse de acuerdo con las leyes y regulaciones locales.
- No instale el producto en un estante o soporte inestables.
- No desmonte la cámara ni realice tareas de mantenimiento cuando esté conectada la alimentación.
- Antes de la instalación, el producto debe almacenarse en un entorno seco y ventilado.
- Use solo accesorios que cumplan con las especificaciones técnicas del producto.
- Póngase en contacto con los distribuidores certificados de VIVOTEK para los adaptadores de corriente.
- Asegúrese de conectar el cable de alimentación a una toma de corriente con conexión a tierra o equivalente.

Avertissement avant installation

Français

- Le produit doit être installé et protégé dans un endroit difficilement accessible, à l'abri des chocs et des vibrations importantes. Par exemple, à l'endroit où les caméras de surveillance sont dirigées vers le bas ou installées à des endroits élevés, par exemple sur un poteau, un mur ou au moins à 3 mètres du sol.
- Le produit doit être utilisé conformément aux lois et réglementations locales.
- Ne pas installer le produit sur un support ou une surface instable.
- Ne démontez pas la caméra et n'effectuez pas de travaux de maintenance lorsque celle-ci est sous tension.
- Avant l'installation, le produit doit être entreposé dans un endroit sec et ventilé.
- N'utiliser que des accessoires conformes aux spécifications techniques du produit.
- Veuillez contacter les revendeurs certifiés VIVOTEK pour les adaptateurs d'alimentation.
- Assurez-vous de brancher le cordon d'alimentation à une prise de courant avec connexion à la terre, ou équivalent.

Avvertenza prima dell'installazione

Italiano

- Il prodotto deve essere installato e protetto in un luogo non facilmente accessibile e lontano da urti o forti vibrazioni. Ad esempio, nel luogo in cui le telecamere di sorveglianza guardano verso il basso o sono installate in posizioni elevate, ad esempio su un palo, un muro o almeno 3 metri dal suolo.
- Il prodotto deve essere utilizzato in conformità con le leggi e i regolamenti locali.
- Non installare il prodotto su un supporto o una superficie instabili.
- Non smontare la fotocamera o eseguire attività di manutenzione quando l'alimentazione è collegata.
- Prima dell'installazione, il prodotto deve essere conservato in un ambiente asciutto e ventilato.
- Utilizzare solo accessori conformi alle specifiche tecniche del prodotto.
- Si prega di contattare i rivenditori certificati di VIVOTEK per adattatori di alimentazione.
- Assicurarsi di collegare il cavo di alimentazione ad una presa dotata di collegamento a terra o equivalente.

インストール前の注意

日本語

- 本製品は手が届きにくく、衝撃や大きな振動のない場所に設置し、保護する必要があります。例えば、監視カメラが見下ろす場所、またはポールの上や壁、床面から3メートル以上の高い位置に設置します。
- 本製品は地域の法律及び規則に従って使用してください。
- 不安定な取付具または表面上に製品を設置しないでください。
- カメラを分解したり、電源が接続されているときにメンテナンスをしたりしないでください。

- セキュリティ基準 (新規則第 34 条の 10): 「本製品は 電気通信事業者 (移动通信会社、固定通信会社、インターネットプロバイダ等) の通信回線 (公衆無線 LAN を含む) に直接接続することができません。本製品をインターネットに接続する場合は、必ずルータ等を經由し接続してください。」
- 設置する前、本製品は乾燥した通気の良い環境に保管してください。
- 本製品の技術仕様に準拠した付属品のみを使用してください。
- 電源アダプタについては VIVOTEK の認定販売店にお問い合わせください。
- 電源が接地された電源コンセントに接続されていることを確認してください。

Peringatan Sebelum Pemasangan

Bahasa Melayu

- Produk harus dipasang dan dilindungi di lokasi yang tidak mudah dijangkau, serta jauh dari benturan atau getaran hebat. Misalnya, di lokasi di mana kamera pengawasan mengarah ke bawah atau dipasang di posisi tinggi seperti di atas tiang, tembok, atau minimal 3 meter di atas tanah.
- Produk harus digunakan sesuai dengan undang-undang dan aturan setempat.
- Jangan memasang produk di atas dudukan atau permukaan yang tidak stabil.
- Jangan membongkar kamera atau melakukan kerja perawatan dalam kondisi daya terhubung.
- Sebelum pemasangan, produk harus disimpan di lingkungan yang kering dan berventilasi.
- Gunakan hanya aksesori yang sesuai dengan spesifikasi teknis produk.
- Silakan hubungi dealer bersertifikat VIVOTEK untuk adapter daya.
- Pastikan untuk menyambungkan kabel daya ke stopkontak dengan sambungan pembumian, atau yang setara.

Waarschuwing voor installatie

Nederlands

- Dit product moet worden geïnstalleerd en beschermd op een plek die niet makkelijk toegankelijk is en niet blootgesteld is aan schokken en trillingen. Bijvoorbeeld, op de plek waar de bewakingscamera's naar beneden staan gericht of zijn geïnstalleerd op hoge posities zoals op een paal, een muur of tenminste 3 meter boven de grond.
- Het product dient te worden gebruikt conform lokale wetgeving en regelgeving.
- Installeer het product niet op een onstabiele standaard of oppervlak.
- Demonteer de camera niet en pleeg geen onderhoud terwijl de stroom is aangesloten.
- Het product moet voor de installatie worden opgeborgen in een droge en geventileerde omgeving.
- Gebruik alleen accessoires die voldoen aan de technische specificaties van het product.
- Neem contact op met gecertificeerde VIVOTEK dealers voor stroomadapters.
- Zorg ervoor dat u het netsnoer aansluit op een stopcontact met aardaansluiting, of gelijkwaardig.

Zalecenia dotyczące bezpieczeństwa

Polski

- Produkt należy zainstalować i zabezpieczyć w miejscu, które nie jest łatwo dostępne i nie jest narażone na silne wstrząsy lub wibracje. Na przykład w miejscu, w którym kamery monitoringu są skierowane w dół lub są zainstalowane na wysokości na słupie, ścianie lub przynajmniej 3 metry powyżej podłoża.
- Produkt należy używać zgodnie z lokalnymi przepisami.
- Nie instalować produktu na niestabilnych mocowaniach lub powierzchniach.
- Nerozebírejte kameru ani neprovádějte její údržbu, pokud je připojená k napájení.
- Produkt przed instalacją należy przechowywać w suchym i dobrze wentylowanym środowisku.
- Używać wyłącznie akcesoriów spełniających specyfikacje techniczne produktu.
- Síťové adaptéry lze získat u certifikovaných prodejců společnosti VIVOTEK.
- Upewnij się, że przewód zasilający jest podłączony do gniazdka elektrycznego z uziemieniem lub równoważnego.

Aviso antes da instalação

Português

- O produto deve ser instalado e protegido em um local que não seja facilmente acessível, e estar longe de impactos ou vibrações fortes. Por exemplo, no local onde as câmeras de vigilância estão olhando para baixo ou instaladas em altas posições como em um poste, parede, ou, pelo menos, 3 metros acima do solo.
- O produto deve ser utilizado em conformidade com as leis e regulamentos locais.

- Não instale o produto em uma montagem ou superfície instável.
- Não desmonte a câmera ou execute tarefas de manutenção quando a alimentação estiver ligada.
- Antes da instalação, o produto deve ser armazenado em local seco e ventilado.
- Utilize apenas acessórios que estejam em conformidade com as especificações técnicas do produto.
- Favor entrar em contato com revendedores certificados da VIVOTEK sobre adaptadores de corrente.
- Certifique-se de conectar o cabo de alimentação a uma tomada conectada à terra ou equivalente.

Перед установкой

Русский

- Это изделие следует устанавливать в защищенном, труднодоступном месте, обеспечивающем защиту от воздействия ударов и сильных вибраций. Например, следует устанавливать камеры наблюдения на большой высоте не менее 3 метров над землей — на столбе или стене, так чтобы камеры были направлены вниз.
- Эксплуатация изделия должна осуществляться в соответствии с местными законами и нормами.
- Не устанавливайте это изделие на неустойчивых креплениях или поверхностях.
- Не разбирайте камеру и не выполняйте процедуры по ее техническому обслуживанию при подключенном питании.
- До установки это изделие следует хранить в сухом, хорошо проветриваемом месте.
- Используйте только принадлежности, отвечающие техническим характеристикам изделия.
- Используйте только принадлежности, отвечающие техническим характеристикам изделия.
- Обязательно подключите шнур питания к розетке с заземлением или к эквивалентной розетке.

العربية

تحذير قبل التثبيت

- يجب تثبيت المنتج وحمايته في موقع لا يمكن الوصول إليه بسهولة، ويكون بعيداً عن التأثيرات أو الاهتزازات الشديدة. على سبيل المثال، في موقع حيث تنظر كاميرات المراقبة إلى أسفل أو تم تثبيتها في مواقع عالية على سبيل المثال، على عمود أو جدار أو على الأقل 3 أمتار فوق الأرض.
- يجب استخدام المنتج وفقاً للقوانين واللوائح المحلية.
- لا تقم بتثبيت المنتج على حامل أو سطح غير مستقر.
- لا تقم بفك الكاميرا أو تجر مهمة الصيانة أثناء توصيل الطاقة.
- قبل التثبيت، يجب أن يتم تخزين المنتج في بيئة جافة وجيدة التهوية.
- استخدم فقط الملحقات التي تتوافق مع المواصفات الفنية للمنتج.
- يُرجى الاتصال بتجار VIVOTEK المعتمدين لمهايئات الطاقة.
- تأكد من توصيل سلك الطاقة بمنفذ مقبس مزود بوصلة أرضية أو ما يعادله.

安装警告

简体中文

- 本产品必须安装在不易接近的地点，妥善保护，避免受到冲击或强烈振动。例如，安装在可让监控摄像头保持俯视的地点或较高位置，如支柱、墙壁或距地面至少 3 米的位置。
- 应依当地法律法规使用本产品。
- 请勿将本产品安装在不平稳的支架或平面上。
- 切勿在接通电源的情况下拆卸摄像头或进行维护。
- 安装前，应将本产品存放在干燥、通风的环境下。
- 仅使用符合本产品技术规格的配件。
- 如需电源适配器，请联系 VIVOTEK 认证经销商。
- 确保电源是连接于有接地的电源插座。

Varning innan installation

Svenska

- Produkten måste installeras och skyddas på en plats som inte är lättillgänglig, där den inte utsätts för stötar och kraftiga vibrationer. Till exempel på en plats där övervakningskamerorna tittar ner eller installeras på höga positioner som på en stolpe, en vägg eller minst 3 meter ovanför marken.
- Produkten ska användas i enlighet med lokala lagar och föreskrifter.
- Installera inte produkten på ett instabilt stativ eller en instabil yta.
- Plocka inte isär kameran eller utför inget underhåll när strömmen är ansluten.

- Innan installation ska produkten förvaras i en torr och ventilerad miljö.
- Använd endast tillbehör som överensstämmer med produktens tekniska specifikationer.
- Kontakta VIVOTEKs certifierade återförsäljare för nätadapterar.
- Se till att ansluta nätsladden till ett uttag med jordad anslutning eller motsvarande.

安裝前應注意事項

繁體中文

- 本產品必須安裝並放置在不容易拿取的位置，且必須遠離衝擊或劇烈震動。例如，請安裝在讓監視攝影機能朝下監看的位置，或安裝在電線杆、牆壁或離地至少 3 公尺的高處。
- 本產品之使用必須符合當地的法律與規定。
- 請勿將產品安裝在不平穩的支架或平面上。
- 請勿在連接電源的情況下拆解攝影機或執行維護工作。
- 在安裝本產品前，請將產品存放在乾燥且通風的環境。
- 僅使用符合本產品技術規格的配件。
- 如需電源供應器，請聯繫 VIVOTEK 認證經銷商。
- 確保電源是連接於有接地的電源插座。

Kurulum Öncesi Uyarılar

Türkçe

- Ürün kolayca erişilemeyen ve darbe veya ağır titreşimden uzakta bir yere kurulmalı ve korunmalıdır. Örneğin, güvenlik kameralarının aşağıya baktığı veya direk, duvar gibi yüksek pozisyonlara veya yerden en az 3 metre yükseğe kurulduğu yerler.
- Ürün, yerel yasa ve yönetmeliklerle uyumlu kullanılmalıdır.
- Ürünü, dengesiz bir yere veya yüzeye kurmayın.
- Güç bağlandığında kamerayı sökmeyin veya bakım işi yapmayın.
- Kurulumdan önce, ürün kuru ve havalandırılmış bir ortamda saklanmalıdır.
- Yalnızca ürünün teknik özelliklerine uygun aksesuarları kullanın.
- Güç adaptörleri için VIVOTEK'in yetkili bayileriyle temasa geçin.
- Güç kablosunu topraklama bağlantısı veya eşdeğeri olan bir prize bağladığınızdan emin olun.

設備名稱：網路影像錄影機 Equipment name: Network Video Recorder		型號 (型式): ND9442P, ND9542P Type designation (Type): ND9442P, ND9542P				
單元 Unit	限用物質及其化學符號 Restricted substances and its chemical symbols					
	鉛 (Pb)	汞 (Hg)	鎘 (Cd)	六價鉻 (Cr ⁺⁶)	多溴聯苯 (PBB)	多溴二苯醚 (PBDE)
塑膠組件	○	○	○	○	○	○
電路板組件	○	○	○	○	○	○
線材組件	○	○	○	○	○	○
螺絲組件	○	○	○	○	○	○
備考 1. "超出 0.1wt%" 及 "超出 0.01wt%" 係指限用物質之百分比含量超出百分比含量基準值。 Note 1: "Exceeding 0.1 wt%" and "exceeding 0.01 wt%" indicate that the percentage content of the restricted substance exceeds the reference percentage value of presence condition. 備考 2. "○" 係指該項限用物質之百分比含量未超出百分比含量基準值。 Note 2: "○" indicates that the percentage content of the restricted substance does not exceed the percentage of reference value of presence. 備考 3. "—" 係指該項限用物質為排除項目。 Note 3: "—" indicates that the restricted substance corresponds to the exemption.						
最大消耗功率 Max. power consumption		---				
運作溫度 Operating temperature		---				

重要安全規範及資訊： 您國家的法律可能會禁止使用監控裝置。此效能優異的網路攝影機不僅隨時能夠連接網路，更能應用於具有彈性的監視系統，使用者安裝本產品前，必須確保其預期操作用途完全合法。首先請確認所取得的產品完整無誤。請先注意「快速安裝指南」內的警告，再安裝本網路攝影機；並確實遵守指示，避免組裝及安裝錯誤，造成產品損壞，如此亦能確保本產品受到妥善運用。

宣告甲類 /Class A CNS 15936 警語： 為避免電磁干擾，本產品不應安裝或使用於住宅環境。

警告： 1. 如果使用電源轉接器供電，此轉接器應正確接地。 2. 安裝和維護服務只能由合格的技术人員進行。 3. 執行維護任務時，請中斷設備電源。 4. 請只使用經過 UL 認證的直流電源和有限的電源，來使用攝影機。 5. LPS 認證。電源供應器應附有 UL 認證和 LPS 標誌。 6. 電源供應也應滿足使用國家 / 地區的任何安全和規範要求。 7. 攝影機安裝位置應距離建築物屋簷至少 10 公分。 8. 產品應安裝在建築物屋簷下，並避免外部電線直接暴露在陽光和水環境中。 9. 電源線必須連接至有接地線的插座。 10. 攝影機只能連接到 PoE 網絡，不能路由到外部設備。 11. 如須購買電源供應器，請聯絡 VIVOTEK 認證經銷商或代理商。 12. 使用 RTC battery 需加註電池警語如下： a. 若置換不同型式之電池有起火或爆炸風險。 b. 如果更換後的電池型式不正確，會有爆炸的風險。並請根據指示，處理廢棄電池。 c. 請根據指示丟棄使用過的電池。 13. 注意壁掛螺絲直徑及長度。

UL Warning: 1. If powered by a power adapter, the adapter should be properly grounded. 2. Installation and maintenance service should only be performed by qualified technicians. 3. Disconnect power from the unit when performing a maintenance task. 4. Use the camera only with a DC power supply that is UL listed, and limited power source (LPS) certified. The power supply should bear the UL listed and LPS marks. The power supply should also meet any safety and compliance requirements for the country of use. 5. The camera is only to be connected to PoE networks without routing to outside plants. 6. For PoE connection, use only UL listed I.T.E with PoE output. Please contact VIVOTEK's certified dealers for power adapters. 7. Ground wire to the grounding position: a. The minimum ground screw type is 3.5mm. b. The minimum wire gauge is 18AWG: b-1. Use green/yellow (green with yellow stripe) ground wires. b-2. Use a knurled washer for securing the grounding screw. 8. The camera should be installed at least 10 centimeters away from the eave of a building. The product will be installed under the eaves of the building, and will avoid direct exposure of the external wire to the sun and water environment.

CAUTION: RISK OF EXPLOSION IF BATTERY IS REPLACED BY AN INCORRECT TYPE. DISPOSE OF USED BATTERIES ACCORDING TO THE INSTRUCTIONS.

The equipment comes with a RTC battery. Note the following: 1. Replacement of a battery with an incorrect type that can defeat a safeguard (for example, in the case of some lithium battery types). 2. Disposal of a battery into fire or a hot oven, or mechanically crushing or cutting of a battery, that can result in an explosion. 3. Leaving a battery in an extremely high temperature surrounding environment that can result in an explosion or the leakage of flammable liquid or gas. 4. A battery subjected to extremely low air pressure that may result in an explosion or the leakage of flammable liquid or gas. 5. disposal of a battery into fire or a hot oven, or mechanically crushing or cutting of a battery, that can result in an explosion.

Please contact authorized distributors for warranty and RMA service.

Warranty www.vivotek.com/support/warranty

RMA www.vivotek.com/support/rma

AM-612 Rack Mount Rail Installation

Before Installation, you should know:

- Confirm the installation cabinet depth.
- AM-612 is only suitable for 50-70 cm rack depth.

Front



Rear



After installation

In this example, the two brackets stretch for 50 cm.



Installation steps

1. Pull out the front end from the AM-612 blocking point.



2. Install the AM-612 front and rear ears, and use M4 black screws to hold the front and rear brackets.



3. After setting the length of AM-612 to the same depth as the locking depth of the rack, tighten the black screws on the brackets to fix the length of the brackets. Then, lock AM-612 into the cabinet.

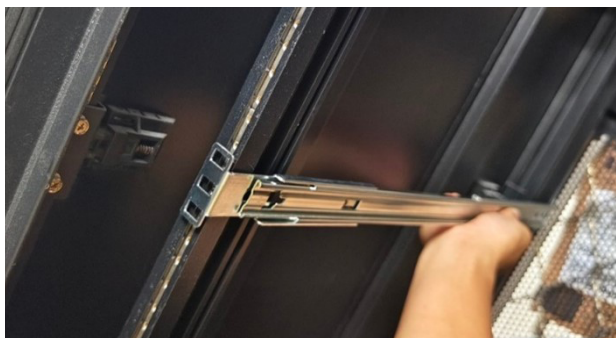

4. Install the front end bracket of AM-612 and lock it to the NVR. The blocking point must be inside the NVR.



5. Assemble the NVR (with the installed front bracket) and the rear bracket on the rack.

B Physical Overview (ND9326P / ND9426P)

Chassis Dimensions

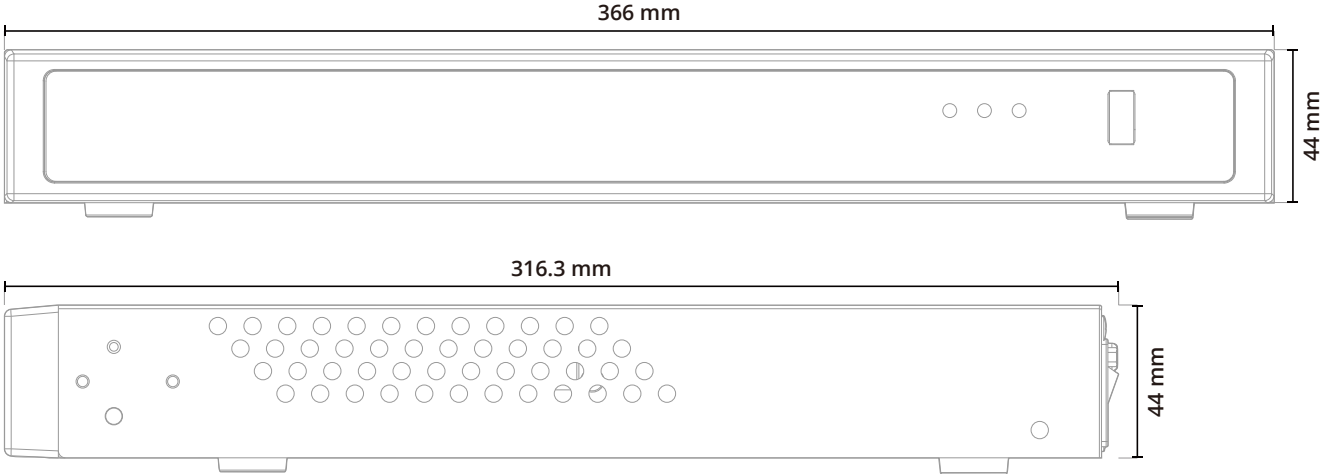

Front View



- 1 Network uplink status/activity LED
- 2 System status LED
- 3 System power status
- 4 USB 3.0 port

LED Indicators

No.	Name	Behavior	Definitions
1	NET LED	Blinking (Green)	Data is being transmitted or received.
		OFF	The Ethernet uplink NET1 or NET2 is disconnected.
2	Status LED	Constant (Green)	System ready.
		Blinking (Green) every 1 second	Updating firmware or device pack.
		Constant (Red)	1. S.M.A.R.T.-related disk errors. 2. A configured H.D.D. is missing. 3. H.D.D. is full. Buzzer will also be sounded. When buzzer is turned off, LED will return normal.
3	Power LED	Solid (Green)	The NVR is powered on.
		OFF	The NVR is powered off.

Rear View

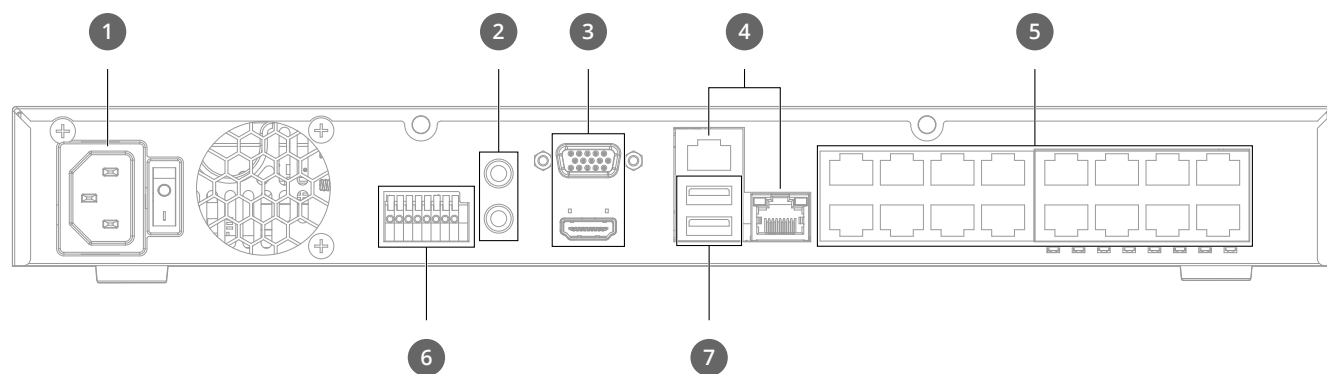

- 1 AC100~240V 50/60Hz
- 2 Audio IN/OUT
- 3 VGA/HDMI
- 4 RJ45 Port
- 5 #1~16 PoE Ports
- 6 DI/DO
- 7 USB 2.0

- Connect to a monitor using an HDMI cable. VGA is also supported.
- Connect CAT5e or better-quality Ethernet cable to the GbE Ethernet port.
- Connect USB devices such as, mouse, keyboard, USB optical drive, or USB thumb drive (formatted in FAT format), or joystick.
- Connect external devices, such as sensors, relays, or alarms to the terminal block.

- Connect the system to the power supply.
- PoE ports are in the same network domain as NET 2.
- If you connect external USB storage, connect it to the USB 3.0 port (at the back of the chassis).

Please do not connect the NVR's PoE ports to non-PD* devices (such as an Ethernet switch LAN port). The Ethernet control circuits may not be compatible.

* PD = A Powered Device designed to receive power source from a PoE connection such as network cameras.

Terminal Block Connections

The terminal block pinouts are shown as follows:

The relay pins default status is set to Normally Open. Connect your relay or external devices' signal wires to the system, the system will automatically detect the current signal status. You can then trigger the external devices using the DI/DO panel on the live view.

You can also configure the system alarm setting for the system to automatically trigger a relay pin on the occurrence of system events.

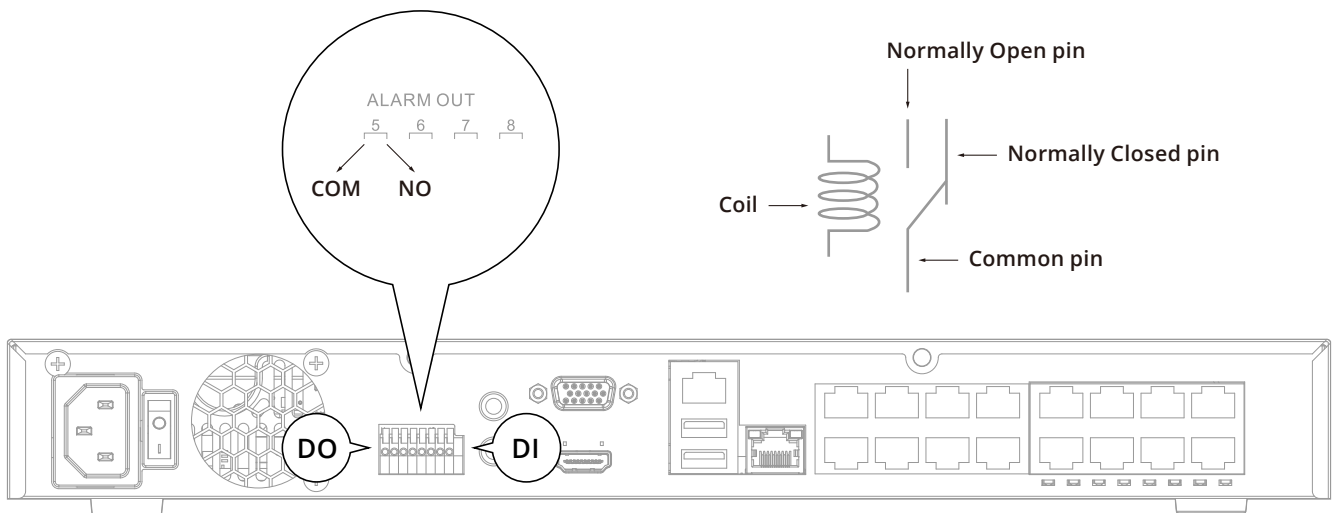

DO

1	NO1	5	NO5	RS485	Data+
	COM1		COM5		RS485
2	NO2	6	NO6		
	COM2		COM6		
3	NO3	7	NO7		
	COM3		COM7		
4	NO4	8	NO8		
	COM4		COM8		

A 120Ω terminator is enabled on the bus. The terminator cannot be disabled.

DI

G	Pins #1~8 share a common ground.	G	Pins #9~16 share a common ground.
G		G	
1	DI1 (ALARM IN)	9	DI9 (ALARM IN)
2	DI2 (ALARM IN)	10	DI10 (ALARM IN)
3	DI3 (ALARM IN)	11	DI11 (ALARM IN)
4	DI4 (ALARM IN)	12	DI12 (ALARM IN)
5	DI5 (ALARM IN)	13	DI13 (ALARM IN)
6	DI6 (ALARM IN)	14	DI14 (ALARM IN)
7	DI7 (ALARM IN)	15	DI15 (ALARM IN)
8	DI8 (ALARM IN)	16	DI16 (ALARM IN)

The GND are common ground for the DIs.

If you connect the NVR to a PoE port of the AW-FED series PoE switch, make sure you turn off the PoE output on that specific port using the onboard DIP switch. Otherwise, the high-power output can damage the LAN port on NVR.

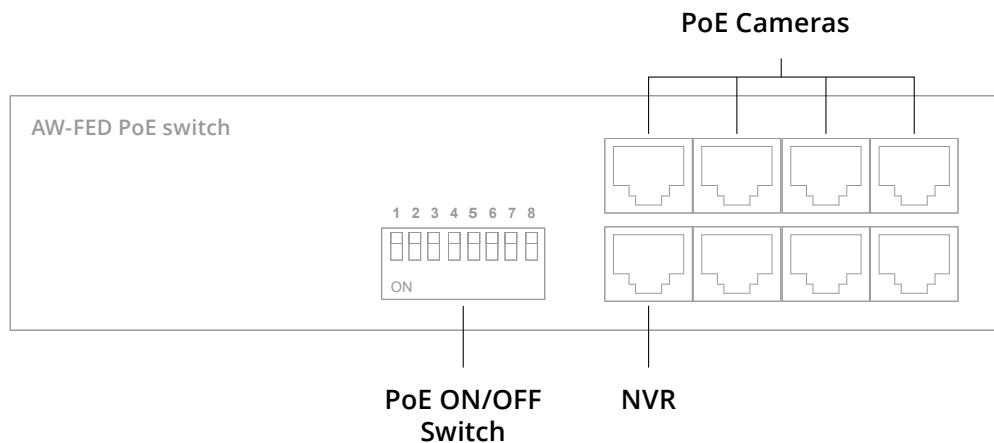

Quick Installation Guide (ND9326P / ND9426P)

Package Contents

- The NVR x1
- QIG x1
- Mouse x1
- Foot Pads x1
- P Head Screw x12
- L-bracket x2
- Power Cable x1
- SATA Data x4
- SATA Power x2

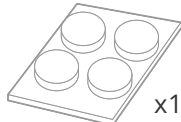
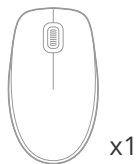

Screws x8

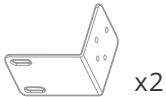

P head 6#-32 x4

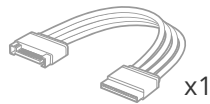
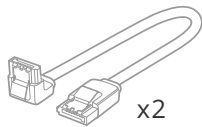
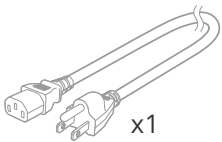

Hardware Installation

SATA hard disk(s) are user-supplied. The network video recorder can readily accommodate most of the off-the-shelf SATA hard drives.

1. Attach 4 foot pads to the bottom of the enclosure.

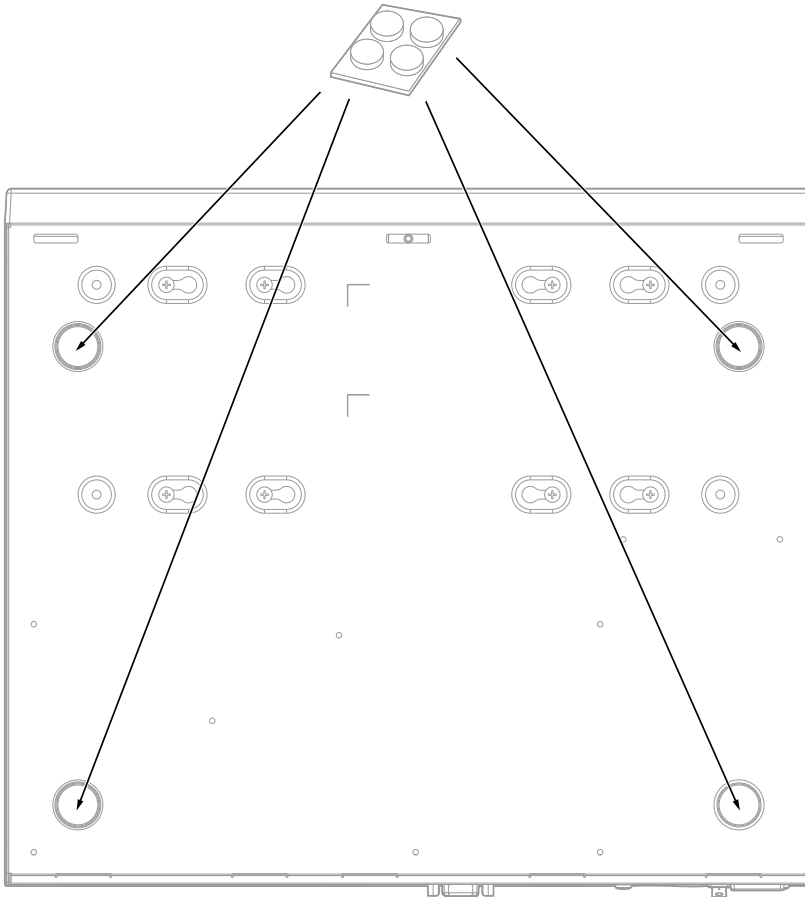

2. Use a screwdriver to loosen the retention screws on the sides and the back of the chassis. Slide the top cover back, and then remove the top cover.

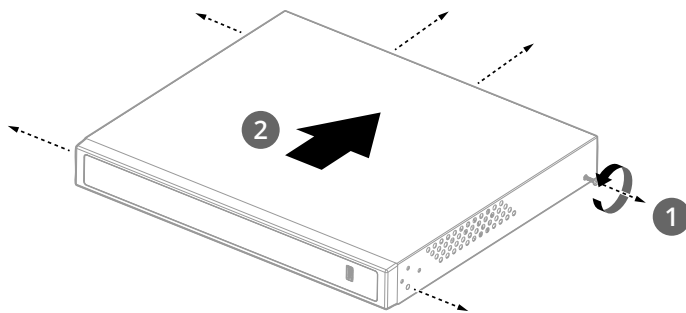

3. Connect SATA data and power cables to the main board.

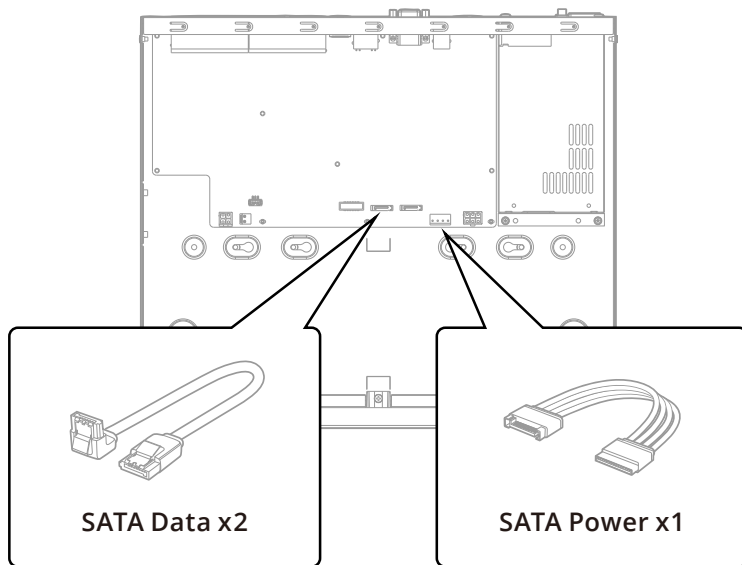

4. Connect the SATA power and SATA data cables to the hard disk drives.

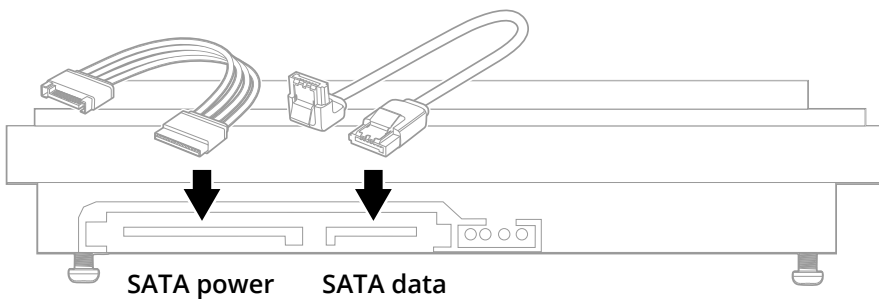

5. Install the hard drives label-side up, connectors facing inward. Secure them from the chassis bottom using the drives underside mounting holes.

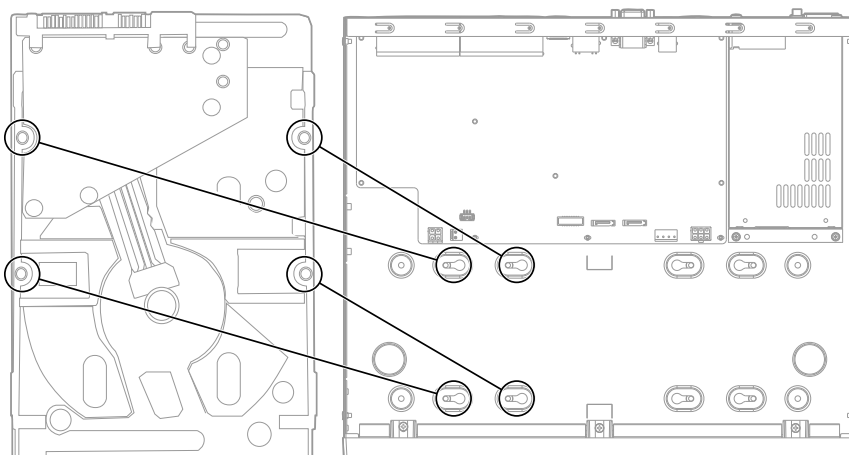

6. Partially fasten screws to the drives, align screw heads with the key slots, then fully tighten from the chassis bottom.

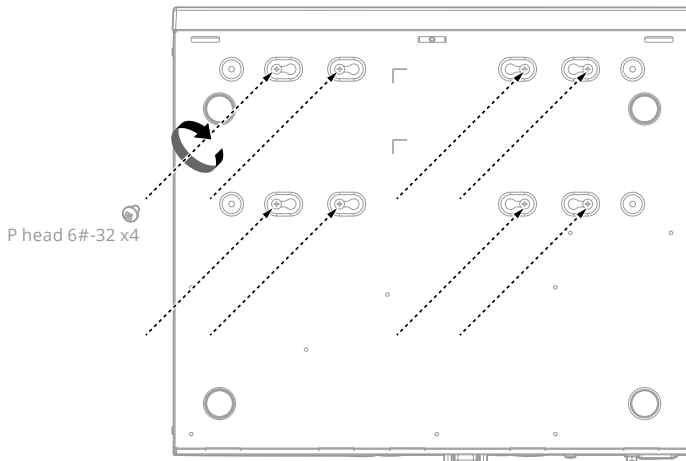

7. Secure the hard disks in the chassis label-side up, connectors inward, as shown below.

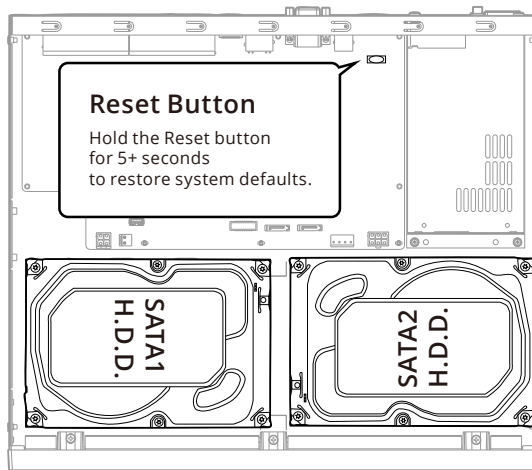

8. Secure the hard disks in the chassis label-side up, connectors inward, as shown below.

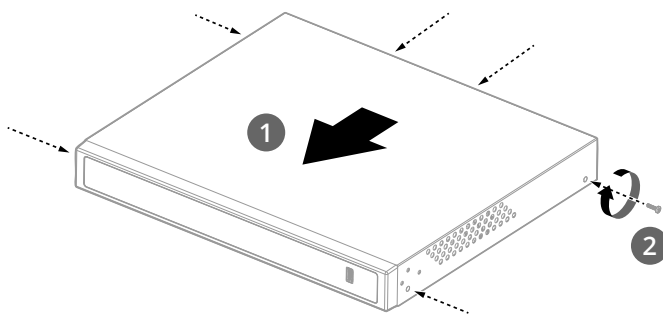

9. If you need to install the NVR system into a rack cabinet:

- 1** Secure the brackets to the sides of the chassis by driving 3 included screws.

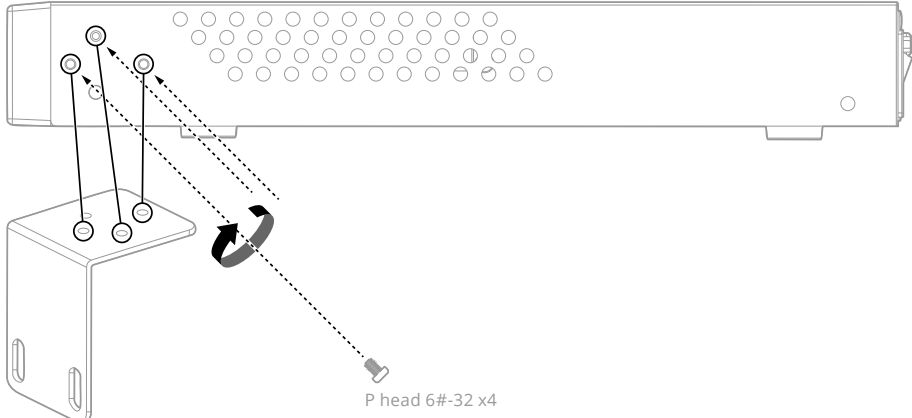

- 2** Secure the chassis to rack posts using 2 M6 screws on each side.



10. Connect a mouse and keyboard to the USB ports at the front.

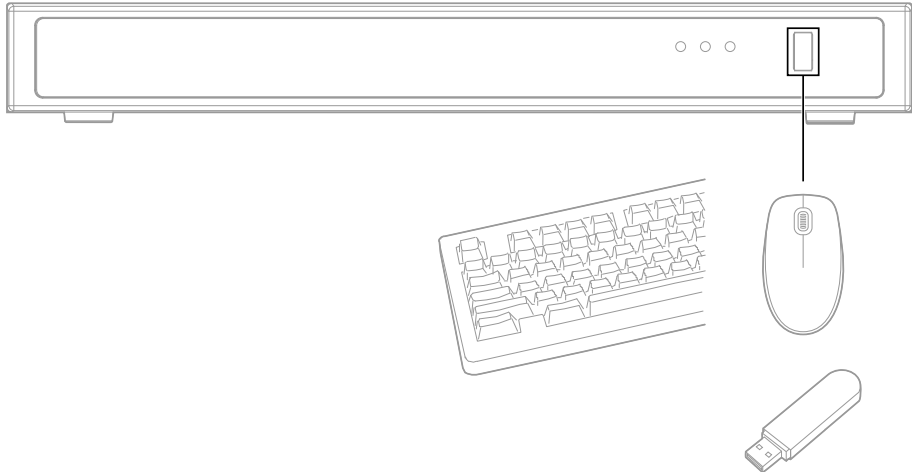

Initial Setup and Configuration

Power on the NVR and follow the on-screen setup wizard to complete the initial configuration.

1

VIVOTEK | ND9442P

- Name & Language
- Password
- Network
- Time
- Cloud service
- Add cameras
- Recording

Name & Language

NVR CORE + AI

Host name

Language

Next

2

VIVOTEK | ND9442P

- Name & Language
- Password
- Network
- Time
- Cloud service
- Add cameras
- Recording

Password

User name

Password

Confirm password

Back Next

3

VIVOTEK | ND9442P

- Name & Language
- Password
- Network
- Time
- Cloud service
- Add cameras
- Recording

Network

Default gateway NET 1 NET 2 (with PoE)

NET 1

IPv4 ^

Configuration

IP

Subnet mask

Gateway

DNS server 1

DNS server 2

IPv6 ^

Link local address

Configuration

IP / Prefix length

Back Next

4

5

6

7

VIVOTEK ND9442P

- Name & Language
- Password
- Network
- Time
- Cloud service
- Add camera
- **Recording**

Recording

Estimated recording days: 4 days

Camera recording stream

Video stream: Text

Create single volume
Creating from volumes will erase data on the disks, and additional types of disks can be created later in the System page after the installation wizard.

Select disks

Disk 1	Disk 2	Disk 3	Disk 4
Model name: XXX-XXXX-XXXXXXXX-XX 1 TB	Model name: XXX-XXXX-XXXXXXXX-XX 1 TB	Model name: XXX-XXXX-XXXXXXXX-XX 1 TB	Model name: XXX-XXXX-XXXXXXXX-XX 1 TB

Get Next Step

Quit Create

8

VIVOTEK ND9541P

2024/07/09 14:03:21

Camera overview

- Lobby_Cam_01
- Entrance_North_02
- ParkingLot_A1
- Warehouse_3F_Cam
- Office_MainHall_01
- Backdoor_Exit_04
- Cam_Corridor_East
- Storage_Room_B2
- Reception_Cam_A
- RoofView_01
- Elevator_01_Cam
- LoadingDock_Ca...
- Stairwell_B1_Cam
- MeetingRoom_SF...
- Hallway_Cam_03
- ExitGate_North
- ServerRoom_Cam
- BreakRoom_2F
- SouthWing_Entra...

PTZ control

1 / 4

Warnings Before Installation

This section provides pre-installation warnings in multiple languages.

Upozornění před instalací

Čeština

- Produkt je nutné nainstalovat do místa bez snadného přístupu, mimo nárazy či silné vibrace a tak, aby byl chráněný. Může jít například o místo, kde kamery sledují prostředí pod sebou, nebo o vyšší polohu, například sloup, zeď či umístění nejméně 3 metry nad zemí.
- Produkt je potřeba používat v souladu s místními zákony a předpisy.
- Neinstalujte produkt na nestabilním podkladu nebo povrchu.
- Nie demontować kamery ani nie przeprowadzać czynności konserwacyjnych przy włączonym zasilaniu.
- Před instalací by měl být produkt skladován v suchém a větraném prostředí.
- Používejte pouze příslušenství, které odpovídá technickým specifikacím produktu.
- Aby uzyskać informacje o zasilaczach, prosimy o kontakt z autoryzowanymi dealerami VIVOTEK.
- Zajistěte připojení napájecího kabelu do zásuvky s uzemněním nebo ekvivalentní.

Warnung vor der Installation

Deutsch

- Das Produkt muss an einem schwer zugänglichen Ort installiert und geschützt werden, der von Stößen oder starken Vibrationen geschützt ist. Zum Beispiel an dem Ort, an dem die Überwachungskameras nach unten schauen oder in hohen Positionen installiert sind, wie beispielsweise an einem Mast, einer Wand oder mindestens 3 Meter über dem Boden.
- Das Produkt sollte in Übereinstimmung mit den örtlichen Gesetzen und Vorschriften verwendet werden.
- Installieren Sie das Produkt nicht auf einer instabilen Halterung oder Oberfläche.
- Zerlegen Sie die Kamera nicht und führen Sie keine Wartungsarbeiten durch, wenn das Gerät an die Stromversorgung angeschlossen ist.
- Vor der Installation sollte das Produkt in einer trockenen und belüfteten Umgebung gelagert werden.
- Verwenden Sie nur Zubehör, das den technischen Spezifikationen des Produkts entspricht.
- Bitte wenden Sie sich an die zertifizierten Händler von VIVOTEK für Netzteile.
- Stellen Sie sicher, dass das Netzkabel an eine Steckdose mit Erdungsanschluss oder eine gleichwertige Steckdose angeschlossen ist.

Advarsel inden installation

Dansk

- Das Produkt muss an einem schwer zugänglichen Ort installiert und geschützt werden, der von Stößen oder starken Vibrationen geschützt ist. Zum Beispiel an dem Ort, an dem die Überwachungskameras nach unten schauen oder in hohen Positionen installiert sind, wie beispielsweise an einem Mast, einer Wand oder mindestens 3 Meter über dem Boden.
- Das Produkt sollte in Übereinstimmung mit den örtlichen Gesetzen und Vorschriften verwendet werden.
- Installieren Sie das Produkt nicht auf einer instabilen Halterung oder Oberfläche.
- Zerlegen Sie die Kamera nicht und führen Sie keine Wartungsarbeiten durch, wenn das Gerät an die Stromversorgung angeschlossen ist.
- Vor der Installation sollte das Produkt in einer trockenen und belüfteten Umgebung gelagert werden.
- Verwenden Sie nur Zubehör, das den technischen Spezifikationen des Produkts entspricht.
- Bitte wenden Sie sich an die zertifizierten Händler von VIVOTEK für Netzteile.
- Sørg for at tilslutte netledningen til en stikkontakt med jordforbindelse eller tilsvarende.

Warning Before Installation

English

- Power The product must be installed and protected in a location that is not easily accessible, and is away from impacts or heavy vibration. For example, at the location where the surveillance cameras are looking down or installed at high positions such as on a pole, wall, or at least 3 meters above the ground.
- The product should be used in compliance with local laws and regulations.
- Do not install the product on an unstable mount or surface.

- Do not disassemble the camera or perform maintenance task when power is connected.
- Before installation, the product should be stored in a dry and ventilated environment.
- Use only accessories that comply with the technical specifications of the product.
- Please contact VIVOTEK's certified dealers for power adapters.
- Ensure to connect the power cord to a socket-outlet with earthing connection, or equivalent.

Advertencia antes de la instalación

Español

- El producto debe instalarse y protegerse en un lugar que no sea fácilmente accesible y donde no se someta a impactos o fuertes vibraciones. Por ejemplo, en el lugar donde las cámaras de vigilancia miran hacia abajo o se instalan en posiciones altas, como en un poste, una pared o al menos 3 metros sobre el suelo.
- El producto debe usarse de acuerdo con las leyes y regulaciones locales.
- No instale el producto en un estante o soporte inestables.
- No desmonte la cámara ni realice tareas de mantenimiento cuando esté conectada la alimentación.
- Antes de la instalación, el producto debe almacenarse en un entorno seco y ventilado.
- Use solo accesorios que cumplan con las especificaciones técnicas del producto.
- Póngase en contacto con los distribuidores certificados de VIVOTEK para los adaptadores de corriente.
- Asegúrese de conectar el cable de alimentación a una toma de corriente con conexión a tierra o equivalente.

Avertissement avant installation

Français

- Le produit doit être installé et protégé dans un endroit difficilement accessible, à l'abri des chocs et des vibrations importantes. Par exemple, à l'endroit où les caméras de surveillance sont dirigées vers le bas ou installées à des endroits élevés, par exemple sur un poteau, un mur ou au moins à 3 mètres du sol.
- Le produit doit être utilisé conformément aux lois et réglementations locales.
- Ne pas installer le produit sur un support ou une surface instable.
- Ne démontez pas la caméra et n'effectuez pas de travaux de maintenance lorsque celle-ci est sous tension.
- Avant l'installation, le produit doit être entreposé dans un endroit sec et ventilé.
- N'utiliser que des accessoires conformes aux spécifications techniques du produit.
- Veuillez contacter les revendeurs certifiés VIVOTEK pour les adaptateurs d'alimentation.
- Assurez-vous de brancher le cordon d'alimentation à une prise de courant avec connexion à la terre, ou équivalent.

Avvertenza prima dell'installazione

Italiano

- Il prodotto deve essere installato e protetto in un luogo non facilmente accessibile e lontano da urti o forti vibrazioni. Ad esempio, nel luogo in cui le telecamere di sorveglianza guardano verso il basso o sono installate in posizioni elevate, ad esempio su un palo, un muro o almeno 3 metri dal suolo.
- Il prodotto deve essere utilizzato in conformità con le leggi e i regolamenti locali.
- Non installare il prodotto su un supporto o una superficie instabili.
- Non smontare la fotocamera o eseguire attività di manutenzione quando l'alimentazione è collegata.
- Prima dell'installazione, il prodotto deve essere conservato in un ambiente asciutto e ventilato.
- Utilizzare solo accessori conformi alle specifiche tecniche del prodotto.
- Si prega di contattare i rivenditori certificati di VIVOTEK per adattatori di alimentazione.
- Assicurarsi di collegare il cavo di alimentazione ad una presa dotata di collegamento a terra o equivalente.

インストール前の注意

日本語

- 本製品は手が届きにくく、衝撃や大きな振動のない場所に設置し、保護する必要があります。例えば、監視カメラが見下ろす場所、またはポールの上や壁、床面から3メートル以上の高い位置に設置します。
- 本製品は地域の法律及び規則に従って使用してください。
- 不安定な取付具または表面上に製品を設置しないでください。
- カメラを分解したり、電源が接続されているときにメンテナンスをしたりしないでください。

- セキュリティ基準 (新規則第 34 条の 10): 「本製品は 電気通信事業者 (移动通信会社、固定通信会社、インターネットプロバイダ等) の通信回線 (公衆無線 LAN を含む) に直接接続することができません。本製品をインターネットに接続する場合は、必ずルータ等を經由し接続してください。」
- 設置する前、本製品は乾燥した通気のよい環境に保管してください。
- 本製品の技術仕様に準拠した付属品のみを使用してください。
- 電源アダプタについては VIVOTEK の認定販売店にお問い合わせください。
- 電源が接地された電源コンセントに接続されていることを確認してください。

Peringatan Sebelum Pemasangan

Bahasa Melayu

- Produk harus dipasang dan dilindungi di lokasi yang tidak mudah dijangkau, serta jauh dari benturan atau getaran hebat. Misalnya, di lokasi di mana kamera pengawasan mengarah ke bawah atau dipasang di posisi tinggi seperti di atas tiang, tembok, atau minimal 3 meter di atas tanah.
- Produk harus digunakan sesuai dengan undang-undang dan aturan setempat.
- Jangan memasang produk di atas dudukan atau permukaan yang tidak stabil.
- Jangan membongkar kamera atau melakukan kerja perawatan dalam kondisi daya terhubung.
- Sebelum pemasangan, produk harus disimpan di lingkungan yang kering dan berventilasi.
- Gunakan hanya aksesori yang sesuai dengan spesifikasi teknis produk.
- Silakan hubungi dealer bersertifikat VIVOTEK untuk adapter daya.
- Pastikan untuk menyambungkan kabel daya ke stopkontak dengan sambungan pembumian, atau yang setara.

Waarschuwing voor installatie

Nederlands

- Dit product moet worden geïnstalleerd en beschermd op een plek die niet makkelijk toegankelijk is en niet blootgesteld is aan schokken en trillingen. Bijvoorbeeld, op de plek waar de bewakingscamera's naar beneden staan gericht of zijn geïnstalleerd op hoge posities zoals op een paal, een muur of tenminste 3 meter boven de grond.
- Het product dient te worden gebruikt conform lokale wetgeving en regelgeving.
- Installeer het product niet op een onstabiele standaard of oppervlak.
- Demonteer de camera niet en pleeg geen onderhoud terwijl de stroom is aangesloten.
- Het product moet voor de installatie worden opgeborgen in een droge en geventileerde omgeving.
- Gebruik alleen accessoires die voldoen aan de technische specificaties van het product.
- Neem contact op met gecertificeerde VIVOTEK dealers voor stroomadapters.
- Zorg ervoor dat u het netsnoer aansluit op een stopcontact met aardaansluiting, of gelijkwaardig.

Zalecenia dotyczące bezpieczeństwa

Polski

- Produkt należy zainstalować i zabezpieczyć w miejscu, które nie jest łatwo dostępne i nie jest narażone na silne wstrząsy lub wibracje. Na przykład w miejscu, w którym kamery monitoringu są skierowane w dół lub są zainstalowane na wysokości na słupie, ścianie lub przynajmniej 3 metry powyżej podłoża.
- Produkt należy używać zgodnie z lokalnymi przepisami.
- Nie instalować produktu na niestabilnych mocowaniach lub powierzchniach.
- Nerozebírejte kameru ani neprovádějte její údržbu, pokud je připojená k napájení.
- Produkt przed instalacją należy przechowywać w suchym i dobrze wentylowanym środowisku.
- Używać wyłącznie akcesoriów spełniających specyfikacje techniczne produktu.
- Síťové adaptéry lze získat u certifikovaných prodejců společnosti VIVOTEK.
- Upewnij się, że przewód zasilający jest podłączony do gniazdka elektrycznego z uziemieniem lub równoważnego.

Aviso antes da instalação

Português

- O produto deve ser instalado e protegido em um local que não seja facilmente acessível, e estar longe de impactos ou vibrações fortes. Por exemplo, no local onde as câmeras de vigilância estão olhando para baixo ou instaladas em altas posições como em um poste, parede, ou, pelo menos, 3 metros acima do solo.
- O produto deve ser utilizado em conformidade com as leis e regulamentos locais.

- Não instale o produto em uma montagem ou superfície instável.
- Não desmonte a câmera ou execute tarefas de manutenção quando a alimentação estiver ligada.
- Antes da instalação, o produto deve ser armazenado em local seco e ventilado.
- Utilize apenas acessórios que estejam em conformidade com as especificações técnicas do produto.
- Favor entrar em contato com revendedores certificados da VIVOTEK sobre adaptadores de corrente.
- Certifique-se de conectar o cabo de alimentação a uma tomada conectada à terra ou equivalente.

Перед установкой

Русский

- Это изделие следует устанавливать в защищенном, труднодоступном месте, обеспечивающем защиту от воздействия ударов и сильных вибраций. Например, следует устанавливать камеры наблюдения на большой высоте не менее 3 метров над землей — на столбе или стене, так чтобы камеры были направлены вниз.
- Эксплуатация изделия должна осуществляться в соответствии с местными законами и нормами.
- Не устанавливайте это изделие на неустойчивых креплениях или поверхностях.
- Не разбирайте камеру и не выполняйте процедуры по ее техническому обслуживанию при подключенном питании.
- До установки это изделие следует хранить в сухом, хорошо проветриваемом месте.
- Используйте только принадлежности, отвечающие техническим характеристикам изделия.
- Используйте только принадлежности, отвечающие техническим характеристикам изделия.
- Обязательно подключите шнур питания к розетке с заземлением или к эквивалентной розетке.

العربية

تحذير قبل التثبيت

- يجب تثبيت المنتج وحمايته في موقع لا يمكن الوصول إليه بسهولة، ويكون بعيداً عن التأثيرات أو الاهتزازات الشديدة. على سبيل المثال، في موقع حيث تنظر كاميرات المراقبة إلى أسفل أو تم تثبيتها في مواقع عالية على سبيل المثال، على عمود أو جدار أو على الأقل 3 أمتار فوق الأرض.
- يجب استخدام المنتج وفقاً للقوانين واللوائح المحلية.
- لا تقم بتثبيت المنتج على حامل أو سطح غير مستقر.
- لا تقم بفك الكاميرا أو تجر مهمة الصيانة أثناء توصيل الطاقة.
- قبل التثبيت، يجب أن يتم تخزين المنتج في بيئة جافة وجيدة التهوية.
- استخدم فقط الملحقات التي تتوافق مع المواصفات الفنية للمنتج.
- يُرجى الاتصال بتجار VIVOTEK المعتمدين لمهايئات الطاقة.
- تأكد من توصيل سلك الطاقة بمنفذ مقبس مزود بوصلة أرضية أو ما يعادله.

安装警告

简体中文

- 本产品必须安装在不易接近的地点，妥善保护，避免受到冲击或强烈振动。例如，安装在可让监控摄像头保持俯视的地点或较高位置，如支柱、墙壁或距地面至少 3 米的位置。
- 应依当地法律法规使用本产品。
- 请勿将本产品安装在不平稳的支架或平面上。
- 切勿在接通电源的情况下拆卸摄像头或进行维护。
- 安装前，应将本产品存放在干燥、通风的环境下。
- 仅使用符合本产品技术规格的配件。
- 如需电源适配器，请联系 VIVOTEK 认证经销商。
- 确保电源是连接于有接地的电源插座。

Varning innan installation

Svenska

- Produkten måste installeras och skyddas på en plats som inte är lättillgänglig, där den inte utsätts för stötar och kraftiga vibrationer. Till exempel på en plats där övervakningskamerorna tittar ner eller installeras på höga positioner som på en stolpe, en vägg eller minst 3 meter ovanför marken.
- Produkten ska användas i enlighet med lokala lagar och föreskrifter.
- Installera inte produkten på ett instabilt stativ eller en instabil yta.
- Plocka inte isär kameran eller utför inget underhåll när strömmen är ansluten.

- Innan installation ska produkten förvaras i en torr och ventilerad miljö.
- Använd endast tillbehör som överensstämmer med produktens tekniska specifikationer.
- Kontakta VIVOTEKs certifierade återförsäljare för nätadapterar.
- Se till att ansluta nätsladden till ett uttag med jordad anslutning eller motsvarande.

安裝前應注意事項

繁體中文

- 本產品必須安裝並放置在不容易拿取的位置，且必須遠離衝擊或劇烈震動。例如，請安裝在讓監視攝影機能朝下監看的位置，或安裝在電線杆、牆壁或離地至少 3 公尺的高處。
- 本產品之使用必須符合當地的法律與規定。
- 請勿將產品安裝在不平穩的支架或平面上。
- 請勿在連接電源的情況下拆解攝影機或執行維護工作。
- 在安裝本產品前，請將產品存放在乾燥且通風的環境。
- 僅使用符合本產品技術規格的配件。
- 如需電源供應器，請聯繫 VIVOTEK 認證經銷商。
- 確保電源是連接於有接地的電源插座。

Kurulum Öncesi Uyarılar

Türkçe

- Ürün kolayca erişilemeyen ve darbe veya ağır titreşimden uzakta bir yere kurulmalı ve korunmalıdır. Örneğin, güvenlik kameralarının aşağıya baktığı veya direk, duvar gibi yüksek pozisyonlara veya yerden en az 3 metre yükseğe kurulduğu yerler.
- Ürün, yerel yasa ve yönetmeliklerle uyumlu kullanılmalıdır.
- Ürünü, dengesiz bir yere veya yüzeye kurmayın.
- Güç bağlandığında kamerayı sökmeyin veya bakım işi yapmayın.
- Kurulumdan önce, ürün kuru ve havalandırılmış bir ortamda saklanmalıdır.
- Yalnızca ürünün teknik özelliklerine uygun aksesuarları kullanın.
- Güç adaptörleri için VIVOTEK'in yetkili bayileriyle temasa geçin.
- Güç kablosunu topraklama bağlantısı veya eşdeğeri olan bir prize bağladığınızdan emin olun.

設備名稱：網路影像錄影機 Equipment name: Network Video Recorder		型號 (型式): ND9326P, ND9426P Type designation (Type): ND9326P, ND9426P				
單元 Unit	限用物質及其化學符號 Restricted substances and its chemical symbols					
	鉛 (Pb)	汞 (Hg)	鎘 (Cd)	六價鉻 (Cr ⁺⁶)	多溴聯苯 (PBB)	多溴二苯醚 (PBDE)
塑膠組件	○	○	○	○	○	○
電路板組件	○	○	○	○	○	○
線材組件	○	○	○	○	○	○
螺絲組件	○	○	○	○	○	○
備考 1. "超出 0.1wt%" 及 "超出 0.01wt%" 係指限用物質之百分比含量超出百分比含量基準值。 Note 1: "Exceeding 0.1 wt%" and "exceeding 0.01 wt%" indicate that the percentage content of the restricted substance exceeds the reference percentage value of presence condition. 備考 2. "○" 係指該項限用物質之百分比含量未超出百分比含量基準值。 Note 2: "○" indicates that the percentage content of the restricted substance does not exceed the percentage of reference value of presence. 備考 3. "—" 係指該項限用物質為排除項目。 Note 3: "—" indicates that the restricted substance corresponds to the exemption.						
最大消耗功率 Max. power consumption		---				
運作溫度 Operating temperature		---				

重要安全規範及資訊：您國家的法律可能會禁止使用監控裝置。此效能優異的網路攝影機不僅隨時能夠連接網路，更能應用於具有彈性的監視系統，使用者安裝本產品前，必須確保其預期操作用途完全合法。首先請確認所取得的產品完整無誤。請先注意「快速安裝指南」內的警告，再安裝本網路攝影機；並確實遵守指示，避免組裝及安裝錯誤，造成產品損壞，如此亦能確保本產品受到妥善運用。

宣告甲類 /Class A CNS 15936 警語：為避免電磁干擾，本產品不應安裝或使用於住宅環境。

警告：1. 如果使用電源轉接器供電，此轉接器應正確接地。2. 安裝和維護服務只能由合格的技術人員進行。3. 執行維護任務時，請中斷設備電源。4. 請只使用經過 UL 認證的直流電源和有限的電源，來使用攝影機。5. LPS 認證。電源供應器應附有 UL 認證和 LPS 標誌。6. 電源供應也應滿足使用國家 / 地區的任何安全和規範要求。7. 攝影機安裝位置應距離建築物屋簷至少 10 公分。8. 產品應安裝在建築物屋簷下，並避免外部電線直接暴露在陽光和水環境中。9. 電源線必須連接至有接地線的插座。10. 攝影機只能連接到 PoE 網絡，不能路由到外部設備。11. 如須購買電源供應器，請聯絡 VIVOTEK 認證經銷商或代理商。12. 使用 RTC battery 需加註電池警語如下：a. 若置換不同型式之電池有起火或爆炸風險。b. 如果更換後的電池型式不正確，會有爆炸的風險。並請根據指示，處理廢棄電池。c. 請根據指示丟棄使用過的電池。13. 注意壁掛螺絲直徑及長度。

UL Warning: 1. If powered by a power adapter, the adapter should be properly grounded. 2. Installation and maintenance service should only be performed by qualified technicians. 3. Disconnect power from the unit when performing a maintenance task. 4. Use the camera only with a DC power supply that is UL listed, and limited power source (LPS) certified. The power supply should bear the UL listed and LPS marks. The power supply should also meet any safety and compliance requirements for the country of use. 5. The camera is only to be connected to PoE networks without routing to outside plants. 6. For PoE connection, use only UL listed I.T.E with PoE output. Please contact VIVOTEK's certified dealers for power adapters. 7. Ground wire to the grounding position: a. The minimum ground screw type is 3.5mm. b. The minimum wire gauge is 18AWG: b-1. Use green/yellow (green with yellow stripe) ground wires. b-2. Use a knurled washer for securing the grounding screw. 8. The camera should be installed at least 10 centimeters away from the eave of a building. The product will be installed under the eaves of the building, and will avoid direct exposure of the external wire to the sun and water environment.

CAUTION: RISK OF EXPLOSION IF BATTERY IS REPLACED BY AN INCORRECT TYPE. DISPOSE OF USED BATTERIES ACCORDING TO THE INSTRUCTIONS.

The equipment comes with a RTC battery. Note the following: 1. Replacement of a battery with an incorrect type that can defeat a safeguard (for example, in the case of some lithium battery types). 2. Disposal of a battery into fire or a hot oven, or mechanically crushing or cutting of a battery, that can result in an explosion. 3. Leaving a battery in an extremely high temperature surrounding environment that can result in an explosion or the leakage of flammable liquid or gas. 4. A battery subjected to extremely low air pressure that may result in an explosion or the leakage of flammable liquid or gas. 5. disposal of a battery into fire or a hot oven, or mechanically crushing or cutting of a battery, that can result in an explosion.

Please contact authorized distributors for warranty and RMA service.

Warranty www.vivotek.com/support/warranty

RMA www.vivotek.com/support/rma

C Using Device Manager and Shepherd

Using Device Manager to Locate and Identify NVR on the LAN

Device Manager is a client-server device management tool designed to streamline the installation and configuration of multiple VIVOTEK devices, primarily IP cameras. By installing the Device Manager client, users can manage VIVOTEK devices by connecting to a Device Manager server—either over the local network or remotely via port forwarding.

Users can locate the IP address of the NVR they want to access on the local network by following the steps below using the Device Manager.

- step 1. Download and install the Device Manager application from VIVOTEK's official website: https://www.vivotek.com/products/software/device_manager
- step 2. Device Manager will launch automatically after installation and prompt you to create an account during the initial setup.
- step 3. Log in and click the **Add Device** button to allow Device Manager to detect NVRs on your local network.
- step 4. Identify the NVR by its MAC address, then click **Add**.

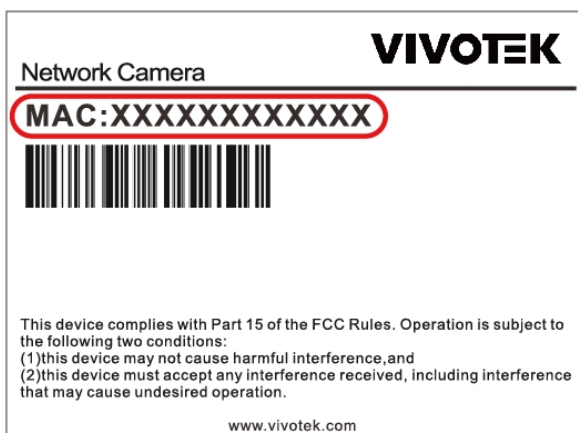

step 5. To access the NVR's web interface, do one of the following:

- Enter the NVR's IP address into a supported web browser.
- Double-click the NVR entry in the Device Manager interface to open it directly.

The screenshot shows the 'NVR' tab in the Device Manager application. The interface has a dark theme. At the top, there are navigation tabs for 'Camera', 'NVR', and 'Others'. Below the tabs is a table with columns for Status, Model, Host Name, IP, MAC, and Firmware. Two NVRs are listed: one 'Unauthorized' (ND9542P) and one 'Unreachable' (ND9326P).

Status	Model	Host Name	IP	MAC	Firmware
Unauthorized	ND9542P		10.42.2.33	0002D1A35CDF	5.0.0.5
Unreachable	ND9326P		10.42.2.119	0002D1AAAFB2	4.6.0.6.v0711

Using Shepherd to Locate and Identify NVRs on the LAN

Shepherd is a standalone device management tool designed to simplify the installation and configuration of multiple VIVOTEK devices. It is ideal for environments where software installation is not permitted.

Shepherd is a standalone device management tool designed to simplify the installation and configuration of multiple VIVOTEK devices. It is ideal for environments where software installation is not permitted.

step 1. Download and extract the Shepherd application from VIVOTEK's official website:

<https://www.vivotek.com/products/software/shepherd>

step 2. Navigate to the extracted folder and run the Shepherd application.

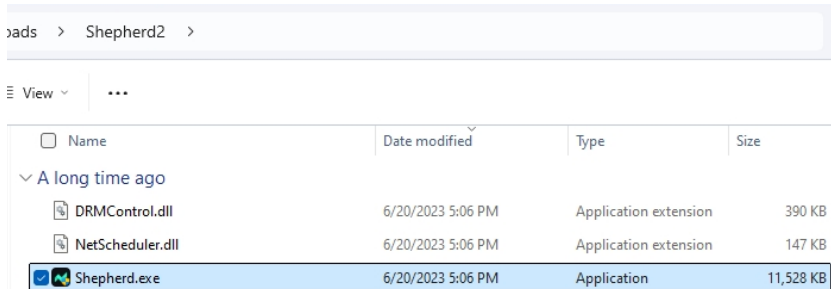

step 3. Step 3. Identify the NVR by its MAC address, then click Add.

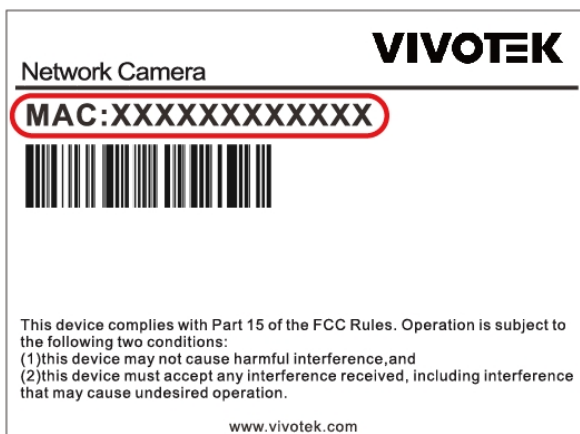

step 4. To access the NVR's web interface, do one of the following:

- Enter the NVR's IP address into a supported web browser.
- Double-click the NVR entry in the Shepherd interface to open it directly.

D Safety and Compliance

Safety Instructions

General Safety

1. The NVR must be properly grounded.
2. The maximum total power of all PoE ports is 180 W.
3. The maximum power for each PoE port is 30 W.

Power & PoE

1. The maximum total power of all PoE ports is 180 W.
2. The maximum power for each PoE port is 30 W.
3. The NVR must only be connected to PoE networks without routing to outside plants.
4. For PoE connections, use only UL-listed I.T.E. equipment with PoE output.
5. Use shielded cables in high-noise environments where crosstalk and EMI may occur.
6. Some low-quality Ethernet cables with smaller core diameters may reduce transmission performance. For uplink connections, use CAT5e or CAT6 cables with 24 AWG, as a thicker 24 AWG core offers less resistance than 26 AWG or 28 AWG cables, providing better stability and reliability.

Power Supply Notice

Use the NVR only with a UL-listed DC power supply. The power supply must bear the UL mark and comply with the applicable safety and regulatory requirements of the country of use.

Conformité réglementaire

La NVR ne doit être raccordée qu'à des réseaux PoE, sans routage vers des installations extérieures.

Pour les raccordements PoE, utilisez uniquement un équipement de TI homologué UL, avec une sortie PoE.

REMARQUE : n'utilisez la NVR qu'avec un bloc d'alimentation CC homologué UL, ainsi qu'avec une alimentation certifiée. Le bloc d'alimentation doit porter les indications d'homologation UL. Il doit également répondre aux exigences en matière de sécurité et de conformité relatives au pays d'utilisation.

Battery Safety

Avoid the following practices when using batteries:

1. Replacing a battery with an incorrect type, which may disable a safeguard (for example, certain lithium battery types).
2. Disposing of a battery in fire or a hot oven, or mechanically crushing or cutting a battery, which may result in an explosion.

3. Leaving a battery in an environment with extremely high temperature, which may result in an explosion or the leakage of flammable liquid or gas.
4. Subjecting a battery to extremely low air pressure, which may result in an explosion or the leakage of flammable liquid or gas.



ACA (Australian Communications Authority)
CAUTION

RISK OF EXPLOSION IF BATTERY IS REPLACED BY AN INCORRECT TYPE.
DISPOSE OF USED BATTERIES ACCORDING TO THE INSTRUCTIONS

Regulatory Compliance



Federal Communications Commission (FCC) Statement

This Equipment has been tested and found to comply with the limits for a Class A

This Equipment has been tested and found to comply with the limits for a Class A digital device, pursuant to Part 15 of the FCC rules. These limits are designed to provide reasonable protection against harmful interference when the equipment is operated in a commercial environment. This equipment generates, uses and can radiate radio frequency energy and, if not installed and used in accordance with the instructions, may cause harmful interference to radio communications. Operation of this equipment in a residential area is likely to cause harmful interference in which case the user will be required to correct the interference at his own expense.

Warning

[A shielded-type power cord is required in order to meet FCC emission limits and also to prevent interference to the nearby radio and television reception. It is essential that only the supplied power cord be used.]

[Use only shielded cables to connect I/O devices to this equipment.]

You are cautioned that changes or modifications not expressly approved by the party responsible for compliance could void your authority to operate the equipment.

[]: depend on EUT condition.

VCCI 規制について

この装置は、クラスA情報技術装置です。この装置を住宅環境で使用すると電波妨害を引き起こすことがあります。この場合には使用者が適切な対策を講ずるよう要求されることがあります。

VCCI-A



Waste Electrical & Electronic Equipment (WEEE) Directive

For Private Households

This symbol on the products and/or accompanying documents means that used electrical and electronic products should not be mixed with general household waste.

For proper treatment, recovery and recycling, please take these products to designated collection points, where they will be accepted on a free of charge basis. Alternatively, in some countries you may be able to return your products to your local retailer upon the purchase of an equivalent new product.

Disposing of this product correctly will help to save valuable resources and prevent any potential negative effects on human health and the environment which could otherwise arise from inappropriate waste handling. Please contact your local authority for further details of your nearest designated collection point.

Penalties may be applicable for incorrect disposal of this waste, in accordance with national legislation.

For Business Users in the European Union

If you wish to discard electrical and electronic equipment, please contact your dealer or supplier for further information.

For Users in Other Countries Outside the European Union

This symbol is only valid in the European Union. If you wish to discard this product, please contact your local authorities or dealer and ask for the correct method of disposal.

Licensing Notices

HEVC Advance License Notice

THIS PRODUCT IS SOLD WITH A LIMITED LICENSE AND IS AUTHORIZED TO BE USED ONLY IN CONNECTION WITH HEVC CONTENT THAT MEETS EACH OF THE THREE FOLLOWING QUALIFICATIONS: (1) HEVC CONTENT ONLY FOR PERSONAL USE; (2) HEVC CONTENT THAT IS NOT OFFERED FOR SALE; AND (3) HEVC CONTENT THAT IS CREATED BY THE OWNER OF THE PRODUCT. THIS PRODUCT MAY NOT BE USED IN CONNECTION WITH HEVC ENCODED CONTENT CREATED BY A THIRD PARTY, WHICH THE USER HAS ORDERED OR PURCHASED FROM A THIRD PARTY, UNLESS THE USER IS SEPARATELY GRANTED RIGHTS TO USE THE PRODUCT WITH SUCH CONTENT BY A LICENSED SELLER OF THE CONTENT. YOUR USE OF THIS PRODUCT IN CONNECTION WITH HEVC ENCODED CONTENT IS DEEMED ACCEPTANCE OF THE LIMITED AUTHORITY TO USE AS NOTED ABOVE.

H.264 / AVC Patent Portfolio License

THIS PRODUCT IS LICENSED UNDER THE AVC PATENT PORTFOLIO LICENSE FOR THE PERSONAL AND NON-COMMERCIAL USE OF A CONSUMER TO (i) ENCODE VIDEO IN COMPLIANCE WITH THE AVC STANDARD ("AVC VIDEO") AND/OR (ii) DECODE AVC VIDEO THAT WAS ENCODED BY A CONSUMER ENGAGED IN A PERSONAL AND NON-COMMERCIAL ACTIVITY AND/OR WAS OBTAINED FROM A VIDEO PROVIDER LICENSED TO PROVIDE AVC VIDEO. NO LICENSE IS GRANTED OR SHALL BE IMPLIED FOR ANY OTHER USE. ADDITIONAL INFORMATION MAY BE OBTAINED FROM MPEG LA, L.L.C. SEE [HTTP://WWW.MPEGLA.COM](http://www.mpegla.com)

VIVOTEK

A Delta Group Company

www.vivotek.com

DESIGN AND SPECIFICATIONS ARE SUBJECT TO CHANGE WITHOUT NOTICE
Copyright © 2025 VIVOTEK INC. All rights reserved.