

Industrial 16-port Fast Ethernet plus 4-port Gigabit Managed Switch

JetNet 5020G

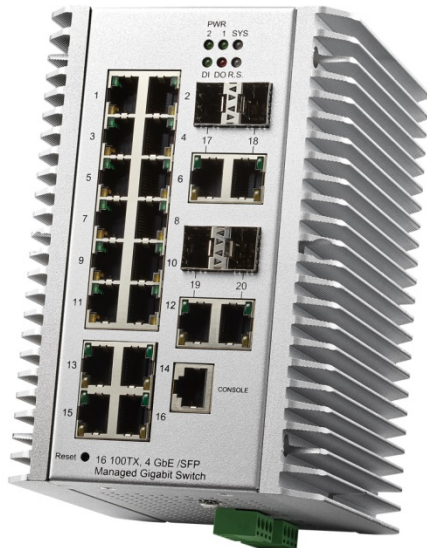

The JetNet 5020G is a high port density Ethernet Switch supports 16 ports Fast Ethernet, and 4 ports Gigabit Ethernet in RJ-45 or SFP for fiber connection. It is designed for field site data convergence to backbone network and up to control data center. The highly heavy industrial Electric-Magnetic Compatibility level, wide operating temperature and voltage provide excellent environmental tolerance to bear the applications which are installed in outdoor or the environment with high noise interference, such as factory, railway track site or Intelligent Traffic Control System (I.T.C.S.). It also adopts comprehensive network control protocols to enhance network transport performance. With those brilliant system design and network features, the JetNet 5020G will be the best network transmission device for your industrial Ethernet Switch solution.



9KB
Jumbo Frame

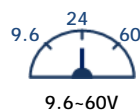

Feature

- ▶ 16 10/100Base-TX, 4 Gigabit RJ-45/SFP combo ports
- ▶ 100Mbps, 1000Mbps Optical Fiber Connection
- ▶ 11.2Gbps Non-Blocking, High-Speed Network Switching Fabric
- ▶ 1.5Mbytes shared memory for packet buffering
- ▶ 9Kbytes Jumbo Frame for large data transmission
- ▶ Network Redundancy - MSR (Multiple Super Ring), ITU-T G.8032 ERPS, RSTP, MSTP, Super Chain
- ▶ Fully Device Management - SNMP v1/v2c/v3, RMON, Web UI, Telnet and Local Console
- ▶ Friendly Device and Network Topology recovery utility - Korenix View, Korenix NMS
- ▶ Advanced Network Security -MAC security, IEEE 802.1x Port-Based access control, IEEE 802.1x Radius Server authentication, 802.1x MAB, Deny of Service, IP Source Guard, Deny of ARP Inspection
- ▶ Layer 2 Network Performance - IEEE802.1Q VLAN, Private VLAN, Trunk, Traffic Filtering, DHCP Server/Client, Traffic Prioritize, Forwarding Rate Control
- ▶ Layer 2 plus Packet Filtering - MAC based, SA/DA of IP, SA/DA of TCP/UDP, ICMP
- ▶ Real Hardware Watchdog compliant with Railway / Heavy Industrial application
- ▶ Multiple Event Dry Relay Output, Semi Digital Input
- ▶ High Level Electromagnetic interference immunity
- ▶ Compliance with Heavy Industrial EMC, Track Side EMC
- ▶ Railway Track Side, Road Traffic Control or Harsh Applications

High Performance Data Acquisition

The Ethernet Switch designed with high port density interface for field data acquisition, and exchange with the data center. With the highest Switch Fabric and data buffer, the JetNet 5020G approached seamless connective for field and center offered 9Kbytes packet forwarding ability and excellent burst stream management technology to enable highest network performance.

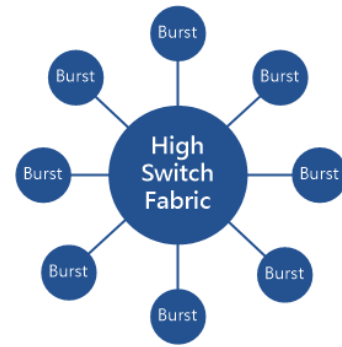

Flexible Uplink Media for Network Architecture Extension

In the metro network architecture, the optical fiber is commonly to use for uplink connection. The JetNet 5020G offers 4 RJ-45/SFP combo ports with various types of speed modes with flexible connectivity, including 100Mbps, 1000Mbps in single-mode or multi-mode fiber cable, as well as RJ-45 copper connections. Those ports can be configure as many as several different combinations for network extension.

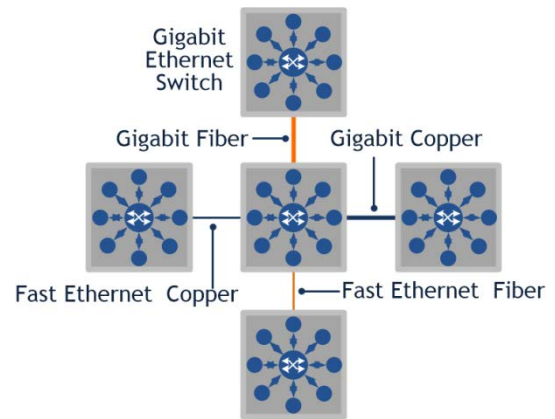

Fiber Optical Quality Monitoring

The fiber optical transmission quality may become unstable, due the moisture, dust or laser diode senile. To reduce the threat of signal broken, the Ethernet Switch provides Digital Diagnostic Monitoring (DDM) to recognize the specification of fiber transceiver. The DDM function enabled user to monitor the launched power, received signal strength, temperature and also alerts user if fiber signal quality is getting poor.

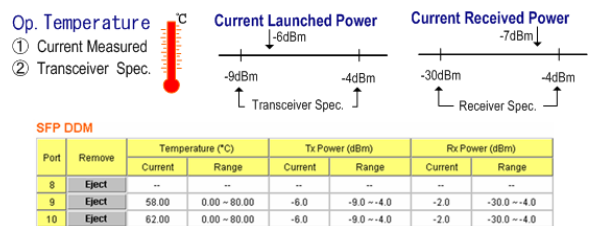

Redundant Solution- Multiple Super Ring (MSR™)

The MSR is a seamless network redundant technology, which includes various technologies for different network redundancy topologies and applications. It includes Rapid Super Ring (RSR™), Rapid Dual Homing (RDH™), MultiRing™ and TrunkRing™. With those network redundant technologies, a node can be configured to multiple rings with failover time less than 20ms, and zero of restoration time.

MSR Multiple Super Ring

Rapid Super Ring

- RM Auto-Select
- Seamless Restoration
- mSec Recovery Time
- Failed Ring Port Together with RM
- Ring Failure LED

MultiRing

- Ring coupling in one unit
- 4 Gigabit Rings
- 8 Fast Ethernet Rings

Rapid Dual Homing

- Multiple Uplink Path
- One to One upper
- Many to One upper
- One to Many upper
- Seamless Restoration

TrunkRing

- Active with Port trunk/LACP with MSR, RSR
- Load Balancing
- Auto Backup

Rapid Super Ring (RSR™) Technology

The Rapid Super Ring (RSR™) technology provides advanced Ring Redundancy Technology with fast ring recovery time for Gigabit ring uplink, and the Ring-Master (R.M.) can be auto-selected by RSR™ engine. One of Ring path of R.M. is primary path; the other is block path for standby. Once the primary path failed, the 2nd path will be recovered in mini second. Besides, the seamless ring restoration time is shortened to zero in R.M. auto-selection mode.

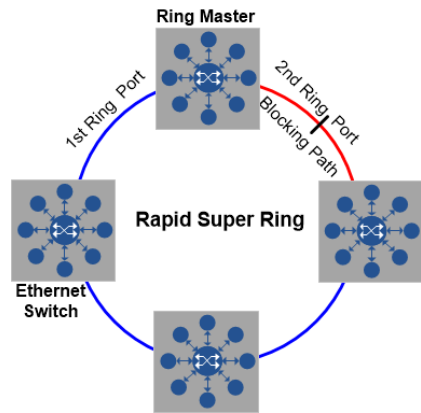

Rapid Dual Homing (RDH™) Technology

The Rapid Dual Homing (RDH™) is designed to engaged Korenix Rapid Super Ring and other vendors Ethernet Switch. It provides easy configuration and multiple redundancies, the failover time is fast than RSTP, and restoration time is zero. Uplinks can be auto-detected, and gathered into groups. Each group path is sorted into primary, secondary, and standby. The Link Aggregation is also integrated into RDH™. An uplink can be a single or several links as a trunk, which provides better redundancy and capacity.

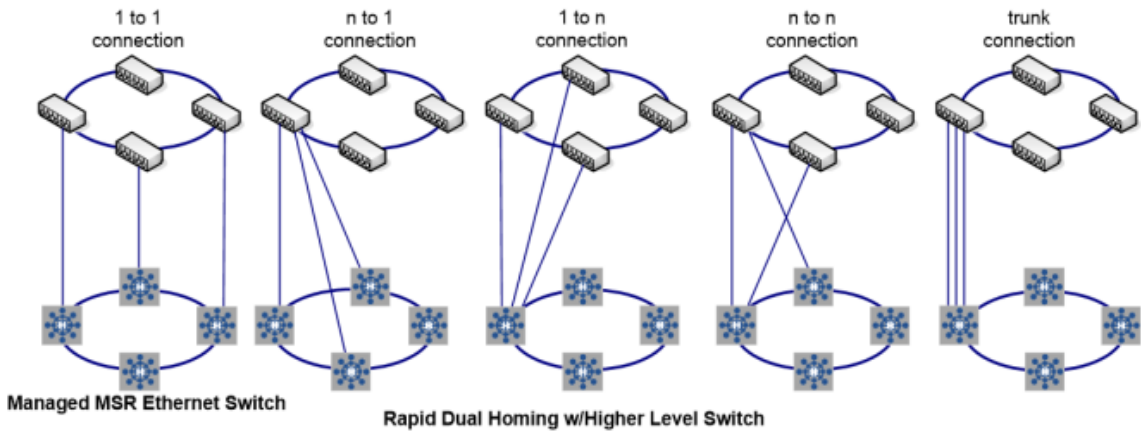

TrunkRing Technology

The TrunkRing is the combination of two technology of RSR and the link aggregation, and takes the advantage of aggregation to increase the path bandwidth. The ring links can be either asymmetric or symmetric. The ring will open only if all the links are broken, and users can enhance the redundancy at different location in accordance to be the need, the path with less bandwidth is more likely to be used as the backup path for restoring the network to full play capacity.

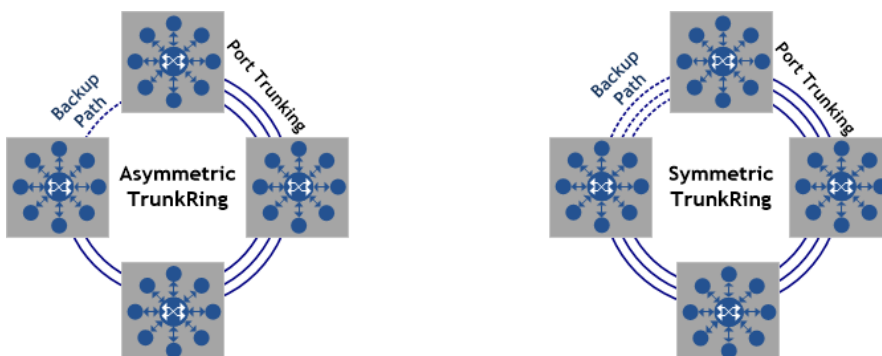

MultiRing Technology

The MultiRing™ provides easier connectivity between two or more ring networks. The simplest sample is to connect two rings by single device. User can extend the network by linking multiple rings into a line or multiple directions. The MultiRing™ has great diversity of various ring technology, when MutliRing™ enabled, the Switch can connect TrunkRing™, RSR™ together and simultaneously provide more high-speed ring connectivity. It provides extensibility while keeping the great compatibility.

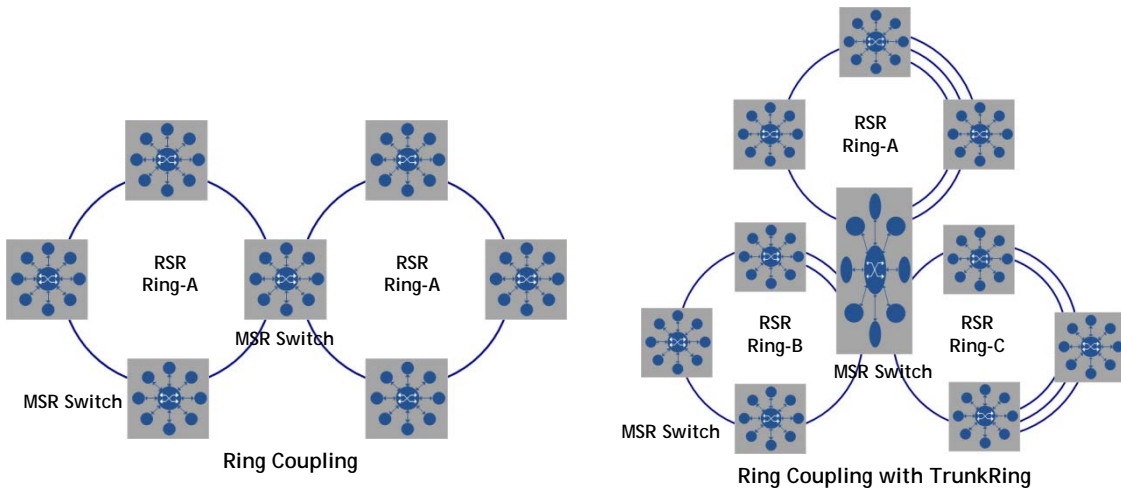

Super Chain Technology

The Super Chain is a new Ring technology that provides a cost-effective way to ring nodes with presented ring to approached flexible, scalability and easy construction.

The Super Chain includes 2 borders that connect with other ring by edge port, and the reset nodes are member. Once the ring broken, the standby edge port will backup in few mini seconds, and seamless restoration time when the broken path recovery. Besides, users can add new super ring with existed super ring to approach the flexibility to saving the construction cost.

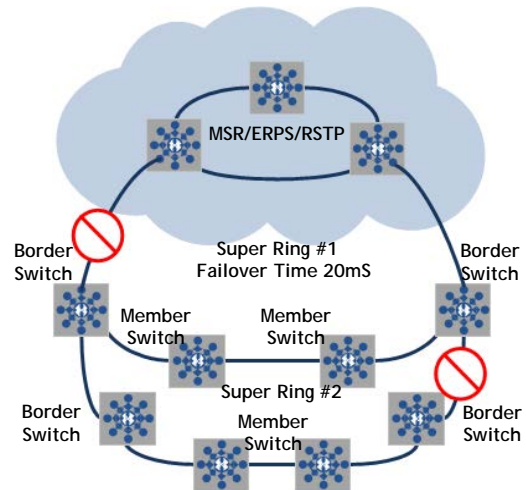

Seamless Ring Port Restoration

Seamless restoration can restore a failed ring without causing any loop problem, topology change, and packet loss. With a zero second restoration time, this mechanism eliminates any unstable status and guarantees the applications are running non-stop. It ensures MSR™ Ring can be harmonic with RSTP protocol.

In the figure, the RM will change to another one which nearby the broken path.

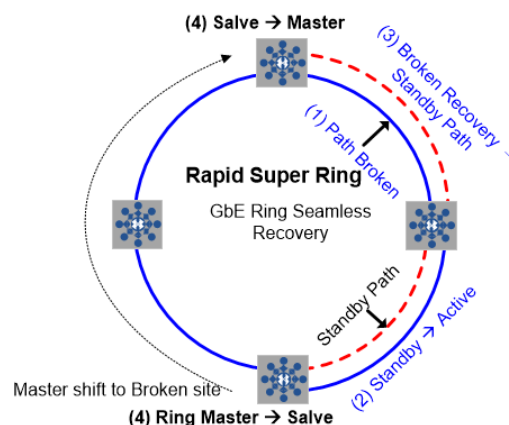

ITU-T G.8032 ERPS * See Note-1

The ITU-T G.8032 Ethernet Ring Protection Switching (ERPS) is a ring technology defined by ITU-T. It includes 2 version ring protocols, ERPS v1 and v2. The v1 supports single ring, and v2 is based on VLAN concept to construct comprehensive ring architecture that engaged several major rings and sub ring. The ERPS protocol is similar to MSR technology with one major host -RPL Owner and several of RPL nodes. The ring restoration and recovery time of ERPS are smaller than 50ms. However, the ERPS is an open Ethernet ring redundant protocol that enabled different vendor's ring switch can be integrated together with great network redundancy.

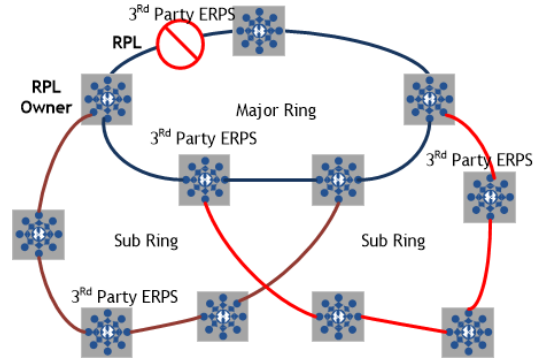

Advanced Cyber Security * See Note-2

The JetNet Switch supports several advanced network security functions to ensure the IT system and data will not get any threat from Cyber network (Internet). The advanced security function includes DHCP Snooping protection, Dynamic ARP Inspection (DAI), IP source guard (IPSG), Distribute Denial-of-Service protection, IPv6 Route Advertisement (RA) Guard and IEEE 802.1x MAB. The Cyber Security function will be released later.



DHCP Snooping Protection

The DHCP Snooping is a series of techniques applied to the security of an existing DHCP network. With the DHCP Snooping, the DHCP Server will manage the network access and permit the access with specific IP and specific MAC address from specific Switch port can access the network. It also provides the protection to avoid the attacker added DHCP server into a secure network, and try to control hall DHCP process. Once the Switch detects the phenomena, the attack's or intruder's port will be locked to secure network.

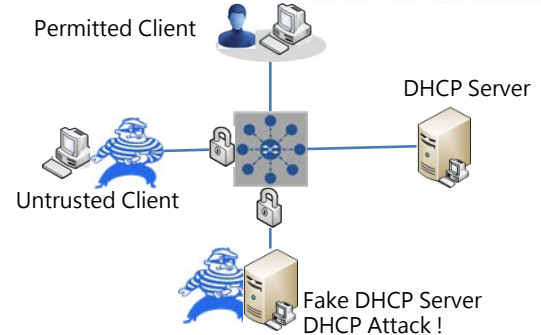

Dynamic ARP inspection Protection

The Dynamic ARP Inspection (DAI) is a security feature that prevents ARP attack. The Switch receives one ARP packet on an untrusted port, the switch compares the IP-to-MAC address binding with entries from the DHCP Snooping database or ARP access-lists. If there is no match, the ARP packet will be dropped by the Switch to ensure network performance.

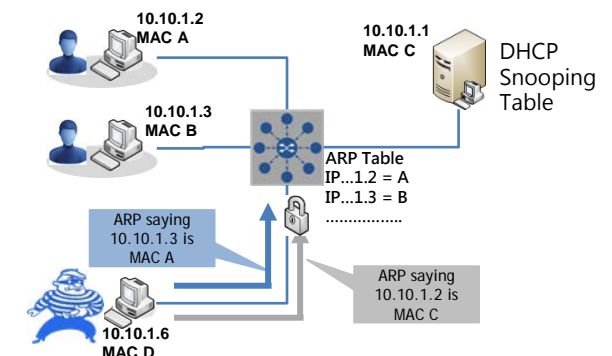

IP Source Guard (IPSG)

IP Source Guard is a security feature that restricts IP traffic on untrusted Switch port by filtering traffic based on the DHCP snooping binding database or manually configured IP source bindings. This feature helps prevent IP spoofing attacks when a host tries to spoof and use the IP address of another host.

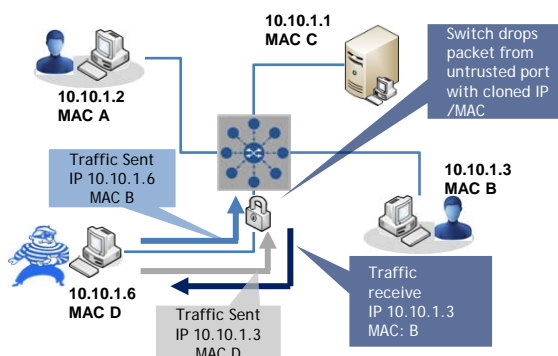

Denial of Service (DoS) Prevention

In the internet, a Denial of Service (DoS) or Distributed Denial-of-service (DDoS) attack is an attempt to make a computer or network resource unavailable for intended operating. For the managed Ethernet Switch, the attacker may send lot of service inquire packets to the Switch, and it may caused Switch's CPU get slowly and the network may malfunction. With the DoS protection, the Switch will far way the treat of zombie computer, and keep the network operating as well.

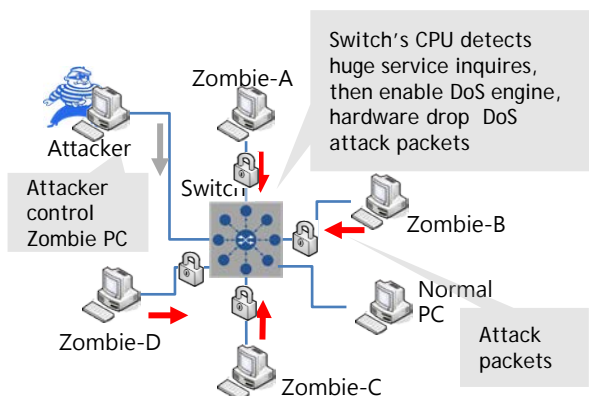

IPv6 Route Advertisement (RA) Guard

When operating IPv6 in a shared layer-2 (L2) network segment without complete Secure Neighbor Discovery (SEND) support by all devices connected or without the availability of the infrastructure necessary to support SEND, there is always the risk of operational problems due to rogue Router Advertisements (RAs) that generated maliciously or unintentionally by unauthorized or improperly configured routers connecting to the network segment. To avoid rogue RAs, the L2 Switch adapts the capable of identifying invalid RAs and blocking them.

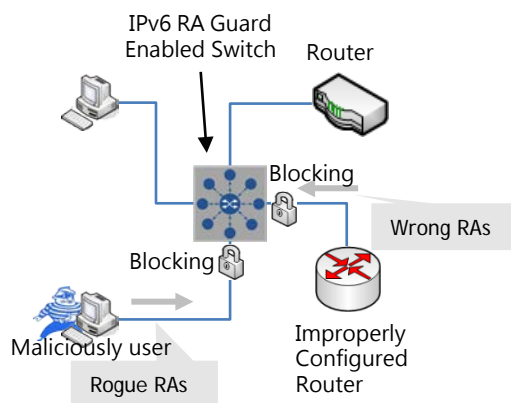

IEEE802.1x MAB,

The 802.1x MAB provides the feature to assist remote device which can't support 802.1x access control authentication, but still need connect to a secure network. The Switch can active as 802.1x agent to perform RADIUS-Access-Request after 802.1x time out and Switch learned MAC address. The Sticky port feature is only permit the port to be connected one time. Once, the port is disconnected, the port will be disable until the administrator to enable it. Both of features is simply, but high efficiency to protect network safety.

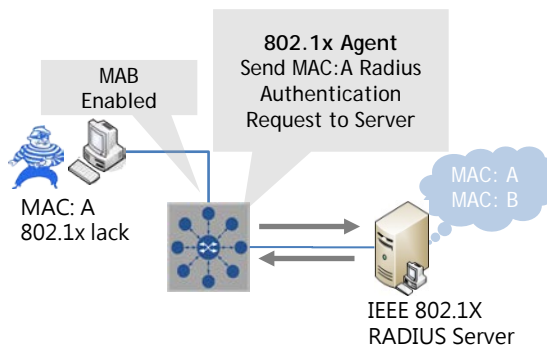

Harsh Industrial Environment

The JetNet 5020G is designed with IP-30 grade metal housing and integrated with rigid aluminum heat-sink enabled the Switch system to survive under extreme environment temperature -40~75°C. The redundant power system provides non-stop communication if one of power source defect. It also accepts wide range power input - 9.6V~60Vdc with polarity reverse protection.

In the industrial field application, there may exist huge noise interference caused communication stop. The JetNet 5020G compliance with NEMA-TS2 and Railway Track Side EMC. The testing severity also exceeds the standards of EN50121-4 and IEC 61000-6-2/IEC61000-6-4 Heavy Industrial. The performance of testing approached criteria A with non-stop communication.

	JetNet 5020G	Track Side EN50121-4	Heavy Industrial EMC
EN55022 Radiation	Class A	Class A	Class A
IEC61000-4-2 ESD	6k/8K , Criteria-A	6K/8K, Criteria-B	4K/6K, Criteria-B
IEC61000-4-3 RS	20V/m, Criteria-A	20V/m, Criteria-A	10V/m, Criteria-A
IEC61000-4-4 EFT	2KV, Criteria-A	2KV, Criteria-A	2KV, Criteria-B
IEC61000-4-5 Surge	2KV, Criteria-A	2KV,Criteria-B	1kV, Criteria-B
IEC61000-4-6:CS	10V/m, Criteria-A	10V/m, Criteria-A	10V/m, Criteria-A
IEC61000-4-8:PFMF	300A/m, Criteria-A	300A/m, Criteria-A	30A/m, Criteria-A
IEC61000-4-9:PMF	300A/m, Criteria-A	300A/m, Criteria-A	N/A

Specification

Technology

Standard	IEEE 802.3u 10Base-T Ethernet IEEE 802.3u 100Base-TX Fast Ethernet IEEE 802.3u 100Base-FX Fast Ethernet Fiber IEEE 802.3ab 1000Base-T Gigabit Ethernet copper IEEE 802.3z Gigabit Ethernet Fiber IEEE 802.3x Flow Control and back-pressure IEEE 802.1AB Link Layer Discovery Protocol (LLDP) IEEE 802.1p Class of Service (CoS) IEEE 802.1Q VLAN and GVRP IEEE 802.1Q Double Tag VLAN (QinQ) IEEE 802.1D Rapid Spanning Tree (RSTP) IEEE 802.1S Multiple Spanning Tree Protocol (MSTP) IEEE 802.3ad Link Aggregation Protocol (LACP) IEEE 802.1x Port based Network Access Protocol ITU-T G.8032 ERPS v1/v2 IEEE 1588 PTP
----------	--

Performance

Switch Technology	Store and Forward Technology with 11.2Gbps Non-Blocking Switching Fabric
System Throughput	16.6 Mega packet per second, 64Bytes packet length
CPU Performance	600Mhz MIPS CPU with 10 Seconds Hardware Based Watchdog Timer
System Memory	128Mbytes RAM, 32Mbytes Flash ROM
Transfer packet Size	64Bytes ~9712Bytes (excludes Tag)
MAC address Table	16K
Packet Buffer	1.5Mbytes shared memory
Transfer performance	14,880 pps for Ethernet, 148,800 for Fast Ethernet, 1488,100 for Gigabit Ethernet

Management	
Configuration, monitoring interface	<ul style="list-style-type: none"> In-Band Management: Telnet with SSH, Web-Browser with SSL, IPv4/IPv6 SNMP V1/V2c/V3 with SNMP Trap (4 Trap Stations), RMON Group 1,2,3,9 Out-Band Management: Local RS-232/RJ-45 connector with Cisco like command
System Manage Secure	<ul style="list-style-type: none"> Telnet/Local Console support command like interface with Cisco like commands, and offers 4 management sessions; the system supports SSL for HTTP security, SSH for Telnet security Supports Manage Station with IP Secure function, up to 4 Manage Stations Management Device Login Switch System by Remote RADIUS account/password, key for RADIUS Server authentication
SNMP MIB	MIB II, Bridge MIB, Ethernet Like MIB, VLAN MIB, IGMP MIB< Private MIB
Management Utility	Supports Korenix windows utility with IEEE 802.1AB link Layer Protocol for Device finding and Link Topology Discovery
Network Time Protocol	NTP protocol with daylight saving and localize time sync function
IEEE 1588 PTP	IEEE 1588 Precision Time Protocol v1/v2 with Time Transparent
E-mail Warning	4 receipt E-mail accounts with mail server authentication
System log	Local or remote log server with authentication
System Auto Maintenance	System auto load configuration from USB Flash disk without manual control.
Network Performance	
Port Configuration	Port Link Speed, Link Mode, Link Status and Port Enable/Disable
Port Trunk/ Link Aggregation	IEEE 802.3ad port aggregation and static port trunk, Trunk member up to 8 ports, maximum 10 trunk groups include Gigabit Ethernet port
VLAN	IEEE 802.1Q tag VLAN with 4K VLAN entries, 2K GVRP entries 3 VLAN modes - Trunk, Hybrid and Link access
Private VLAN	Direct Client ports in isolated /community VLAN to promiscuous port in primary VLAN
IEEE 802.1 QinQ	Double Tag for Private VLAN Access
Class of Service	IEEE 802.1p class of service, 8 priority queues/port
Traffic Prioritize	Supports 8 physical queues with weighted fair queuing (WRR) or Strict Priority Schemer, which follows IEEE 802.1p CoS tag ID and IPv4 Type of Service/Differ information to prioritize the traffic of your industrial network
IGMP Snooping	IGMP Snooping v1/v2c/v3 for multicast filtering and IGMP Query mode, also support unknown multicast forwarding policies- Drop, Flooding and Forward to route port
Rate Control	Ingress/Egress filtering for Broadcast, Multicast, Unknown DA or All packets
Port Mirroring	On-line traffic monitoring on multiple selected target ports
Port Security	Only permit the Link partner which with predefined MAC address to access the Ethernet interface
DHCP	DHCP Client/Server with IP & MAC address binding, DHCP Relay Agent function and DHCP Server with Static port based IP assigned function
IEEE 802.1x	Port Based Network Access Control with EAPoL to permit or Deny interface access with Remote RADIUS Server authentication
Cyber Security ^{*Note-2}	The Cyber Security function includes- DHCP Snooping protection, Dynamic ARP inspect protection, IP Source Guard (IPSG), Distribute Denial-of-Service (DDoS), IEEE 802.1x MAB for non-IEEE 802.1x compliant device.
Industrial Protocol	Modbus/TCP, Ethernet/IP
Network Redundancy	
Multiple Super Ring (MSR™)	New generation Korenix Ring Redundancy Technology, Includes Rapid Super Ring, Rapid Dual Homing, TrunkRing™, MultiRing™, Super Chain™ and backward compatible with legacy Super Ring™
Rapid Dual Homing (RDH™)	Multiple uplink paths to one or multiple upper Switch, up to 256 Groups RDH Peer protection
TrunkRing™	Integrate port aggregate function in ring path to get higher throughput ring architecture

MultiRing™	Couple or multiple up to 10 Rapid Super Rings in one device, JetNet 5020G supports up to 8 100M rings and 2 Gigabit rings
Super Chain	It is new ring technology with flexible and scalability, compatibility, and easy configurable. The ring includes 2 types of node Switch – Border Switch and Member Switch
Rapid Spanning Tree	IEEE 802.1D-2004 Rapid Spanning Tree Protocol. Compatible with Legacy Spanning Tree and IEEE 802.1w
Multiple Spanning Tree	IEEE 802.1s Multiple Spanning Tree, each MSTP instance can include one or more VLANs, and also supports multiple RSTP deployed in a VLAN or multiple VLANs
ITU-T G.8032 *Note-1	Support ITU-T G.8032 ERPS V1 single ring topology, and ERPS v2 multiple rings with ladder topology.
Loop Protection	The Loop Protection prevents any network looping caused by RSTP and MSR ring topology change
Interface	
Enclosure Port	10/100Base-TX Fast Ethernet: 16 x RJ-45 10/100Mbps, Auto MDI/MDI-X, Auto Negotiation 1000Base-T Gigabit Ethernet: 4 x RJ-45 100Mbps/1000Mbps, Auto MDI/MDI-X, Auto Negotiation SFP Fiber: 4 x SFP combo with RJ-45 with hot-swappable, and support digital diagnostic monitoring (DDM) function for fiber communicates quality management. The SFP Interface supports 100Mbps, 1000Mbps Fiber Transceiver with Auto-Recognize function RS-232 Console: RJ-45 (8P8C), Baud Rate: 9600, N,8,1 Power Connector: 4-Pin Removable Terminal Block DI/DO Connector: 4-Pin Removable Terminal Block
Cable	100Base-TX: 4-Pair UTP/STP Cat.5 Cable (Maximum 100Meters) 1000Base-T: 4-Pair UTP/STP Cat.5 Cable (Maximum 100Meters) Fiber: Refers to SFP Fiber Transceiver Specification
Diagnostics LED	10/100Mbps Port: Link/Active (Green on / Blinking), Full Duplex (Amber on) 1000Mbps Port: Link/Active (Green on/ Blinking), Speed (1000Mbps link Amber on, 10/100Mbps link Amber off) Pwr: Power Ready (Green On) Sys: System Ready (Green On), System on booting/update (Green Blinking) DI/DO: Digital Input (RED On), Dry Relay Active (RED On) R.S.: Green on (Ring normal)/Blinking (wrong ring port connective), Amber on (Ring abnormal) / Blinking (device's ring port failed)
Power Requirement	
System Power	Redundant Power Input with polarity reverse protection Typical Input Voltage: DC 24V, 9.6-60V variation
Power Consumption	10Watts/DC12V, 11Watts / DC24V, 14Watts/DC48V, 16Watts/DC60V
Mechanical	
Installation	EN50022 DIN Rail Mounting
Enclosure Material	Steel Metal with Aluminum
Ingress Protection	IP-30
Dimension (mm)	160 (H) x 108 (W) x 127 (D) without DIN Rail Clip 160 (H) x 108 (W) x 136 (D) with DIN Rail Clip
Environmental	
Operating Temperature	-40°C~75°C
Operating Humidity	0%-90%, Non-Condensing
Storage Temperature	-40°C~80°C
Hi-Pot Insulation	AC 1.2KV for Ethernet Interface to Power, Power to Chassis Ground, Ethernet Interface to Chassis Ground
Approvals	
EMC	EMI: IEC/EN61000-6-2, EN55022 FCC Class A, CE Radiation, Conduction EMS: IEC/EN61000-6-4 IEC61000-4-2, IEC61000-4-3, IEC61000-4-4, IEC61000-4-5, IEC61000-4-6, IEC61000-4-8 IEC61000-4-9
Vibration	IEC 60068-2-6 : 10-150Hz,20m/S ² , 20 Sweeps/Axis

Shock	IEC 60068-2-27: 50gn,18ms,Half-Sine wave
Free Fall	IEC 60068-2-32: 1 corner, 3 line, 6faces
Warranty	5 Years

- * Note-1: ITU-T ERPS V2 (By Request)
- * Note-2: Cyber Security (By Request)

Dimension (Unit = mm)

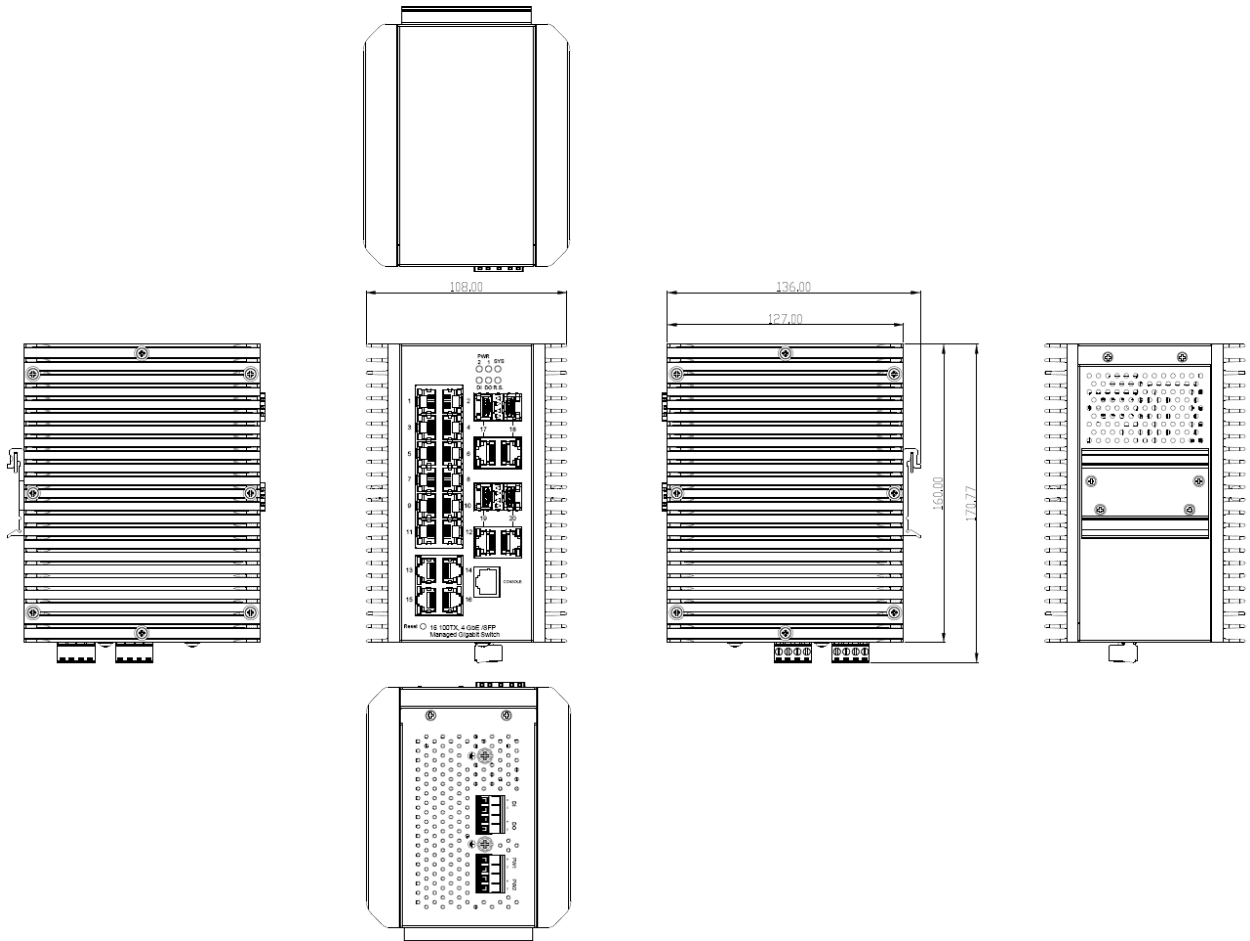

Ordering Information

- JeNet 5020G Industrial 16-port Fast Ethernet plus 4-port Gigabit Managed Switch, DC 9.6-60V input, -40~75°C

Includes:

- ▶ JetNet 5020G with DIN Rail Clip x 1
- ▶ Quick Installation Guide x 1
- ▶ Serial Console Cable x 1

Optional Accessories

Mounting Kit

MTK-W-143 Mounting Kit, Wall-mount plate, 143x38mm

MTK-RD-130 Mounting Kit, Robust DIN rail adapter, 130x52mm